

TK  
146  
.P88  
1901

PRACTICAL  
ELECTRICITY

PUBLISHED BY  
CLEVELAND ARMATURE WORKS.



Class TK 746

Book P 22

Copyright N<sup>o</sup> 1901

**COPYRIGHT DEPOSIT.**











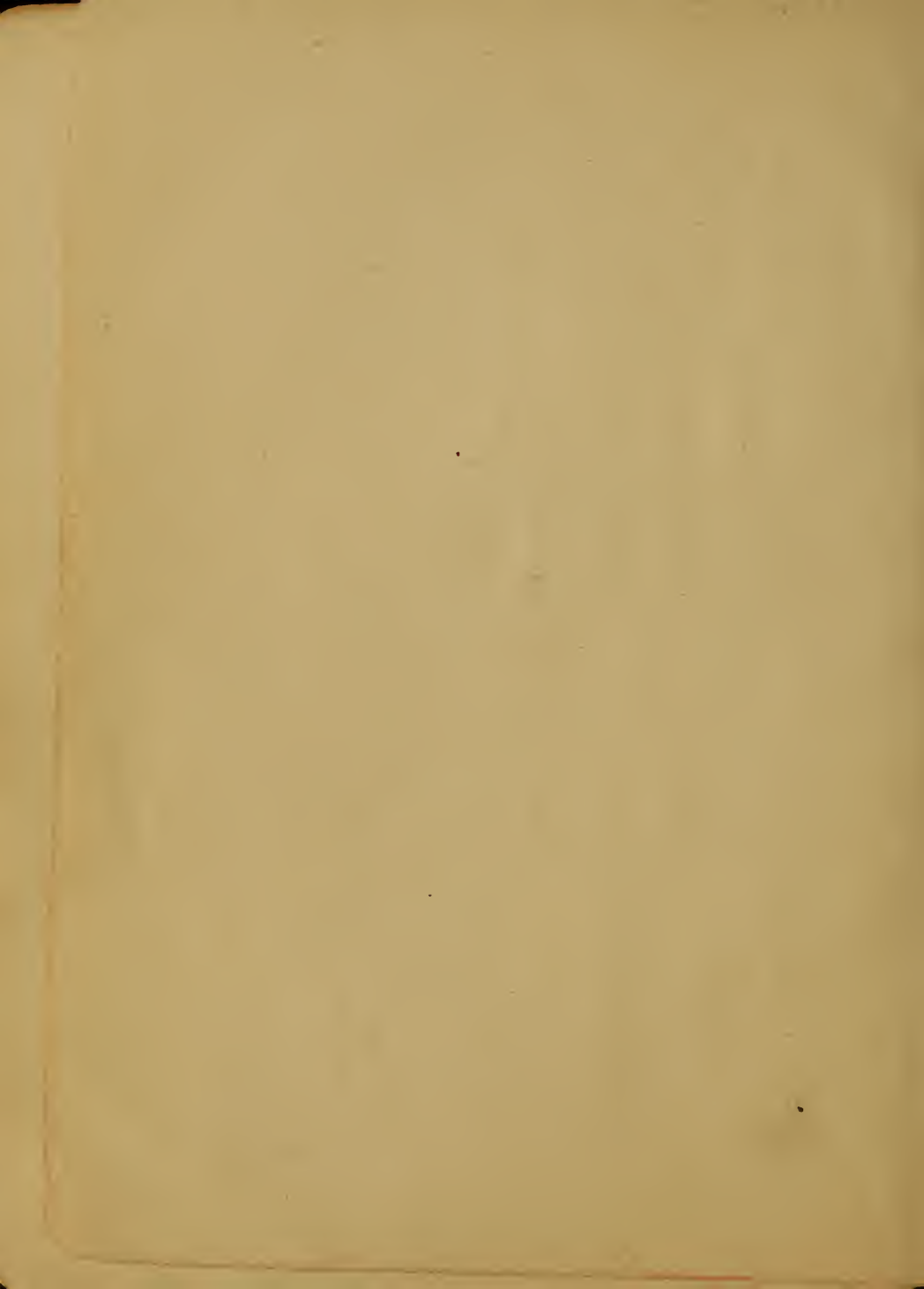



PRACTICAL  
ELECTRICITY



WITH  
QUESTIONS AND ANSWERS

THIRD EDITION

COPYRIGHTED

TK14  
P85  
1901

THE LIBRARY OF  
CONGRESS.  
TWO COPIES RECEIVED  
AUG. 17 1901  
COPYRIGHT ENTRY  
*Aug. 17. 1901*  
CLASS *a*XXc. No.  
*15130*  
COPY B.



2-1074

## INTRODUCTORY.

In March, 1896, The Armature Winder made its first appearance, its attractive feature being the commencement of a series of lectures on designing dynamos and motors, these lectures being written from daily shop practice, and made comprehensible by questions and their subsequent answers. As each paper with its lecture made its appearance, the interest manifested by readers became more pronounced, until we were flooded with inquiries for numbers which the various readers had missed. As we had only reserved a very few papers of each issue, our ability to supply the back numbers was limited. We consequently decided to print the lectures in book form, and so notified our readers of this decision, with the result that orders for the book came in, in quantities which were beyond anything we had anticipated. This evidence of the popularity of our efforts encouraged us in compiling a work much more extensive and valuable than had at first been our intention. In order to accomplish this, we felt the necessity of associating with us a man of greater technical knowledge than we ourselves possessed, so that the work might be thoroughly criticised and enlarged. We selected Mr. John C. Lincoln, an electrical engineer of national reputation, who has contributed articles to this book covering matters of great interest, and, so far as we have been able to learn, ideas never before appearing in print.

### CLEVELAND ARMATURE WORKS.

Cleveland, Ohio, July 1, 1901.

JAMES L. MAULDIN } PROPS.  
ALVIN A. PIFER }

## PREFACE.

This book was written especially to assist those who have some practical knowledge of electricity and who wish to learn more of the way in which wiring is calculated and of the simpler and more important parts of dynamo electric machine design. Some of the methods used and explanations advanced in the book are, so far as the writers know, entirely new, and it has all been written with the idea of illustrating the subject and making it as simple and as easy of comprehension as possible. The only way to obtain a working knowledge of the subject is by careful study. The book has been arranged so that those who are willing to devote some effort to the work can get a clear conception of the more important ideas and laws that underlie the subject. One who studies the text and answers the questions at the end of each chapter should be able to calculate a wiring job for lights or power; to calculate the proper size and amount of wire for a dynamo when he has the dimensions of the machine; to calculate the size and winding for a magnet to give a required pull, etc.

The table of contents shows the scope of the work.

The questions which follow each chapter, in connection with the answers, will bring out the more important points treated in each chapter. It is believed that a careful study of the text and the working of the examples will serve to throw a great deal of light upon a subject in which a great many people are interested. The dictionary in connection with this work is a valuable feature.

Houston's Electrical dictionary was largely used in the preparation of same.

CLEVELAND ARMATURE WORKS.

July 1, 1901.

CLEVELAND, OHIO.

## TABLE OF CONTENTS.

---

CHAPTER I.	Wiring.
“ II.	Electric Batteries. Electro Plating.
“ III.	Magnetism.
“ IV.	The Magnetic Circuit.
“ V.	Magnetic Traction.
“ VI.	Magnetic Leakage.
“ VII.	Energy in Electric Circuits.
“ VIII.	Calculation of Size of Wire for Magnetizing Coils.
“ IX.	Calculation of E. M. F.'s in Electric Machines.
“ X.	Counter E. M. F.
“ XI.	Hysteresis and Eddy Currents.
“ XII.	Armature Reaction.
“ XIII.	Sparking.
“ XIV.	Winding of Dynamos and Motors.
“ XV.	Proper Method of Connecting Dynamos and Motors. Self Excitation.
“ XVI.	Diseases of Dynamos and Motors, their Symptoms and how to cure them.
“ XVII.	Are and Incandescent Lamps.
“ XVIII.	Measuring Instruments.
“ XIX.	Alternating Current.

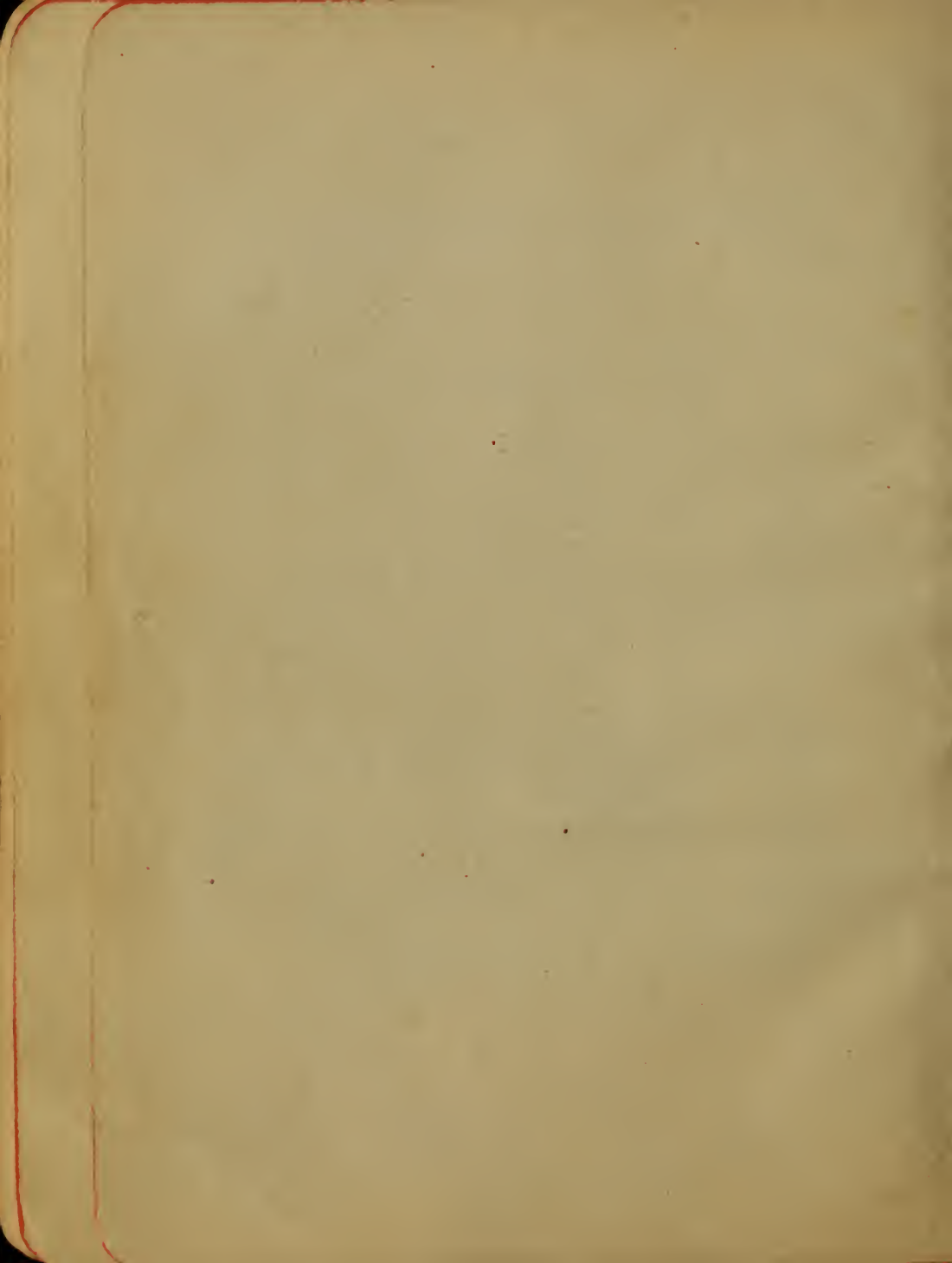

## CHAPTER I.

### WIRING.

1. It is very commonly said that nothing is known of electricity. This is both true and false. We do not know what electricity is nor anything of its ultimate nature, but we do know a great deal about the laws which govern the action of electricity.

For all ordinary purposes the action of electricity is very closely analogous to that of water. From the study of the principles which govern the flow and action of water a very great deal can be learned concerning the principles and laws governing the action of electricity.

In this analogy the water represents electricity. When water flows from a higher to a lower level, it is capable of doing work by driving some kind of a water wheel. The greater the height through which the water falls, the greater the amount of work it can do. The same thing is true of electricity. The greater the difference in electrical level, or difference of potential, or the greater the voltage, the greater the amount of electrical work the electricity can do. The unit of difference of electrical level is the volt, and we may say that the volt corresponds to one foot of "head" in a system for developing power by water. The amount of power that can be developed from a water fall depends on two things; first, the fall in feet or the head, and second, the size of the stream. At Niagara Falls the power that can be developed is practically infinite, not because the height of the fall is so great, but because the size of the stream is so great. Any water fall is capable of developing power, depending on the size of the stream. The unit of flow may

be taken as one gallon per second. The corresponding quantity in electricity is called current. The unit of current is called the ampere. The ampere then corresponds to the one gallon per second in a flow of water.

The amount of water that can flow from a higher to a lower level depends on the size of the pipe line through which the water is led. Imagine a large pond of water twenty-five feet above the sea. The amount of water that will flow from the pond through a 4-inch pipe is very much greater than what will flow through a  $\frac{1}{2}$ -inch pipe. Again if there are two pipes of the same size leading from the pond to the sea and one is twice as long as the other, about twice as much water will flow through the short pipe as through the long one. The friction of the water is greater in the long pipe, or the resistance to the flow is greater, and so less water flows.

There is no convenient unit for the resistance of a pipe to the flow of water, but the unit of resistance of a wire to carrying a current is well defined and is called the ohm.



Figure 1

Resistance offered to flow of water through a long crooked pipe.  
Discharge in gallons per minute corresponding to amperes.



The resistance offered by the long, small, crooked pipe to the flow of the water corresponds to the resistance offered by a wire to the flow of the electrical current. An inspection of Fig. 1 will show that the flow depends on the head. If, instead of having a head of 25 feet, it was increased to 50 feet, the amount of water discharged would be doubled, so that the flow depends on the head or pressure. If on the other hand the discharge pipe was made larger, or shorter, even with 25 feet head, twice as much water could be made to escape, so that the flow or current is inversely proportioned to the resistance.

Putting this in the form of an equation we have:

Discharge or current equals head or pressure divided by resistance or friction. In a circuit carrying electricity the same thing is true and we have: Electrical discharge or current equals electrical head or pressure, divided by electrical friction or resistance. Since the unit of electrical current is the ampere, and the unit of electrical pressure is the volt, and the unit of electrical resistance is the ohm, we have: Amperes equal volts divided by ohms, or putting it in the form of a fraction we have:

$$\text{Amperes equals } \frac{\text{volts}}{\text{ohms}}$$

This relation is known as Ohm's law and is one of the most important that we shall consider. Since the electrical pressure is what causes the movement of the electrical current, it is called electro-motive force, and as this term is very long it is abbreviated to E. M. F. Since the amperes measure the amount of flow of electricity, such flow is

called current, and this is abbreviated to C. Resistance is abbreviated to R., and we have our Ohms law

$$C \text{ equals } \frac{E. M. F.}{R} \quad (1); \text{ or } C \text{ equals } \frac{E}{R}$$

when E. is used in place of E. M. F.

By the way in which Ohms law was deduced it is plain to see that it is only one form of a general and universal law.

Ohms law is the statement for electrical quantities of the general law that the result produced is proportional to the effort expended, and inversely proportional to the resistance to be overcome.

To get a general idea of these units we may say that a single cell of storage battery has a voltage of two volts. One hundred and ten volts is the electrical pressure usually employed for lighting incandescent lamps. Two hundred and twenty volts is very frequently used as the E. M. F. for driving motors. Five hundred volts is universally used on street railroads to propel street cars. An ordinary gravity battery, such as is usually employed for telegraphic work, has an E. M. F. of one volt. Dynamos for electrotyping usually employ two or three volts. Dynamos for electroplating from five to ten volts.

The current taken by an incandescent lamp is about  $\frac{1}{2}$  ampere. The current required by a street arc lamp is from ten to six amperes, depending on the brilliancy of the light. The current used in a land telegraph wire is .003 to .005 amperes. The resistance of 1,000 feet of copper wire one-tenth of an inch in diameter is one ohm. Ten feet of German silver wire the size of the lead in a pencil has a resistance of one ohm. The resist-

ance of a mile of the heavy feed wire used in propelling street cars is about one-tenth of an ohm.

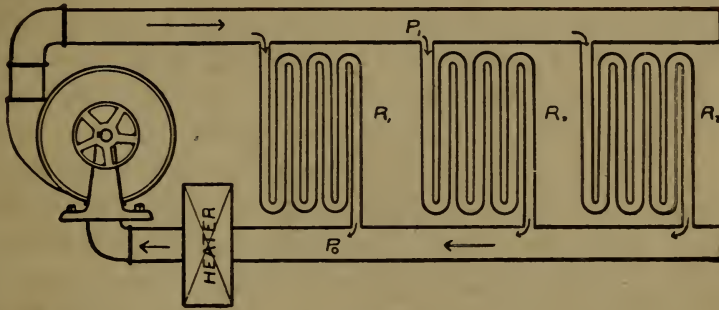

Figure 2

System for distributing hot water at constant pressure.

Suppose Fig. 2 to be part of the heating system of a building. The pump takes in the water from the low pressure pipe, and after passing through a heater it is forced out into the high pressure pipe to the radiators over the building. If the pipes P1 and P0 are large enough there will be the same pressure practically at all parts of the pipe, and each radiator R1, R2 and R3 will be exposed to the same pressure and receive the same amount of water provided they are similar. If, however, the pipes P1 and P0 are small, some of the pressure on the water in the pipe P1 will be lost in overcoming the friction of the pipe, so that radiator R3 farthest away from the pump would not get the same amount of pressure as Radiator R1 nearest the pump. There would be a similar loss of pressure in pipe P0. If the pump produces a pressure of twenty pounds per square inch, and the friction and resistance of the leading pipe P1 is great enough to cause the pressure to fall to 19 pounds at the nearest radiator R1, and causes it to fall to 18 pounds at R3, the

loss of pressure will be two pounds at R3 in the pipe P0, and two pounds in the pipe P1, if both P1 and P0 are of the same size. The loss will be one pound at R1 in each pipe.

Under these circumstances the pressure driving water through R1 is 18 pounds and through R3 is 16 pounds, instead of 20 pounds as produced by the pump. Such a system for distributing water is closely analogous to a constant potential or constant electrical pressure system for distributing electricity. The pump takes the water from one main pipe and raises the pressure and delivers it to the other pipe. The radiators between these pipes receive the water at practically constant pressure. The total stream in the main pipe is the sum of the individual currents in the radiators. The loss of head or pressure in the main pipes is greater as the flow of water is increased, and, if the radiators require practically constant pressure to work properly, soon reaches a limit. In each of these four respects such a water system is perfectly analogous to a constant potential lighting system. The pump corresponds to the dynamo in Fig. 3, which takes the electricity from one wire and raises its pressure so that it is 110 volts higher at one side of the dynamo than at the other.

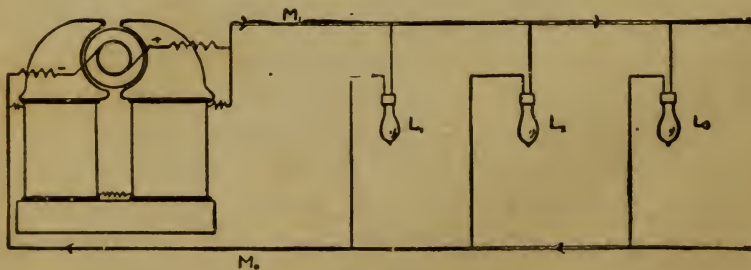

Figure 3  
System for distributing electricity at constant pressure.

The electricity is carried along the main wires M1 and M0, which correspond to the two pipes P1 and P0 in Fig. 2, to the incandescent lamps L1, L2, L3. It is evident that there is some loss of pressure in carrying the current along the main wires M0 and M1 from the dynamos to the lamps, and that this loss of pressure depends on the amount of current or upon the number of lamps in use.

The lamp L3 will get in any case some less pressure than the lamp L1, and when this difference becomes great enough so that L3 burns perceptibly dimmer than L1, the main lines M1 and M0 are carrying more current than they properly can. In practice the number of radiators in such a heating system as shown in Fig. 2 would not probably be much over 100, and usually very much less, while for the electric system the number of lamps on the dynamo will be from five to ten times as great.

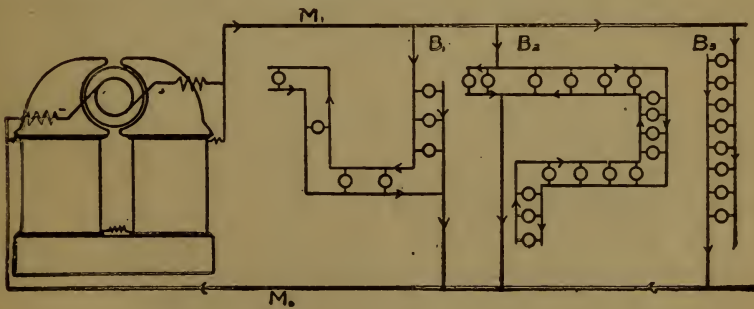

Figure 4  
Typical constant potential system.

Fig. 4 shows the dynamo taking current from the main M0 and delivering it at 110 volts higher pressure to the main M1. Part of it leaves the main M1 for the branch B1 and flows through the seven lamps to the other main M0. The

voltage is lost in overcoming the resistance of the lamps. The resistance of the lamps constitutes from 90 to 98 per cent. of the resistance of the circuit. A second part leaves the main at B2 and passes into the wires of this branch through the 17 lamps shown. The rest of the current passes to B3 and through the 8 lamps in that circuit. There will, of course, be some loss of pressure or "drop" in the branch circuits.

The calculation required in wiring is needed to find out how large to make the main wires M0 and M1 and how large the wire on the branch circuits should be. The whole system should be so designed that there should be a difference of only a volt or two between the various lamps on the circuit. The point to be aimed at is even or constant voltage for the lamps.

We will take up three different forms of Ohm's law that will be convenient for use in calculating wiring problems.

We have seen that C equals  $\frac{E. M. F.}{R}$ , or, put into words,

amperes equal volts divided by ohms.

The two other forms of this most important equation are volts equals amperes multiplied by ohms; or

E. M. F. equals C multiplied by R (2); and third, ohms

equal volts divided by amperes; or, R equals  $\frac{E. M. F.}{C}$  (3).

These three equations should be carefully studied and memorized. For our work in wiring, the second is the most

important. Equation (2) means that the loss in volts in any part of the circuit depends on the amount of current the wire is carrying, and also on the resistance of the wire. If the amount of current carried is doubled, the volts lost are doubled; and if a new wire is used of twice the resistance, the loss of volts is doubled, and in general the volts lost or the "drop" is equal to the amperes the wire is carrying multiplied by the ohms of resistance of the wire carrying the current. Suppose there were 100 lamps on the three circuits shown in Fig. 4 and that they were very close together, so that they all received about the same E. M. F. from the mains M1 and M0, but that the dynamo was about 500 feet from the lamps, near an engine. In such a case the principal loss of pressure would be in the mains carrying current between the dynamo and lamps. If we use No. 6 wire, which is .162 inches in diameter, there would be a resistance of .395 ohms in the mains, for there are 1,000 feet in the two mains, and the table No. 1 shows this. Each lamp requires  $\frac{1}{2}$  ampere, so that 100 lamps will require 50 amperes.

By formula 2 we have volts lost in leads or mains equal amperes multiplied by ohms, or drop, equals 50 multiplied by .395 equals 19.75 volts. In this case, if the lamps were to be supplied with 110 volts, the dynamo would have to produce 110 volts plus 19.75 volts, or 129.75 volts. Circuits of this sort are frequent, and if carefully operated such a great loss as 20 volts in the mains may be allowed. The ordinary case, however, is one in which the lamps are about equally distributed between the dynamo and the end of the circuit. In such a case a drop of 20 volts in the mains would not be permissible, for then the lamps near the dynamo would get 130 volts and those at the end of the

circuit would get 110 volts. This is altogether too much variation. The greatest variation that should ever be allowed is 8 volts, and all well-regulated plants do not have more than two. The reason that it is best to have the variation a minimum is that the incandescent lamps have a much longer life if the voltage is constant than if it is not. If a lamp has a life of 800 hours at 110 volts, it will not burn more than 200 hours at 115 volts, and if it is burned at 105 volts it will not give more than 2-3 of its rated light. The drop usually allowed in mains for a building does not exceed 3 per cent., and in the best plants is not over 2 per cent.

Table 1 gives the properties of copper wire of all the American or B. & S. (Brown & Sharpe) gauge sizes.



**TABLE 1.**  
**PROPERTIES OF PURE COPPER WIRE.**

Brown & Sharpe Gauge	AT 75 DEGREES FAHRENHEIT				R. Ohms per 1000 Feet	Amperes to Fuse Copper Wire 5 in. long with terminals weighing 2 oz. each.
	R. Ohms per 1000 Feet	Ohms per Mile	Feet per Ohm	Ohms per Lb.	150°	
	0000	.04906	.25903	20383.	.000076736	
000	.06186	.32664	16165.	.00012039	.07160	
00	.07801	.41187	12820.	.00019423	.09028	
0	.09831	.51909	10409.	.00030772	.1161	
1	.12404	.65490	8062.3	.00048994	.1435	
2	.15640	.82582	6393.7	.00078045	.1810	
3	.19723	1.0414	5070.2	.0012406	.2283	
4	.24869	1.3131	4021.0	.0019721	.2879	
5	.31361	1.6558	3188.7	.0031361	.3630	
6	.39546	2.0881	2528.7	.0049868	.4577	
7	.49871	2.6331	2005.2	.0079294	.5771	
8	.62881	3.3201	1590.3	.012608	.7278	
9	.79281	4.1860	1261.3	.020042	.9175	
10	1.	5.2800	1000.0	.031380	1.157	
11	1.2607	6.6568	793.18	.050682	1.459	
12	1.5898	8.3940	629.02	.080585	1.840	
13	2.0047	10.585	498.83	.12841	2.320	
14	2.5908	13.680	385.97	.20880	2.998	
15	3.1150	16.477	321.02	.31658	3.606	
16	4.0191	21.221	248.81	.51501	4.651	
17	5.0683	26.761	197.30	.81900	5.867	103.0
18	6.3911	33.745	156.47	1.3024	7.398	84.0
19	8.2889	43.765	120.64	2.1904	9.594	66.0
20	10.163	53.658	98.401	3.2926	11.76	56.3
21	12.815	67.660	78.037	5.2355	14.83	46.8
22	16.152	85.283	61.911	8.3208	18.70	39.3
23	20.377	107.59	49.087	13.238	23.59	33.5
24	25.695	135.67	38.918	21.050	29.73	27.4
25	32.400	171.07	30.864	33.466	37.50	24.4
26	40.868	215.79	24.469	53.235	47.30	19.6
27	51.519	272.02	19.410	84.644	59.64	17.0
28	64.966	343.02	15.393	134.56	75.20	14.4
29	81.921	432.54	12.207	213.96	94.82	11.8
30	103.30	545.39	9.6812	340.25	119.5	10.0
31	127.27	671.99	7.8573	528.45	147.3	8.6
32	164.26	867.27	6.0880	860.33	190.1	7.5
33	207.08	1093.4	4.8290	1367.3	239.6	6.3
34	261.23	1379.3	3.8281	2175.5	302.3	5.5
35	329.35	1738.9	3.0363	3458.5	381.3	4.7
36	415.24	2192.5	2.4082	5497.4	480.7	4.3
37	523.76	2765.5	1.9093	8742.1	606.1	4.0
38	660.37	3486.7	1.5143	13772.	764.3	3.7
39	832.48	4395.5	1.2012	21896.	963.6	3.6
40	1049.7	5542.1	.9527	34823.	1215.	3.0

TABLE 1 — Continued

Brown & Sharpe Gauge	Diameter in Mils	Circular Mils (d <sup>2</sup> ) — Mils (.001 In.)	Square Mils (d <sup>2</sup> x .7854)	Lbs. per 1000 Feet	Lbs. per Mile	Feet per Lb.	WEIGHT INSULATED WIRE.			
							Single Covered		Double Covered	
							Lbs. per 1000 ft.	Feet per Lb.	Lbs. per 1000 ft.	Feet per Lb.
0000	460.000	211600.00	166190.	639.33	3375.7	1.56				
000	409.640	167805.00	131790.	507.01	2677.0	1.97				
00	364.800	133079.40	104520.	402.09	2123.0	2.49				
0	324.950	105592.50	82932.	319.04	1684.5	3.13				
1	289.300	83694.20	65733.	252.88	1335.2	3.95				
2	257.630	66373.00	52130.	200.54	1058.8	4.99				
3	229.420	52634.00	41339.	159.03	839.68	6.29				
4	204.310	41742.00	32784.	126.12	655.91	7.93				
5	181.940	33102.00	25998.	100.01	528.05	10.00	128.0	7.811	128.37	7.79
6	162.020	26250.50	20617.	79.32	418.81	12.61	101.65	9.837	101.99	9.804
							80.70	12.39	81.06	12.336
7	144.280	20316.00	16349.	62.90	332.11	15.90	64.06	15.61	64.48	15.58
8	128.490	16509.00	12966.	49.88	263.37	20.05	50.82	19.68	51.18	19.54
9	114.430	13594.00	10284.	39.56	208.88	25.28	40.32	24.80	40.69	24.57
10	101.890	10381.00	8153.2	31.37	165.63	31.38	31.99	31.26	32.35	30.91
11	90.742	8234.00	6467.0	24.88	137.37	40.20	25.40	39.36	25.72	38.87
12	80.806	6529.90	5128.6	19.73	104.18	50.69	20.18	49.55	20.45	48.90
13	71.961	5178.40	4067.1	15.65	82.632	63.91	16.04	62.34	16.26	61.49
14	64.084	4106.80	3146.9	12.41	65.525	80.59	12.75	78.43	12.92	77.35
15	57.058	3256.7	2557.7	9.84	51.956	101.63	10.13	98.74	10.29	97.13
15	50.820	2589.9	2028.6	7.81	41.237	128.14	8.052	124.19	8.200	121.95

17	45.257	2048.2	1608.6	6.19	32.683	161.59	6.400	156.25	6.540	152.90
18	40.308	1624.3	1275.7	4.91	25.925	203.76	5.090	196.46	5.222	191.49
19	35.390	1252.4	983.64	3.78	20.051	264.26	3.93	254.45	4.070	245.70
20	31.961	1021.5	802.28	3.09	16.315	324.00	3.216	310.91	3.333	300.03
21	28.462	810.10	636.25	2.45	12.936	408.56	2.562	390.32	2.67	374.53
22	25.347	642.70	504.78	1.94	10.243	515.15	2.04	490.20	2.135	468.38
23	22.571	509.45	400.12	1.54	8.1312	649.66	1.628	614.26	1.715	583.10
24	20.100	404.01	317.31	1.22	6.4416	819.21	1.303	767.47	1.382	723.58
25	17.900	320.40	251.64	.97	5.1216	1032.96	1.045	956.92	1.114	897.66
26	15.940	254.01	199.50	.77	4.0656	1302.61	.833	1200.47	.905	1104.97
27	14.195	201.50	158.26	.61	3.2208	1642.55	.664	1505.04	.722	1385.03
28	12.641	159.79	125.50	.48	2.5344	2071.22	.526	1901.13	.589	1697.77
29	11.257	126.72	99.526	.38	2.0064	2611.82	.420	2380.90	.485	2061.83
30	10.025	100.5	78.933	.30	1.5840	3293.97	.335	2985.13	.400	2500.
31	8.928	79.71	62.604	.24	1.2672	4152.22				
32	7.950	63.20	49.637	.19	1.0032	5236.66				
33	7.080	50.13	39.372	.15	.7920	6602.71				
34	6.304	39.74	31.212	.12	.6336	8328.30				
35	5.614	31.52	24.756	.10	.5280	10501.35				
36	5.000	25.00	19.635	.08	.4224	13238.83				
37	4.453	19.83	15.567	.06	.3168	16691.06				
38	3.965	15.72	12.347	.05	.2640	20854.65				
39	3.531	12.47	9.7939	.04	.2112	26302.23				
40	3.144	9.89	7.7676	.03	.1584	33175.94				

The above table is only approximate, due to the fact that different makers use different weights of insulation on the same size of wire. The table gives a fair average.

Consulting this table to see how the resistance of .395 was found for the two 500 feet leads or mains, look down the left hand column until we come to No. 6. The second column shows that the diameter of No. 6 wire is .162 mills, or 162-1000 of an inch. In the first section of the table we see that 1000 feet of No. 6 wire has a resistance of .395 ohms.

Fig. 5 shows the ordinary lighting circuit with the dynamo in the middle of the circuit and the lamps about equally distributed along the circuit.

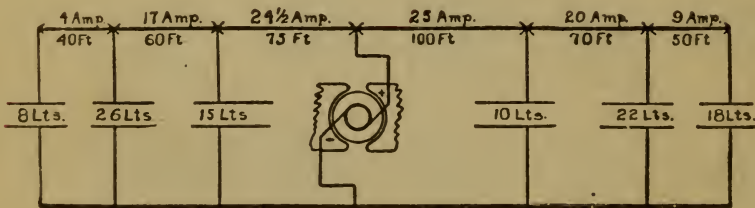

Figure 5  
Ordinary lighting circuit.

Theoretically at every branch the size of the mains should be reduced, but, as this is practically impossible, it is usual to carry the large wire far enough and make a reduction in size only once or twice. In Fig. 5 we will allow a loss of two volts in the leads. Taking the left hand side of the circuit, if we assume the full amount of  $24\frac{1}{2}$  amperes to be carried, 75 feet plus 60 feet, or 135 feet, we shall get a wire large enough and the drop will be less than the two volts rather than more. This will allow for some additional drop in the additional 40 feet for the last

circuit. We have then two volts equals  $24\frac{1}{2}$  multiplied by

ohms, or ohms equals  $\frac{2}{24\frac{1}{2}}$  equals .0816 ohms. We must

find a wire then that has a resistance of .0816 ohms in 270

feet. Such a wire will have a resistance of  $\frac{1000}{270}$  multi-

plied by .0816 for 1,000 feet, or .302 ohms per 1,000 feet.

Consulting the table, we find that No. 5 wire has a resistance of .313 per 1,000 feet, and we will select this as the size to be used. On the right hand side of the circuit we will select a wire large enough to give two volts drop if all the current is carried to the second branch circuit, or 2

equals 25 multiplied by R, or R equals  $\frac{2}{25}$  equals .08

ohms. As the length of the wire is 170 multiplied by 2

equals 340 feet, the resistance of 1,000 feet of this wire will

be  $\frac{1000}{340}$  multiplied by .08125, or .335 ohms.

340

Consulting the table we see that No. 4 wire has a resistance of .248 per 1,000 feet, and we will select this. For short branch wires it is best to use the table of the fire underwriters, which limits the amount of current a wire shall carry by the heating of the wire. Table II shows these values.

Currents allowed by fire underwriters in wires of various sizes:

TABLE II.

Table A.		Table B.	
Rubber Covered Wires.		Weatherproof Wires.	
B. & S. G.	Amperes.		Amperes.
18 .....	3 .....		5
16 .....	6 .....		8
14 .....	12 .....		16
12 .....	17 .....		23
10 .....	24 .....		32
8 .....	33 .....		40
6 .....	46 .....		65
5 .....	54 .....		77
4 .....	65 .....		92
3 .....	76 .....		110
2 .....	90 .....		131
1 .....	107 .....		156
0 .....	127 .....		185
00 .....	150 .....		220
000 .....	177 .....		262
0000 .....	210 .....		312

For small isolated plants 5 volts drop is usually allowed so that the sizes for the leads we have figured for 2 volts drop are plenty large enough for good results for such plants. The drop is often expressed in per cent. A 5 per cent. drop is 5 per cent. of 110 volts, or  $5\frac{1}{2}$  volts.



Figure 6  
Drop in branch circuit  
tapped at end.



Figure 7  
Drop in same circuit connected  
in center.

If possible, branch circuits should be tapped on to the mains at the center of the branch, in order to secure a more even voltage at the lamps.

If the branch wires in Figs. 6 and 7 are both of the same size, it is easy to see that the drop in the branch wire as connected in Fig. 6 is very much greater than in Fig. 7. In fact, the drop in Fig. 7 is only one-fourth of that in Fig. 6, for in Fig. 7 each branch carries half the current half the distance that it does in Fig. 6. Sometimes when from circumstances the drop in the branch circuits is bound to be very great, it is possible to connect them so that while there is a great deal of drop in each line all the lamps receive the same voltage.



Figure 8

Method of connecting lamps so as to get even voltage at lamps even with great drop in the line.

Fig. 8 shows such a connection. If the drop in each wire were five volts from one end to the other and the mains supplied 115 volts, each lamp would still get 110 volts. The great trouble with such schemes is that, although they work well when fully loaded, when partly loaded the voltage on the lamps that do burn is excessive and certain to shorten the life of the lamps. The only way to install a plant that will be perfectly satisfactory in the way of drop in the lines is to use wire large enough, so that when fully loaded the drop is small, then with light loads it will be still less.

## CALCULATION OF FEEDERS FOR STREET RAILWAY WORK.

In street railway wiring we have the peculiar case that only one side of the line is wire and the earth is used for the return.

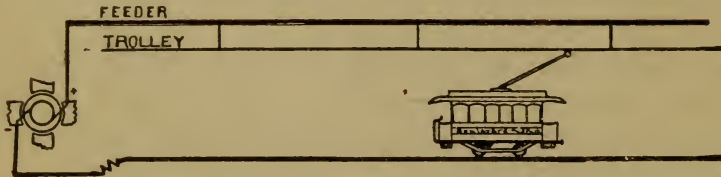

Figure 9  
Electric circuit of street car system.

The rails are electrically connected to each other by bonding, and also are connected to the dynamo at the power house. It is usual to connect the dynamo to the gas and water pipes in the city, so as to take the current that naturally flows in them. In a well-bonded track there is not much loss of voltage in the return or ground circuit, and all the loss is figured in the overhead wire. The trolley wire is usually No. 1 or No. 0, so as to give mechanical strength. The trolley wire is supplied from feeders, which are large wires running from the dynamos and connected to the trolley wires at various points. For the heaviest loads at least 10 per cent. loss or 50 volts is allowed in the feeder. How large should a feeder three miles long be to carry 300

amperes with 50 volts loss? Here we have  $\frac{50}{300}$  equals



ohms in feeder equals  $\frac{1}{6}$ . As there are three miles of feeder the resistance per mile will be  $\frac{1}{6}$  multiplied by  $\frac{1}{3}$  equals  $\frac{1}{18}$ , or .0555 ohms per mile. The table does

not give the size of a wire so large as this, but it will be ten times as large as one that has ten-eighths, or .555, ohms per mile, or a wire a little less than ten times as large as No. 0 wire, is what we want. This will be a wire of about 105600x10 circular mils, or about 1,000,000 circular mils, or about one inch in diameter. Such a wire is very expensive to put up, so that it would be cheaper to install four wires  $\frac{1}{2}$  inch in diameter, as these would have the same size and carrying capacity as the single large wire.

The calculations required in wiring are almost universally used in connection with constant potential circuits.

There are two ways in which electricity is distributed: First, constant potential; and second, constant current. In-

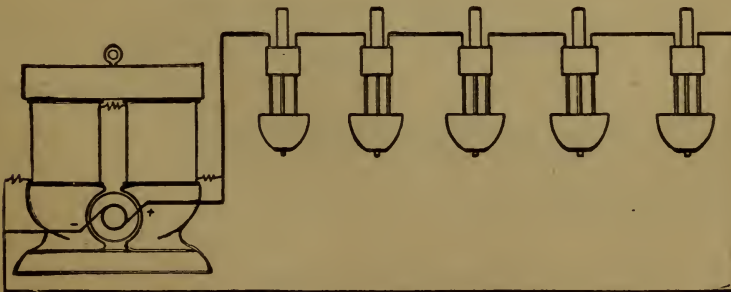

Figure 10  
Arc light circuit.

candescence lighting and a great deal of arc lighting, street railway systems and all important plants for the transmission of power are operated on the constant potential system. Most of the arc lights that are in use, especially the older ones, are operated under the series system. In the first case, each lamp or motor receives the full voltage of the system and only part of the current. In the second, each lamp receives the full current flowing in the system, but only part of the voltage. Each arc lamp in a series system takes from 50 to 55 volts.

Some of the latest arc dynamos will carry 125 or even 150 such lamps, which requires a pressure of nearly 8,000 volts. Such a voltage is very dangerous, and this is one reason why the series system is not in general use. A 2,000 candle power arc lamp requires 9 to 10 amperes, and a 1,200 candle power from 6 to 6½. No. 6 B. & S. is usually used for 2,000 candle power arc light lines and No. 8 for 1,200 candle power. A convenient rule by which to calculate the resistance of copper wire in the absence of a table is R equals 10.8 multiplied by length in feet divided by diameter in mils, or one-thousandth of an inch squared, or

$$R \text{ equals } \frac{10.8 \text{ multiplied by } L}{M^2}$$

in which L equals length in feet and M equals the diameter in mils.

## QUESTIONS ON WIRING.

1. What is known of the nature of electricity?
2. What is known of the laws governing its action?
3. What analogy may be used to illustrate the action of electricity?
4. In the analogy of the action of water and electricity, what corresponds to electric pressure? What to electric current? What to electric resistance?
5. What is the unit of electric pressure?
6. To what unit in hydraulic work does it correspond?
7. What is the unit of electric current?
8. What is the unit of electric resistance?
9. What is Ohms Law?
10. Is Ohms Law peculiar to electricity or does the same general law hold in other work? Give an example.
11. How many volts does an ordinary storage battery produce?
12. What pressure is usually employed for incandescent lamps?
13. How many amperes are used by an ordinary incandescent lamp? How many by an arc light?
14. What is the resistance of 1,000 feet of copper wire 1-10 inch in diameter?
15. Give an example different from that in the text of the loss of pressure with the transmission of fluids.

16. On what does the loss of pressure in a pipe carrying a fluid depend?

17. To what does the pump in a system for distributing fluids correspond in an electric system?

18. Give other points of analogy between the example you have selected and the electric system.

19. Upon what does the loss of pressure in a wire depend?

20. Draw a diagram of a constant potential electric system with four branch circuits and 38 lamps distributed among them.

21. What part of the whole resistance of a circuit should the lamps be?

22. What is "drop"?

23. What is the ideal condition as regards drop in wiring up an electrical plant?

24. Why is it not possible to realize the ideal condition?

25. What are calculations in wiring required for?

26. What are the three different statements or forms of Ohm's law?

27. Which is the most important in wiring problems?

28. Write out in your own words what equation (2) means.

29. How many volts are lost in a circuit carrying 120 amperes and having a resistance of 1-30 of an ohm?

30. What sized wire would be required for such a circuit if it were 400 feet long?

31. How many amperes are flowing in a wire of —  
ohm if there is a drop of two volts in it?

32. What is the resistance of a wire that has  $3\frac{1}{2}$  volts drop when carrying 45 amperes?

33. If a dynamo supplies current to its circuit at 114 volts and each main wire has a drop of three volts, what voltage is there on the lamps?

34. A certain station fed a number of lamps at a considerable distance. The drop was 55 volts, the resistance of the circuit was  $\frac{1}{220}$  of an ohm. How many amperes was the station carrying?

35. What drop is allowed in the mains of the best plants?

36. A dynamo in a basement is used to light a building. The wires are carried 100 feet before any branch circuits are taken off, and then one is taken off every 12 feet for 96 feet. What sized wire would be required to carry 400 amperes with a drop in the wires of three volts?

37. Why is it best to attach a branch circuit to the main in the middle?

38. A certain plant is used to light a building. It is desired to light another building 800 feet away and using 1,000 lamps. In order to save copper, 115 volt lamps are used in the first building and 100 volt lamps in the second building. At 15 cents per pound, how much less would the copper for the mains cost with 100 volt lamps in the second building than with 110 volt lamps?

39. What are the objections to such a scheme as outlined in question 38?

40. In branch circuits carrying a large number of lamps, what table should be employed to determine the size of the wire?

41. How many volts drop are usually allowed in the feed wires of street railway circuits?

42. How do the currents return from the street cars to the dynamo?

43. Why does such a return as is used in street railway work save copper?

44. How large a wire would be required to carry 500 amperes  $1\frac{1}{2}$  miles with a drop of 75 volts?

45. What would such a wire cost at  $.14\frac{1}{2}$  per pound?

46. If 125 volts drop were used, what current would this wire carry?

47. If 500 amperes were carried on a wire at 125 volts loss  $1\frac{1}{2}$  miles, how much would the wire cost at  $.14\frac{1}{2}$  per pound?

48. What size of trolley wire is usually employed in street railway work?

49. Sketch out a system of wiring for street railway circuit by which the voltage when near the power house is less than when at a distance from it.

50. In what two ways is electricity distributed?

51. For what is the series system used?

52. What is the characteristic feature of the constant potential system?

53. Of the series system?

54. What current is required for a 2,000 c. p. arc lamp?

55. What current is required for a 1,200 c. p. arc lamp?

56. What is a convenient rule for calculating the resistance of a copper wire in the absence of tables?

## CHAPTER II.

### ELECTRIC BATTERIES.

In the year 1786 Galvani was making some experiments with frogs' legs and had a number supported by the spinal cord from copper hoops attached to an iron railing. He noticed that when the muscles touched the railing that the frog's legs contracted spasmodically. This experiment led finally to the production of the electric battery.

Volta, in the year 1800, produced the so-called voltaic pile, which is one of the simpler forms of a battery. The easiest and most simple way to make a battery is to insert in a jar partially filled with acidulated water, or even brine, a strip of zinc and one of copper. Upon joining the zinc and copper outside the solution by a metallic conductor, a current of electricity will flow from the copper to the zinc through the conductor and from the zinc to the copper through the acid. The way in which the current flows through the acid is not thoroughly understood, but this flow is accompanied by the oxidation or slow burning of the zinc and by the evolution of hydrogen gas on the copper. The primary cause of the flow of the current is the combustion or oxidation of the zinc, and if the conditions are properly arranged the amount of current that flows is strictly proportional to the amount of zinc consumed.

The appearance of the hydrogen gas on the copper reduces the current which flows by covering it to a great extent with a thin layer or coating of hydrogen gas. The battery will deliver much more current when means are provided to prevent the formation of gas upon the copper.

TABLE III.

## ELECTRO-CHEMICAL SERIES OF THE ELEMENTS.

—	+
Oxygen	Caesium
Sulphur	Potassium
Nitrogen	Sodium
Flourine	Zinc
Chlorine	Iron
Bromine	Copper
Iodine	Silver
Phosphorus	Mercury
Carbon	Platinum
Antimony	Gold
Hydrogen	

The process of coating the copper with hydrogen gas is called polarization. The zinc plate is called the positive element, the copper plate is called the negative element. The binding post by which the current leaves the copper is called the positive pole, because the current flows from this binding post through the outside circuit to the negative pole on the zinc plate. Some metals may be used in place of the zinc as the positive element in the battery; among these the more important are potassium and sodium. Many metals may be used to take the place of copper, but the material most frequently employed is carbon.

A battery composed of zinc and carbon has a much higher electro-motive force than one in which the zinc and copper are used; in fact, the elements may be arranged in a series in which any one may be used as a positive element



in combination with any below it, and as a negative element when used in combination with any above it. Table No. 3 is such a list.

Zinc and copper in a solution of sulphuric acid give an electro-motive force of about one volt. Zinc and carbon give about two volts. Zinc and carbon with an alkaline solution, such as salamoniac or potash, give about one volt and one half. Various means are employed to prevent the hydrogen from appearing or adhering to the negative element. Some of these are mechanical, such as the use of very fine metallic powder, such as platinum sponge, which permits the bubbles of gas to escape when very small, or by the use of a stream of air bubbles which mechanically carries away the hydrogen from the surface of the negative element. The first method is used in the Smee battery, in which the negative element is a thin plate of silver on which has been deposited a coating of very finely divided metallic platinum called platinum sponge.

By all means the more important method for preventing the appearance of hydrogen on the negative element is the use of some chemical which consumes the hydrogen before it reaches the negative element. This is usually accomplished by inserting the negative element in a porous cup which is filled with a powerful acid or with some other material which burns up the hydrogen.

When the zinc of a battery is consumed it combines with oxygen from the solution in which it is placed, and for every atom of oxygen which chemically unites with the zinc two atoms of hydrogen are evolved, and these travel from the surface of the zinc through the solution in some way toward the negative plate. If somewhere between

the positive and negative plates a porous cup is placed, the hydrogen will pass through the pores of this cup on its way toward the negative plate.

If within the porous cup is placed a very powerful acid, the hydrogen is consumed or burned up as soon as it reaches this acid, and thus the polarization which would otherwise occur from the appearance of hydrogen gas on the negative plate is prevented.

Zinc is used as the positive element in almost every battery.

The reason why primary batteries are not used for the purpose of developing power is not that they could not be so used, but because the zinc and sulphuric acid which would be required to produce the power are so expensive as to be prohibitive. Efforts are being constantly made to produce a battery in which carbon may be used as the positive element. If such a battery could be commercially produced with an efficiency equal to the zinc battery, it would revolutionize the present methods of producing power and be one of the greatest inventions.

If a plate of carbon be immersed in fused nitrate of soda and an iron plate be used as the negative element, current will be obtained. There is a dispute as to the source of this current, some claiming that it is electro-chemical and others that it is produced by electro-thermal effects. In either case the battery has not been sufficiently effective to be practical.

A very powerful battery for experimental purposes (see Fig. 11) may be constructed by using a number of carbon brushes or plates fastened parallel to and close to each side

of the zinc plates and arranged so as to be plunged into a solution of sulphuric acid, water and bi-chromate of potash.

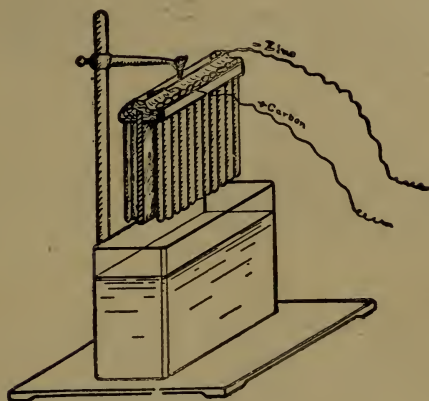

Figure 11  
Dip or plunge battery.

This solution may be made by adding to one quart of water one-half pint of commercial sulphuric acid and one-quarter pound of bi-chromate of potash.

The writer has obtained a current of 30 amperes from a single cell of this battery, six inches in diameter and six inches deep. It is necessary to provide means by which the plates may be raised from the solution as soon as the occasion for their use is past.

In order to get the best results from the use of the zinc plate when made of commercial zinc, it is necessary to amalgamate it or wet the surface with liquid mercury. This may be easily done by first mechanically cleaning the plate, next removing any grease by the use of potash or

soda, and third by immersing it for a few moments in an acid. The acid which is intended to be used as an electrolyte for the battery will answer. This will cause the zinc plate to present a perfectly clean surface, and the mercury will quickly spread all over it. This treatment prevents the acid from attacking the zinc when the outside circuit is not closed.

Below is a table giving the names of a number of the more prominent cells in use, and the voltage on an open circuit, the electrolyte used and the character of the plates.

TABLE IV.  
DATA OF COMMON BATTERIES.

Name of Cell.	E. M. F.	Plates.		Electrolyte.
Bunsen.....	1.95	Zinc	Carbon	{ Nitric and Sulphuric Acid
Groove.....	1.93	"	"	{ Nitric and Sulphuric Acid
Gravity.....	1.07	"	Copper	{ Copper Sulphate Zinc Sulphate
Leclanche.....	1.47	"	Carbon	Salamoniac
Dry Cell.....	1.50	"	"	Salamoniac Paste
Edison Lelande.....	.90	"	Copper Oxide	Caustic Potash
Lead Storage.....	2.00	Lead	Lead	Sulphuric Acid

It is a fact that with perfectly pure zinc and all conditions being perfect, the passage of a certain amount of current through a battery is invariably accompanied by the solution or consumption of a certain amount of zinc.

Conversely, if a current from an outside source be passed through a battery from the zinc through the

electrolite to the carbon, metallic zinc will be deposited from the solution, provided the battery has been used before the experiment is made.

In fact, the amount of electricity which passes through a properly arranged solution may be very accurately measured by the amount of metal which is deposited from the solution. An instrument arranged to measure current in this way is called a volta-meter.

Practical electricians will recall the old Edison meters, by which current was measured and sold to customers from the old Edison stations.

In this instrument the current was caused to pass from one plate of zinc through a solution of sulphate of zinc and out through a second plate of zinc. The passage of ten amperes for ten hours through this meter causes the solution of 4.33 ounces of zinc from the first plate by which the current enters the solution, and the deposit of an exactly equal amount from the solution upon the second plate. Every month these two plates were removed and weighed and the weight compared with what it was a month before. The amount of current that had passed was calculated from the change in weight. The plate by which the current enters the solution is called the anode, and the plate by which the current leaves the solution is called the cathode. It will be convenient to remember that the current always carries the metal with it from the anode into the solution and from the solution on to the cathode. In fact, it is easy to determine the direction in which a current is flowing by causing all or a part of the current to pass through a glass tumbler partly filled with a solution of sulphate of copper or blue vitriol, in

which are immersed a couple of nails, one connected with each side of the circuit which is to be tested. On one of the nails will appear bubbles of gas, while the other will be more or less rapidly covered with a layer of metallic copper. The current will flow from the first nail through the solution to the second nail.

A very great deal of attention is now being given to the chemical changes that are brought about by the action of electric current upon the various chemical compounds, and it is the writer's belief that the greatest advances in electrical knowledge during the next few years will be made along this line.

### ELECTRO-PLATING.

We have discussed above the principles upon which electro-plating depend.

The general scheme is to cover one metal with a thin layer of another metal by electro-chemical means. To do this a solution is prepared and in this solution are immersed a number of anodes, usually of nickel, silver, copper, gold or brass, with which it is desired to plate the second metal. In the same solution is immersed the metal to be plated.

A current is passed from the anode through the solution to the metal to be plated, or cathode. The action of the current is to decompose the solution and deposit the metal from the solution on the cathode, at the same time forming a portion of acid which in some way passes through the solution to the anode and there dissolves just as much of the anode into the solution as was deposited by the current out of the solution.

The amount of metal deposited upon the cathode depends upon the amount of current which flows and upon the time it flows or upon the ampere hours of current. If the amount of current is properly arranged, the metal will be deposited from the solution in an even adhesive layer. If too much current flows, the metal will not be deposited in such a firm layer and the corners will have a blackened appearance, when the work is said to be burned. The skill of the plater comes, first, in getting the work to be plated chemically clean; second, in arranging the solutions properly; third, in adjusting the amount of current to the solution and the amount of work. One kind of solution is used with zinc, another with nickel, another with silver, and another with copper.

Each solution requires special treatment, and to get good results, expert knowledge.

It is a peculiar fact that a mixture of metals, such as brass, may be used in plating, but that the voltage required with such a solution is two or three times higher than that required by copper or nickel.

Below will be found a table of the elements, giving their names, atomic weights, relative resistances by volume, relative resistance by weight and weight deposited by ten amperes in ten hours.

TABLE V.

## PROPERTIES OF METALS

	Specific Gravity	Relative Resistance of Wires 100 ft. long weighing 1 pound	Relative Resistance of Equal Volume	Atomic Weight	Pounds Deposited in ten hours by ten Amperes
Copper .....	8.94	1.00	1.06	63.4	.2636
Silver .....	10.5	1.113	1.00	108.	.8980
Gold .....	19.26	2.203	1.27	197.	.5460
Aluminum .....	2.56	.526	1.95	27.	.0569
Zinc.....	7.13	2.732	3.74	65.2	.2710
Platinum .....	21.5	13.62	6.02	197.	.4145
Iron .....	7.84	5.33	6.46	56.	.0776
Nickel ..	8.82	7.69	8.28	58.8	.1222
Tin .....	7.30	6.75	8.78	118.	.2453
Lead.....	11.4	15.55	13.05	207.	.4303
German Silver.....	8.5	12.16	13.92		
Antimony.....	6.72	16.69	23.60	122.	.1863
Manganese Steel.....	7.8	34.82	42.43		
Mercury.....	13.6	89.76	62.73	200	.3315
Bismuth.....	9.8	89.92	87.23	210.	.3492



## STORAGE BATTERIES.

When two plates of lead are immersed in a solution of sulphuric acid and a current is passed through the cell, there is a tendency to produce an oxide of lead on one plate and spongy or metallic lead on the other plate. If the plates are properly prepared and the current is sent through the battery repeatedly, first in one direction and then in the other, the cell will finally be completed or formed. This method of making a storage cell is called the Platite process.

In a completed storage battery, passing the current through the battery is called charging it, and the charging produces chemical changes on the plates, which will produce electric currents if the plates are connected by a wire outside the battery.

When current is flowing from the battery it is said to be discharging. The battery will continue to discharge until the chemical products formed by the charging current have been reduced to their original state. The advantages possessed by the storage battery over the primary battery are that there is no polarization and the resistance of the battery may be made very much lower than that of a primary battery.

As its name indicates, the storage battery is practically a device for absorbing energy from an electric circuit at one time and restoring it to the electric circuit at some subsequent time. The charging current in a good battery may vary between wide limits, but the best results will be obtained from a moderately small amount of charging current. The same thing is true of the amount of the current

during discharge. The best modern storage batteries used for horseless carriage work, where extreme lightness is essential, have a capacity of two ampere hours per battery for every pound of weight in the battery and a capacity of four watt hours per pound in the battery.

The two principal uses for storage batteries at the present time are for storing power in central stations during times of light load, so that it can deliver the power during the time of the heaviest load, and second, for furnishing electric current for motors for horseless carriages and electric launches. Storage batteries may also be used to great advantage near the end of a long line which has an intermittent load on it. The battery will absorb current during times of light load and deliver it during times of heavy load, thus making the current that comes over the line from the central station practically constant. The great objections to the storage battery are its cost and weight. So far, no one has succeeded in making a practical battery out of any other material than lead.

## QUESTIONS ON CHAPTER II.

### BATTERIES.

1. What two men were chiefly instrumental in the early development of the electric battery?

2. Describe a way in which a simple battery may be constructed.

3. In which way does the current from a battery flow in the outside circuit?

4. What is the real cause of the flow of current in a battery?

5. What is polarization?

6. What is the positive element in a battery? What is the negative element?

7. What is the positive pole of a battery?

8. What metals may be used to advantage in place of copper in a battery?

9. Consulting table No. 2, why is it that zinc and carbon produce a higher E. M. F. than zinc and copper?

10. What means are used to prevent hydrogen from appearing on the negative element?

11. Describe a chemical means for preventing hydrogen from appearing on a negative element?

12. Why are primary batteries not used to develop power?

13. Describe a battery in which carbon is used as a positive element.

14. How may a powerful battery for experimental purposes be made?

15. In order to get the best results from a zinc plate when used in a battery, how must it be treated?

16. What is the relation between the amount of zinc consumed in a battery and the amount of current it produces?

17. What is a voltameter?

18. Describe the Edison current recording meter.

19. What is an anode? What is a cathode?

20. Does a current of electricity carry a metal with it or against it?

21. How may the direction of a current be determined by chemical means?

### ELECTRO-PLATING.

1. What is accomplished by electro-plating?

2. Describe the process of electro-plating.

3. On what does the amount of metal deposited depend?

4. What is the effect of having too much current in electro-plating?
5. Is it possible to plate with an alloy, such as brass? If so, how?

### STORAGE BATTERIES.

1. What is a storage battery?
2. Describe the process of charge and discharge.
3. What advantages does the storage battery possess over ordinary batteries?
4. For what are storage batteries used?

## CHAPTER III.

### MAGNETISM.

If a hard piece of steel be brought into contact with a magnet it will become magnetized and will retain more or less of the magnetism. If steel of the proper kind and which has had the proper treatment is chosen, the magnetism will be constant, almost absolutely constant. Tungsten steel, artificially aged, is used for volt meters and measuring instruments in which the accuracy of the instrument depends on the constancy of the magnetism of the steel, and the steel meets the requirements. If a magnet is supported so as to be free to turn in a horizontal plane, it will set itself north and south, as is seen in the mariner's compass.

The pole that turns toward the north is called the north or N. pole and the other the south or S. pole. It is a fact that like poles repel each other and unlike poles attract each other.

The earth on which we live is a great magnet, and this has its S. magnetic pole at or near the north geographical pole, for if by definition a N. pole is one that points to the north and unlike poles attract each other, the N. pole of the compass must point toward the S. magnetic pole of the earth.

A magnet is surrounded by what is called a field of force.

What are called lines of force are supposed to spring from the iron or steel at the north pole, pass through the air to the south pole, enter the iron and pass through it to the north pole. The lines of force are said to flow in the direction indicated. This should be carefully kept in mind, as it will be used a great deal later.

A line of force is always a closed curve, and if any one travels along the whole of a line of force one will always come to the starting point. A line of force is the direction of the magnetic force at any point.

The lines of force from the earth are flowing in the air from the south to the north. Near the equator the magnetic force acting on a horizontal compass needle is greater than in other parts of the earth.

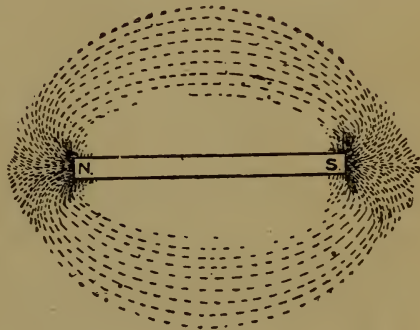

Figure 13  
Bar magnet and field of force.

The earth as a magnet acts on a horizontal compass in the United States with a force corresponding to from one to two magnetic lines per square inch.

If a bar magnet be placed under a piece of pasteboard or glass, and iron filings be sprinkled over the pasteboard or glass, they will arrange themselves along

the lines of force. A picture of the magnetic lines produced in this way is called a magnetic spectrum.

A bar magnet bent into a U shape is called a horse-shoe magnet, and it is interesting to get the magnetic spectrum of such a magnet. (See Fig. 20.) The region of powerful influence is smaller than with a bar magnet, but much more intense. The spectrum of two horse-shoe magnets attracting and repelling each other is very instructive.

A wire carrying a current has a very peculiar spectrum. This spectrum consists of concentric circles, denser near the wire than at a distance from it, as indicated in the sketch.

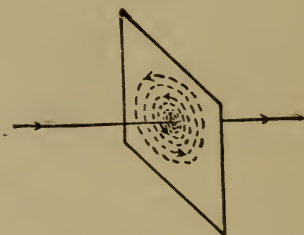

Figure 14

Magnetic spectrum of wire carrying current.

When the direction of the current is reversed, the direction of the lines is reversed. It is possible to find the direction of a current in a wire by the use of a compass by determining in what direction the concentric magnetic lines or magnetic whirl flows. A free north pole would move in the direction in which the magnetic lines flow, or would revolve around the wire. It is not possible, of course, to obtain a free north pole or a north pole without a south pole, so that all that can practically be discovered is the direction in which the north pole of a compass is moved. The direction in which the north pole is moved is the direction of the whirl, and the direction of the whirl bears the same relation to that of the current that the direction of rotation of a screw bears to its motion back and forth.



If the north pole of a compass moves in a right hand direction, it shows that the lines of force flow right handed and that the current is flowing away from the observer.

If the north pole of a compass is moved to the right when placed over a wire carrying current, it shows that the whirl is right handed and the current is flowing away from the observer.



Figure 15

Direction of current indicated by motion of compass needle placed under a wire carrying current,

If, on the other hand, it moves to the right when placed under the wire, it shows that the whirl is left handed and that current is traveling toward the observer.

It is a fact that when current is caused to circulate around an iron or steel core, the core becomes magnetized, and if the current is strong enough the core becomes much more strongly magnetized than is possible with permanent magnets. It is easy to get a magnet of such strength that the armature is attracted with a force of 125 pounds per square inch, and in extreme cases the magnetism of a piece of soft iron has been pushed to such an extent as to produce a magnetic pressure of 1,000 pounds per square inch. A piece of soft iron surrounded with such a circulating current becomes a powerful electro-magnet, but almost all the magnetism disappears when the current is withdrawn.

There is a relation between the polarity of an electro-magnet and the direction in which the current circulates around the magnet core. When the current circulates

around the magnet in the direction of the motion of the hands of a watch, the pole facing the observer in a S. pole.

A little thought will show that the magnetism of an electro-magnet may be regarded as the sum of the magnetic whirls of the wires surrounding the core. An inspection of Fig. 17 will show this.

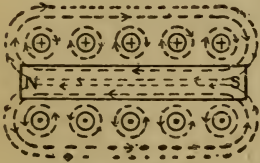

Figure 17

Showing that the magnetic lines of a helix or electromagnet are due to the addition of the magnetic whirls of the wires carrying the exciting current.

in an acid solution. The zinc and copper are connected with a helix. This helix will turn and point north and south in the same way a compass would. It is attracted or repelled by a permanent magnet in the same way that a compass is. If there were two of them floating in the same vat they would arrange themselves end to end with N. and S. poles adjacent.

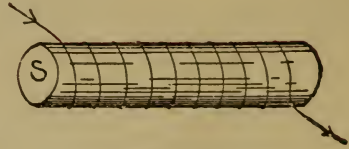

Figure 16

Relation between polarity of electric magnet and direction of exciting current.

A helix is a coil of wire carrying a current; the name is usually applied only to a single long spiral of wire. A piece of iron placed in a helix carrying current becomes an electro-magnet. A helix carrying current has all the properties of an electro-magnet, but the magnetic properties are not so powerful.

Fig. 18 shows a zinc and copper plate attached to a cork and floating

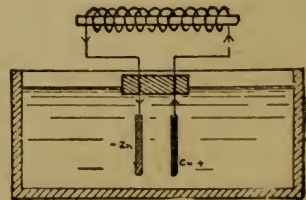

Figure 18  
Floating helix and electromagnet.

If now a piece of soft iron be placed in the helix all the above actions become much stronger, but this is the only difference. A piece of hard steel may be made into a permanent magnet by being inserted into a helix carrying current. A helix with a large number of turns is called a solenoid.

A very important relation exists between a wire carrying a current and a magnetic field. A magnetic field is a space through which the magnetic lines travel.

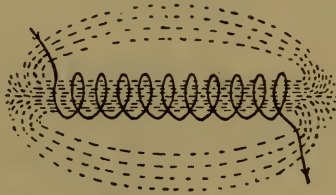

Figure 19

Magnetic spectrum of a helix; compare with spectrum of bar magnet.



Figure 20

Wire carrying current in a magnetic field tending to move in or out of the magnet.

Fig. 20 shows a horse-shoe magnet and in such a magnet the most powerful field exists between the ends. Fig. 20 also shows a wire placed in this field and at right angles to the plane of the magnet. If, now, current be sent through this wire, it will experience a mechanical force tending to move it sideways across the lines of force, either into or out of the magnet.

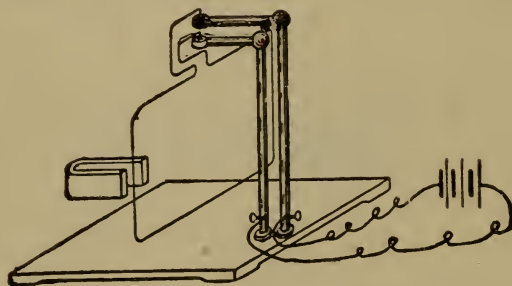

Figure 21

Fig. 21 shows a method by which a wire carrying a current and free to move may be arranged. This is a most important experiment, and, if possible, should be performed by every one interested in the study of electricity. The experiment shown in Fig. 21 is the fundamental experiment showing why it is that a motor will operate. By reversing the experiment shown in Fig. 21, and by causing the wire to move across the lines of force, it is possible to generate current in the wire. This is a fundamental experiment, for it shows in the simplest possible manner how mechanical power can be transformed into electrical power, or how a dynamo works. The relations that exist between the direc-

tion of motion of the wire, the direction of lines of force and the direction of the current in the wire when moved by hand or by mechanical force, is most easily remembered by extending the thumb, first and second finger of

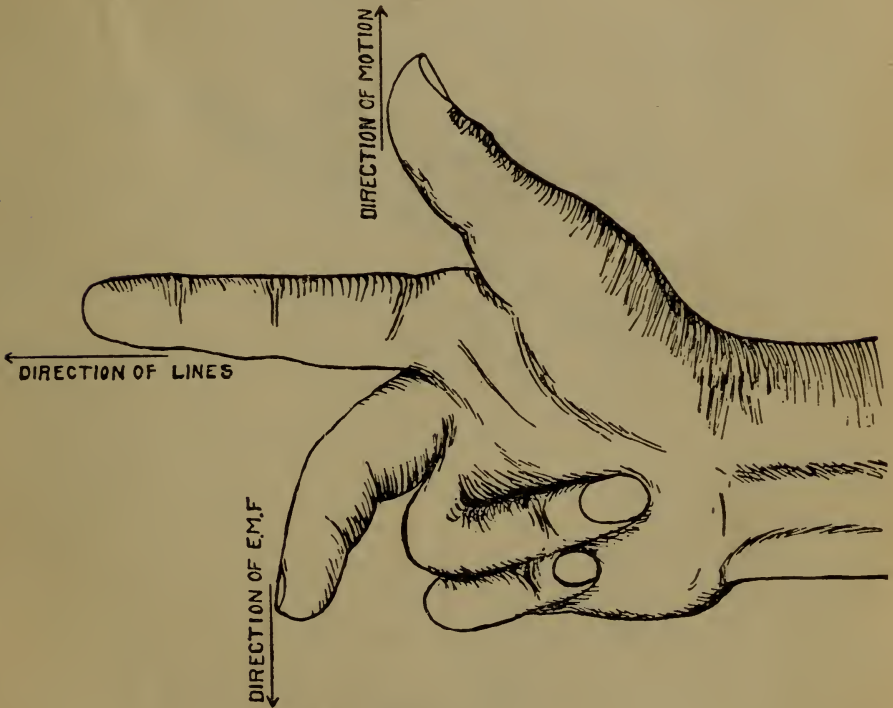

Figure 22

Rotation of direction of lines, motion and current illustrated.

the right hand at right angles to each other. When so extended the thumb points in the direction of the motion, the first finger points in the direction of the magnetic lines, and the second finger in the direction of the resulting current. The rule for remembering the direction of motion, lines and current when the wire is supplied with a current from

a battery or other source is the same as the case of a wire moved by mechanical force, given above, except that the thumb, first and second fingers of the left hand are used instead of the right.

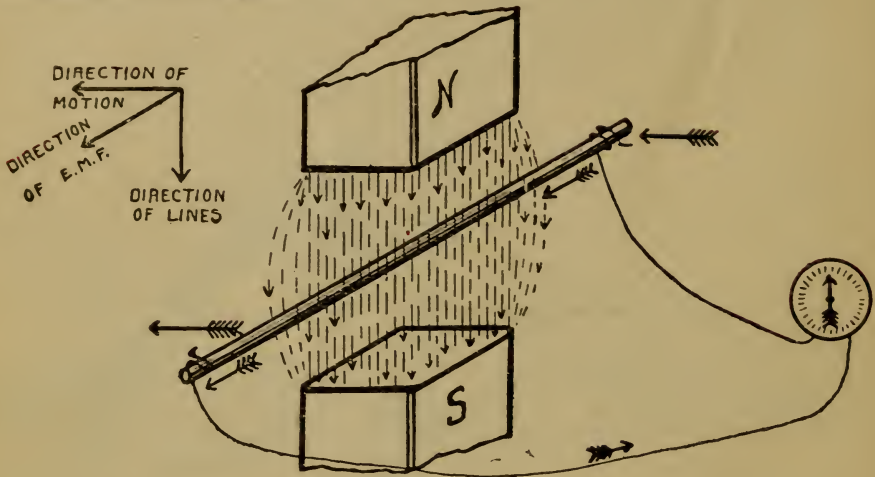

Figure 23  
Production of E. M. F. by moving wire in magnetic field.

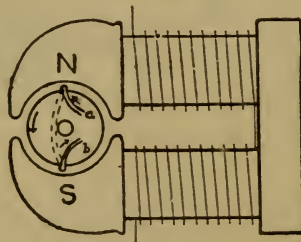

Figure 24  
Passage of current through a loop in a motor  
and resulting motion.

Fig. 24 shows an electric motor in which the rules given above may be applied. In Fig. 24 the N. pole is shown at the top and consequently the magnetic lines flow downwards, across the upper air gap and through the ar-

mature iron and across the lower air gap. If, now, current flows from some external source through the loop from A to B, the wire in the upper gap will be forced to the left.

As the current in the other side of the loop will be flowing in the opposite direction to that in the upper side, this part of the loop will be forced to the right; thus the wire in the upper air gap and the wire in the lower gap both tend to rotate in a direction opposite to that of the hands of a watch. Since the direction of the current in all the wires in the upper air gap in an actual armature is the same, each of these wires will be forced to the left and in a similar manner each of the wires in the lower air gap will be forced to the right. The sum of the mechanical forces acting on the wires in the upper and lower air gaps is the torque or twisting effort of the armature. The mechanical force depends on two things, viz: the number of magnetic lines flowing across the air gap and the current flowing in each wire. When a wire one foot long is in a field of an intensity of 100,000 lines per square inch, there will be a mechanical force of .106 pounds or 1.7 ounces pushing the wire sideways for every ampere of current flowing in the wire. It is clear now why it is so necessary to fasten the wires to the armature by bands, for it is not the iron which tends to move, but the wire on the outside of the iron, and in order to communicate the torque from the wire to the iron some such means are necessary.

Fig. 25 shows the same machine as Fig. 24, except that the armature is driven in the opposite direction by mechanical power. We have the north pole at the top and the current tending to flow through the wire in the same direction as in Fig. 24. There will be a drag on each wire

proportional to the number of lines which flow across the upper air gap through the armature and across the lower air gap, and also proportional to the current which is flowing in each wire.

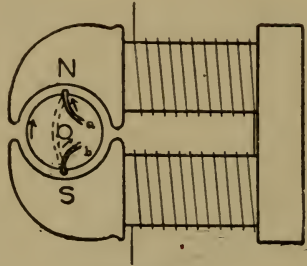

Figure 25  
Motion of a wire in a magnetic field and the resulting current.

Since there is the same mechanical drag in each wire in the upper air gap and an equal mechanical drag in the opposite direction in each wire in the lower air gap, it requires a mechanical torque or twisting effort on the armature to force the wires carrying the current through the air gaps. It sometimes happens that when very excessive currents pass through the wires on an armature the mechanical drag is such that the wires slip over the surface of the iron, usually cutting through the insulation at some point and burning out the armature. This is one advantage of the modern tunnel wound armature, for its construction gives an almost perfect mechanical support to the armature wires. When a wire moves so as to cut 100,000,000 lines of force per second, there is produced in this wire an electromotive force of one volt. It will pay the student to perform the experiments illustrated in this chapter, as he can in this way gain a first-hand knowledge of the fundamental principles upon which the operation of motors and dynamos depend which can be secured in no other way.



### QUESTIONS ON CHAPTER III.

1. What happens if a hard piece of steel is brought contact with a magnet?
2. What is a mariner's compass?
3. What is the north pole? The south pole?
4. What is a field of force?
5. In what direction do magnetic lines flow?
6. What is a magnetic spectrum?
7. What is peculiar in the magnetic spectrum of a horse-shoe magnet?
8. Describe the magnetic spectrum of a wire carrying a current.
9. What is a magnetic whirl?
10. What is the relation between the direction of flow of current in a wire and the direction of the magnetic whirl?
11. If the current in a vertical wire moves the north pole of a compass to the right when the compass is held between the wire and the observer, in what direction does the current flow?
12. A wire running north and south causes the north pole of a compass placed over it to be deflected toward the west; which way is the current flowing in the wire?
13. A lineman wished to learn the direction of the current in a wire over his head and observed that the com-

pass needle when held over the wire face down was deflected toward the east, the wire running north and south. In what direction does the current flow in the wire?

14. What is an electro-magnet?

15. What is the difference between a permanent magnet and an electro-magnet?

16. What is the relation between the polarity of an electro-magnet and the direction in which the current circulates around the iron core?

17. Is there any relation between the polarity of an electro-magnet and the magnetic whirls in the wires of which it is composed? If so, what?

18. What is a helix? What are its properties?

19. What is the difference between a helix and an electro-magnet?

20. When a wire carrying a current is placed in the field of a horse-shoe magnet, what occurs?

21. Explain the action of the mechanism in Fig. 20 when it operates as a motor.

22. Explain its action when it operates as a dynamo.

23. What is the relation between the direction of the motion, direction of the lines and the direction of the current when the apparatus is used as a dynamo?

24. What is the relation between the direction of the motion, the direction of the lines of force and the direction of the current when the apparatus is being used as a motor?

25. Why will the armature in Fig. 21 reverse its direction of motion if the north pole were placed at the bottom instead of at the top?

26. Why is it that both wires in the loop in Fig. 21 tend to rotate the armature in the same direction?

27. We have seen that the earth is a great magnet, with its south magnetic pole near its north geographical pole. If a person is riding a bicycle toward the west, in what direction will the E. M. F. be generated in the vertical spokes in the moving wheel?

28. If a current is traveling in a coil of wire that is free to move, and the coil turns so that its plane is east and west, in what direction will a current be flowing in this coil?

29. Two men standing in an east and west line, 50 feet apart, raise a steel tape from the ground. In what direction does the current tend to flow along the steel tape?

30. In an Edison motor the armature is revolving right-handed as seen by the observer. If the pole on the left is a north pole, in which direction does the current flow in the wires under the north pole?

31. When a wire is in a field of 100,000 lines per square inch, what is the mechanical force acting on the wire per ampere per foot?

32. How many magnetic lines must be cut per second to produce one volt?

33. Is there any other reason for banding down armature wires to the core except to prevent the action of centrifugal force?

## CHAPTER IV.

### THE MAGNETIC CIRCUIT.

De La Rives' floating battery (Fig. 18) showed that a helix carrying a current is a magnet. If the current is measured and the number of turns counted, it will be found that the strength of a given helix depends on the number of amperes of current that flow through it, and if a constant current is used the strength of the helix depends on the number of turns.

Putting these two facts together, we see that the strength of any helix is proportional to the product of the number of turns times the number of amperes or the ampere turns. The number of ampere turns is a measure of the magnetizing force. By producing the magnetic spectrum of a helix (Fig. 19) it will be seen that all the lines traverse the center of the helix and return through the space outside of the helix. If the diameter of the helix is large, more lines will flow through it than if it is small. If it is short, more lines will flow through it, other things being equal, than if it is long. A careful consideration of these experiments will show that there is the same relation between the number of lines of force and the magnetizing force or number of ampere turns and the magnetic resistance that there is between the current, voltage and resistance in the electric circuit. If we allow  $N$  to represent the number of lines of force produced,  $A T$  to represent the

number of ampere turns, and  $M R$  to represent the magnetic resistance or reluctance, we have  $N$  equals  $A \cdot T$  divided by  $M R$ , or  $\frac{A T}{M R}$ . It will be noticed at once that this is Ohm's law transferred to the magnetic circuit.

The magnetic resistance is proportional to the length of the magnetic circuit and is inversely proportional to the

area of  $M R$  equals  $\frac{l}{A}$ , where  $l$  is the length of the magnetic

circuit and  $A$  equals the area. Substituting this in the formula we have

$$N \text{ equals } A \cdot T \text{ multiplied by } \frac{A}{l}$$

If  $A$  and  $L$  be expressed in inch measurements, we have

$$N \text{ equals } \frac{A \cdot T \text{ multiplied by } A}{l \text{ multiplied by } .3132} \quad (4)$$

We will now see what effect the introduction of iron into the helix will have. Figs. 18 and 19 show that current flowing in a helix produces lines of force in the helix and causes it to become a weak magnet. If a piece of soft iron be inserted in the helix, the iron becomes very strongly magnetized.

It can be shown that a great many more magnetic lines of force traverse the helix when it has the iron inside than before. Therefore the iron offers an easier path for the magnetic lines than the air did because more lines flow under the same circumstances when the helix is filled with iron than when the iron is absent. Under some circum-

stances the iron will transmit or allow to pass 3,000 times as many lines as the air.

The presence of the iron multiplies the number of magnetic lines by offering an easier path for the flow of the lines. If it was not for this multiplying action of the iron, dynamo electric machinery would be impossible. That property of iron, in virtue of which it conducts magnetic lines, is called permeability.

Now the permeability of iron is not constant. When only a few lines are flowing in a piece of iron the permeability or multiplying power is greatest. If the iron is already carrying a large number of lines the permeability will be small.

The capacity of the iron for carrying lines may be compared to the capacity of a sponge for soaking up water.

When the sponge has only a little water in it, it will readily absorb more, but when the sponge has taken up nearly as much water as it will, or is saturated, it will absorb more water only with reluctance. When iron is carrying about as much magnetism or as many magnetic lines as it will, it is said to be saturated. The permeability of iron at various numbers of lines per square inch in the iron or at various degrees of saturation has been measured, and the results obtained are shown in the following table:

TABLE VI.

## TABLE OF PERMEABILITY

WROUGHT IRON				CAST IRON			
Lines per Square Inch	Permeability or Multiplying Power of Iron	Lines in Air	Ampere Turns per Inch in Length	Lines per Square Inch	Permeability or Multiplying Power of Iron	Lines in Air	Ampere Turns per Inch in Length
30,000	3,060	9.8	3.06	25,000	833	30.0	9.4
40,000	2,780	11.4	4.72	30,000	580	51.7	10.2
50,000	2,483	20.1	6.29	35,000	390	89.7	27.5
60,000	2,173	28.0	8.76	40,000	245	163.	51.
65,000	1,980	32.8	10.26	45,000	135	333.	104.
70,000	1,920	40.7	12.7	50,000	110	454.	142.
75,000	1,500	50.0	15.6	60,000	66	909.	284.
80,000	1,260	63.5	19.8	70,000	40	1750.	548.
85,000	1,030	82.5	25.8				
90,000	830	108.0	33.8				
95,000	610	156.	48.8				
100,000	420	238.	74.5				
105,000	280	375.	117.				
110,000	175	629.	197.				
115,000	95	1210.	378.				
120,000	60	2000.	626.				
125,000	40	3125.	978.				
130,000	30	4333.	1356.				
135,000	24	5626.	1761.				
140,000	18	7777.	2434.				

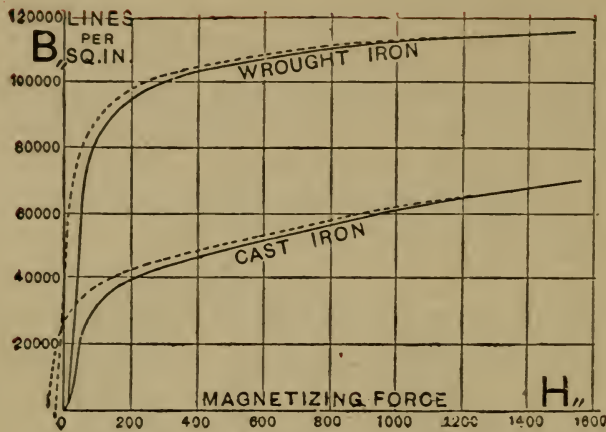

### B. H. Curve

Curves showing the same relations graphically that the table gives numerically.

This table was calculated by measuring the number of magnetic lines flowing through an iron ring surrounded by a certain number of turns of wire (see Fig. 27) and comparing this with the number that would flow through the air when a wire coil of the same size, carrying the same current, was tested in the air (see Fig. 26).

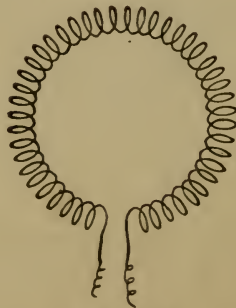

Figure 26  
Coil of wire in air.



The number of lines flowing in the coil in Fig. 26 may be calculated by Formula 4, or measured by coil and galvanometer as in Fig. 27.

Fig. 27 shows the same coil as in Fig. 26, except that the coil is filled with iron instead of air.

The number of lines flowing may be measured with a small coil and galvanometer. By passing the same currents through both coils in Figs. 26 and 27 and comparing the number of magnetic lines produced, the permeability of the iron is found.

If there are 100 turns in each coil, and one ampere is flowing through each coil, suppose current in coil in Fig. 26 produces 100 lines and current in coil in Fig. 27 produces 185,000 lines, then the permeability of the iron is 185,000 divided by 100 equals 1,850 at this stage of saturation.

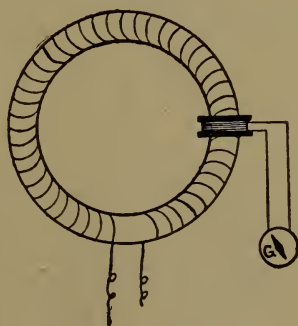

Figure 27  
Same coil as in Figure 26 with iron core.

In the above table the first column represents the number of lines of force which flow through the iron. The second column is the permeability or multiplying power of the iron. The third column is the number of magnetic lines

there would be in air. The fourth column is the ampere turns required to force the magnetic lines through one inch of iron at the given density. The first part of this table is devoted to ordinary wrought iron and may be used in a general way to represent the magnetic properties of charcoal and sheet iron, soft sheet steel and cast steel.

The second part of this table represents the properties of ordinary cast iron.

It must be carefully kept in mind that while these tables give a general idea of the magnetic properties of iron, no two specimens of iron are exactly alike, and if it is desired to get an accurate knowledge of the magnetic qualities of any particular sample of iron, it is necessary to make a separate test for this sample and construct a table similar to table No. 5 for each sample. It will be noticed that in a general way wrought iron conducts the magnetic lines about twice as well as cast iron.

When formula (5) is revised, so as to introduce the permeability of the iron, it becomes  $N$  equals  $\frac{a. t. \times A \times \mu}{l \times .3132}$  (5)

in which  $\mu$  represents the value of the permeability.

We will now take an example and calculate the ampere turns required to force a given number of magnetic lines through the various parts of the magnetic circuit. We will select the Edison type of bi-polar dynamo for this calculation. The easiest way to make this calculation is to find the number of ampere turns required in each part of the magnetic circuit and add together the numbers so found.

In this example we will find the number of ampere turns required in the yoke, which is of wrought iron, next that required in each magnet core, next that required in each pole piece, then that required in each air gap and last that required in the armature iron.

In Fig. 28 the dimensions of the parts have been indicated and the approximate length of the average magnetic line is shown. Let us suppose that 4,500,000 magnetic lines flow through the magnetic circuit of this dynamo. This will cause 4,500,000 divided by 54, or 83333, to flow per square inch through the yoke. The following formula may

$$N \times l \times .3132$$

be deduced from formula 4: A. t. equals  $\frac{N \times l \times .3132}{A \times \mu}$  (6), in

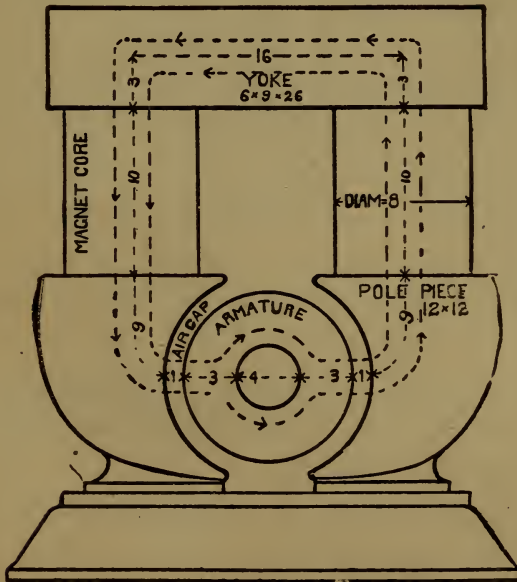

Figure 28  
Magnetic circuit of Edison bipolar dynamo.

which  $N$  equals the total flow of magnetic lines in the part of the magnetic circuit considered,  $l$  equals length in inches of this part of the magnetic circuit,  $A$  equals area in square inches of this part of the magnetic circuit;  $\mu$  equals the permeability of this part of the magnetic circuit, with the particular value of  $N$  that may exist and the value of  $\mu$  must in each case be found from the table. Substituting these quantities in formula (6) we have for the yoke  $N$  equals 4,500,000;  $l$  equals 22 inches;  $A$ , or the area of the cross section of the magnetic circuit in square inches, which in this case equals 6 multiplied by 9, or 54; and  $\mu$ , or the permeability, equals 1,107. This is found by consulting the table, in which it is seen that the permeability of wrought iron equals 1260 at 30,000 lines per square inch. That the permeability at 85,000 lines per square inch is 1030. The permeability of 83,333 lines will be approximately 2-3 the difference between these two permeabilities, or 1260—153 or 1107.

$$\text{a. t. equals } \frac{4,500,000 \times 22 \times 3132}{54 \times 1107} \text{ equals } 520$$

The a. t. required in the magnet core will be found by substituting for  $N$ , 4,500,000 as before, for  $l$  or length of this part of the magnetic circuit, 10 inches.

For  $A$ , or the cross section of the magnetic circuit at this point, we have 50.26 square inches, which is the area of a circle 8 inches in diameter.

To ascertain the value of  $\mu$  it is necessary to find out how many lines per square inch flow through the magnet core. In order to do this, divide 4,500,000 by 50.26, which gives 89,534 lines per square inch. This is sufficiently close

to 90,000 lines to take the permeability of 90,000 lines from the table, and, substituting 830 for the value of  $\mu$ , we have

$$\text{a. t. equals } \frac{4,500,000 \times 10 \times .3132}{50.26 \times 830} \text{ equals } 338$$

Next we take up the number of a. t. required in the pole piece. This is of cast iron and the area of cross section is indicated in the sketch as being 12 inches x 12 inches, or 144 square inches.

The flux per square inch is 4,500,000 divided by 144 equals 31,250. The ampere turns required in this part of the magnetic circuit would be

$$\text{a. t. equals } \frac{4,500,000 \times 9 \times .3132}{144 \times 532} \text{ equals } 166$$

It must be kept in mind that the pole pieces are of cast iron and therefore the permeability is much lower than if they were of wrought iron.

The ampere turns required in the air gap are

$$\text{a. t. equals } \frac{4,500,000 \times 1 \times .3132}{138 \times 1} \text{ equals } 10,213$$

The air gap in an actual dynamo is partly filled with copper wire and insulation, but this conducts magnetic lines no better than air.

The area of the air gap is calculated on the assumption that the pole pieces embrace two-thirds of the circumference of the armature. As per the sketch, the pole piece is 12 inches long and the average diameter of the air gap is

11 inches, and the circumference of a circle 11 inches in diameter is 34.54 inches. One-third of this is 11.5 and the area of the air gap is  $11.5 \times 12$  equals 138 square inches.

It will be noticed that the number of ampere turns required in the air gap is vastly greater than that required in any other part of the magnetic circuit, and is a good example of how much better a conductor of magnetic lines iron is than air or any ordinary material. The ampere turns required in the armature iron are

$$\text{a. t. equals } \frac{4,500,000 \times 9 \times 3.132}{72 \times 2077} \text{ equals } 84$$

In this part of the circuit the area of cross section of the magnetic circuit is taken as 6 multiplied by 12 inches equals 72 square inches, because the shaft is 4 inches in diameter, and for reasons that will appear later the lines cannot flow across the shaft when the armature is in motion.

There are two coils on the dynamo, one on each magnet core, and each of these two are of equal power and each does half the work of driving the magnetic lines around the circuit. If we wish to find the number of ampere turns that each should supply, we must add together half those required for the yoke, all in one magnet core, all in one pole piece, all in one air gap, and half those in the armature iron. Gathering these results together, we have:

Half a. t. required in yoke.....	260
All a. t. required in magnet core.....	338
All a. t. required in pole piece.....	166
All a. t. required in one air gap.....	10,213
Half a. t. required in armature iron..	42
<hr/>	
Total a. t. required in half of mag- netic circuit .....	11,019

Each of the two coils will then be required to produce 11,019 ampere turns in order to force 4,500,000 magnetic lines around the magnetic circuit.

The method of calculating the size of wire required in the coil to produce this number of ampere turns will be explained in one of the succeeding chapters.

The Edison type of dynamo is an excellent example of the older style of dynamos that were built eight or ten years ago. The prevailing style for large machines at the present time has the multipolar field and ironclad armature.

The ironclad armature is well adapted for all sizes of machines, while the multipolar construction is especially advantageous in machines of large output, but for machines of less than 10 H. P. is not so good as the bipolar construction, as will be explained in the chapter on Hysteresis and Eddy Currents.

Figs. 29 and 30 show diagrams of the two styles of armature in the same field frame.

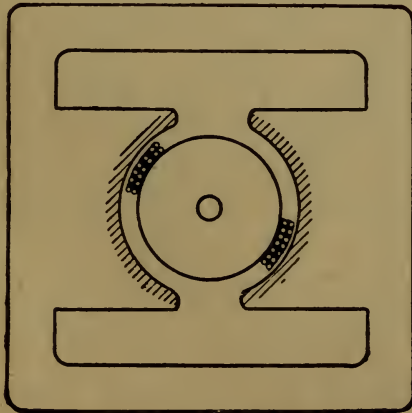

Figure 29  
Smooth core armature.

The chief reason that ironclad armatures have come into use is that by means of this device the magnetic resistance of the air gap is very much reduced.

The practical effect of the introduction of the ironclad armature is to make the carrying capacity of the iron of the magnetic circuit the limit of the flux through the circuit.

The resistance to the magnetic flux in the air gap of the ironclad armature is not over one-fifth that in a smooth core armature of the same capacity. The ironclad armature may be run so that there is only enough room between the armature iron and the iron of the field frame to permit of mechanical rotation.

It will be noticed that the wire on the ironclad armature is buried in slots, cut in the armature. This protects them from mechanical injury, and, more important still,

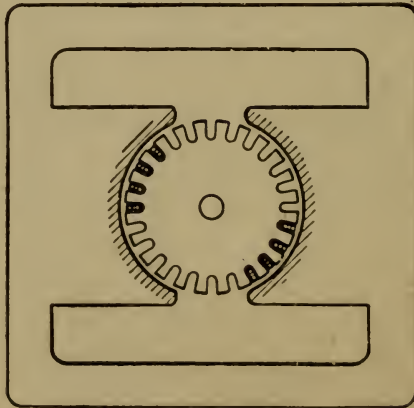

Figure 30  
Iron clad armature.



gives them perfect mechanical support, so that there is no tendency to slide or move from their places as there is in the smooth core armature.

Practically all of the magnetic flux that passes into the armature must get through the bottom of the iron teeth of the armature, and the area of this part of the magnetic circuit determines the total flux that can be used.

We will now calculate the ampere turns required in a bi-polar machine with an ironclad armature, and also the ampere turns required in a six-pole field with ironclad armature.

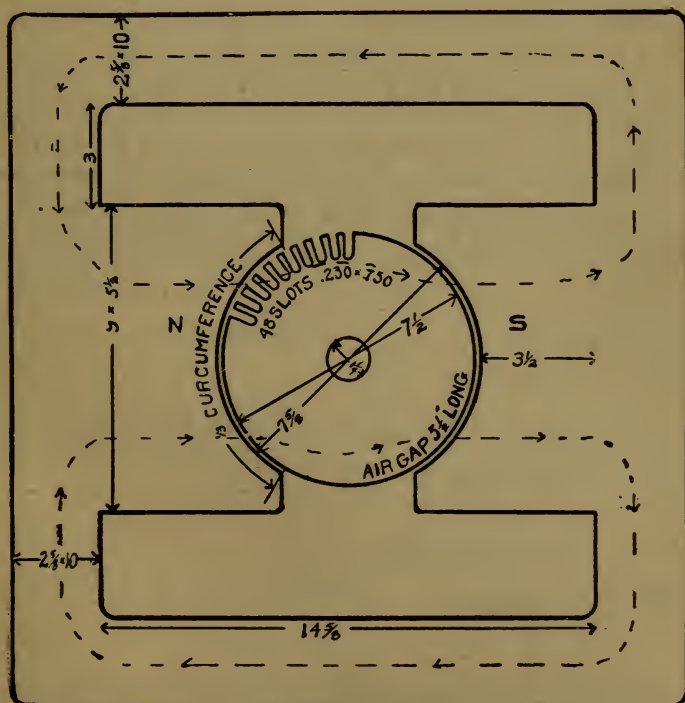

Figure 31  
Magnetic circuit of 5 H. P. bipolar machine with iron clad armature,  
and cast iron field frame.

The bipolar machine is shown in Fig. 31 and the dimensions are those actually used in a 5 H. P. motor.

It will be noticed that in this machine the yoke is in two parts and half of the flux flows through each part.

The frame is so designed that the flux is most dense in the frame in the pole pieces. The sectional area of the pole pieces is shown in Fig. 32. The area will be  $9 \times 5\frac{1}{2}$  or  $49\frac{1}{2}$ , less what is cut off of the corners. A circle 3 inches in diameter has an area of about 7 square inches, which is 2 square inches less than a surface 3 inches square, so that the area of the pole piece will be  $49\frac{1}{2}$  minus 2 equals  $47\frac{1}{2}$  square inches.

This machine has a flux of 2,100,000 lines. At this flux the density in the pole piece will be 2,100,000 divided by  $47\frac{1}{2}$  equals 44,210.

The average length of the magnetic line in each pole piece is 4 inches.

The permeability of cast iron at 44,200 is 153. Substituting in the formula No. (6) we have

$$\text{a. t. equals } \frac{2,100,000 \times 4 \times 3.132}{47.5 \times 153} \text{ equals } 362 \text{ in each magnet core.}$$

The flux in the yoke can all be calculated at the same time, for the density all through the yoke is the same, and consequently the value of the permeability or  $\mu$  is the same.

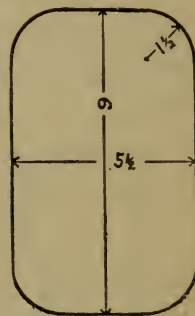

Figure 32  
Calculation of  
Sectional  
area of pole piece.

flux is 2,100,000 divided by  $(2\frac{5}{8} \times 10 \times 2)$  equals 2,100,000 divided by 52.5 equals 40,000. The permeability at 40,000 lines per square inch in cast iron is 245. Substituting we have

$$\text{a. t. equals } \frac{2,100,000 \times 12 \times .3132}{52.5 \times 245} \text{ equals } 613$$

in each half of the yoke.

The area of the air gap is not the whole area of the pole face, for with an air gap 1-16 inch long there is a bunching of the lines to a greater or less extent, as shown in Fig. 33.

It is important to calculate the area of the air gap carefully, for on this will depend the number of a. t. in the air gap, and this number is much greater than that for any other part of the circuit, and an error in this calculation will have a greater effect on the total result than in any other.



Figure 33  
Bunching of magnetic lines in air gap.

There are 48 slots in a disc  $7\frac{1}{2}$  inches in diameter and each slot is .230 inches wide; the circumference of the disc is 23.55. Each slot and tooth take up 23.55 divided by 48 equals .491. This leaves the top of the tooth .491— .230 equals .261 wide. The lines will spread from the top of the teeth to the iron pole piece. Each pole piece embraces or covers 16 teeth. Experience teaches that it is safe to assume that the lines spread from the top of the teeth, so that the top of the tuft is equal in width to the top of the tooth plus twice the width of the air gap, but the average

width will be only half this. The average width of the tuft will be .261 plus .062 equals .323.

Since the length of the armature is  $5\frac{1}{2}$  and there are 48 teeth in the armature, we have 16 tufts of lines each  $5\frac{1}{2}$  inches long x .323 wide. The area of the air gap is then  $16 \times 5.5 \times .323$  equals 28.4. Substituting we have

$$\text{a. t. equals } \frac{2,100,000 \times 1 \times .3132}{28.4 \times 16} \text{ equals } 1447$$

The magnetic lines are very much crowded in the armature teeth, and the density changes at each point in the length of the teeth, so that theoretically a separate calculation would have to be made for each part in the length of the tooth. A sufficiently close approximation, however, may be made by making two calculations, one for the ampere turns required for a length of  $\frac{1}{8}$  inch at the bottom of the teeth and the other for the rest of the tooth.

It is first necessary to find the area of the bottom of the teeth.

The slots are  $\frac{3}{4}$  inch deep, .230 inches wide and round at the bottom. This being so, the narrowest place in the tooth will be .750 minus .115 equals .635 from the outside of the disc, for there is a circle .230 in diameter at the bottom of the slot.

The circumference of a circle whose periphery passes through the narrowest part of the tooth is

$$3.1416 \times [7.5 - .635 \times 2] \text{ equals } 3.1416 \times 6.23 \text{ equals } 19.57.$$

$$1.48 \text{ of this circumference equals } .408.$$

.408—.230 equals .178 inches, which is the width of the tooth at its thinnest point.

The area of the tooth at the bottom is  $.178 \times 5.5 \times 16$  equals 15.66.

The flux at the bottom of the teeth is 2,100,000 divided by 15.66 equals 134,100.

The permeability at this flux is 30—4-5(30—24) equals 25. Substituting

$$\text{a. t. equals } \frac{2,100,000 \times 1 \times .3132}{15.66 \times 8 \times 25} \text{ equals } 210$$

As indicated above, the ampere turns in the rest of the tooth may be found in one calculation. The width of the teeth in the narrowest place is .178 and in the widest place

is .261. The average width is then  $\frac{.261 + .178}{2}$  equals .219.

The average area of the teeth will be

$$.219 \times 5.5 \times 16 \text{ equals } 19.3 \text{ square inches.}$$

This area gives a flux of 2,100,000 divided by 19.3 equals 109,000, and the permeability at this density is 280—4-5 (280—175) equals 196. Substituting we have

$$\text{a. t. equals } \frac{2,100,000 \times 5 \times .3132}{19.3 \times 8 \times 196} \text{ equals } 108$$

The last calculation to make is ampere turns required for the armature iron.

The area of iron carrying lines is  $5\frac{1}{2} \times [7\frac{1}{2} - (1\frac{1}{2} + 1\frac{1}{4})]$  equals  $4\frac{3}{4} \times 5\frac{1}{2}$  equals 26.1.

The flux per square inch will be 2,100,000 divided by 26.1 equals 80,460.

The permeability at this density equals 1,237.

The a. t. required for armature iron

$$\text{a. t. equals } \frac{2,100,000 \times 5 \times .3132}{26.1 \times 1237} \text{ equals } 102$$

Collecting our results we have:

A. t. required in each magnet core.....	362
A. t. required in each half of yoke.....	613
A. t. required in each air gap.....	1,447
A. t. required in bottom of teeth on one side..	210
A. t. required in body of teeth on one side....	108
A. t. required in half armature iron.....	51
A. t. required in half magnetic circuit.....	2,791

We must then have two coils each with a magnetizing power of 2,791 ampere turns, or one coil with a magnetizing power of twice this, in order to force 2,100,000 lines around the circuit. It will be noticed that the number of ampere turns required in the air gap is over one-half the total ampere turns required. A little thought will show also that a small decrease in the flux would decrease the magnetizing power very greatly, and, if it was necessary to force a little more flux through the circuit, a great deal more magnetizing power would be required. This is because the iron in the motor just calculated is almost saturated, and in some parts of the circuit is saturated. A small decrease in the flux would very greatly **increase** the permeability and so decrease the magnetizing power required in these parts of the iron magnetic circuit.

It will be seen that it is not possible to obtain exact results in making these calculations, for the permeability of the actual iron may be more or less than that given in the table.

It will usually be found that the table is a little high for wrought iron and cast steel and about right for good soft sheet steel. The writer has used samples of cast iron

that were better than those given in the table, and also some that were worse. It is easy to get cast iron as good as that shown in the table.

An equally close approximation to the ampere turns required in the iron part of a machine may be had by taking the ampere turns required for one inch of iron at a density given by the table.

Use the density closest to the one required, and if any mistake is made, make the result too large rather than too small.

The ampere turns required in the magnetic circuit of the six-pole machine shown in Fig. 34 has been obtained in this way.

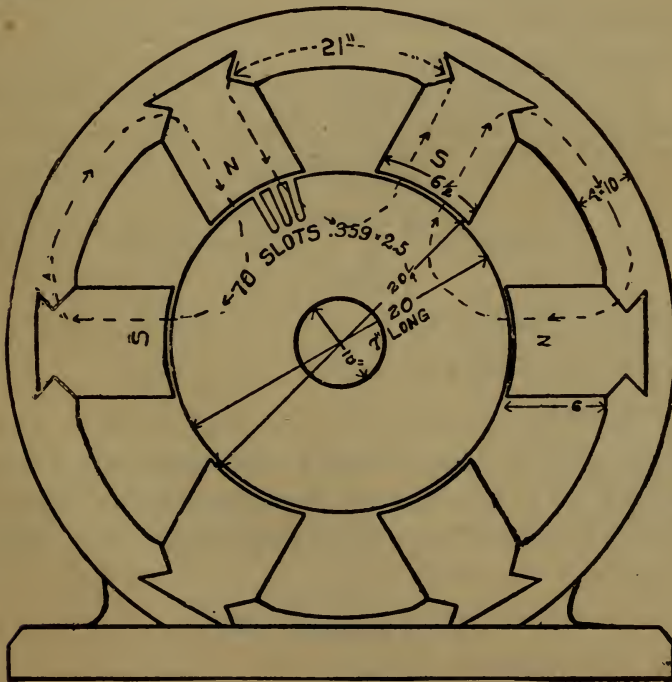

Figure 34  
Magnetic circuit of a 100 K. W. Westinghouse dynamo.

These figures are taken from a Westinghouse 100 K. W. dynamo.

In this machine we will make six calculations, for the pole pieces are made of thin pieces of sheet iron riveted together. This makes the pole piece wrought iron and the yoke cast iron, and thus requires two calculations for this part of the magnetic circuit. In these calculations the following notation will be used:

O equals number lines per square inch.

l equals average length of magnetic circuit in the part of machine under consideration.

A equals cross sectional area.

$\mu$  equals permeability.

a. t. equals ampere turns.

For the laminated pole piece

$$O \text{ equals } \frac{2,500,000}{6\frac{1}{2} \times 7} \text{ equals } 55,000$$

l equals 7.

A equals  $45\frac{1}{2}$  square inches.

$\mu$  equals 2331.

From table No. 6 it is found that it will take 7.53 a. t. at this value of  $\mu$  to force the lines through one inch of the iron; therefore it will take  $7 \times 7.53$  equals 53 a. t. to force the lines through the whole of l.

For the yoke which is of cast iron

A equals 40 square inches.

l equals  $10\frac{1}{2}$  inches.



$$O \text{ equals } \frac{2,500,000}{2 \times 40} \text{ equals } 31,250$$

a. t. per inch equals 14.6.

Total a. t. equals  $10.5 \times 14.6$  equals 153.

For the air gap:

l equals  $\frac{1}{8}$  inch.

Width of top of tooth

$$\frac{20 \times 3.1416}{70} - .359 \text{ equals } .539$$

Number of teeth under each pole 7.4.

Average width of air space between one tooth and pole face equals  $.539 + .125$  equals .664.

A equals  $.664 \times 7.4 \times 7$  equals 34.4.

$$O \text{ equals } \frac{2,500,000}{34.4} \text{ equals } 72680$$

More accurate results will be obtained by using formula (6) in calculating the a. t. in the air gap, for in this part of the magnetic circuit there is no value of  $\mu$  to be inserted. Substituting in formula (6) the a. t. required for the air gap is found to be

$$\text{a. t. equals } \frac{2,500,000 \times 1 \times 3.132}{34.4 \times 8} \text{ equals } 2845$$

A. t. required in  $\frac{1}{8}$  inch at bottom of tooth.

l equals  $\frac{1}{3}$  inch.

Diameter of circle through the thinnest part of tooth equals  $20 - 5 + .359$  equals 15.359 inches.

Width of tooth here

$$\frac{3.1416 \times 15.359}{70} - .359 \text{ equals } .330.$$

A equals  $.330 \times 7.4 \times 7$  equals 17.1.

$$\text{O equals } \frac{2,500,000}{17.1} \text{ equals } 146,200.$$

146,200 lines per square inch is beyond the limits of the table, but it will require about one-fifth more ampere turns per inch over 2,434 as the difference between the a. t. required at 135,000 and 140,000, or  $2434 + [6 - 5(2434 - 1761)]$  equals 3242. Hence

A. t. equals  $\frac{1}{8} \times 3242$  equals 405.

A. t. required in remainder of tooth:

L equals  $2.5 - \frac{1}{8}$  equals  $2\frac{3}{8}$ .

$$\text{A equals } \frac{(.330 + .539)}{2} \times (7.4 \times 7) \text{ equals } 22.5 \text{ square inches.}$$

$$\text{O equals } \frac{2,500,000}{22.5} \text{ equals } 111,110.$$

A. t. equals  $2\frac{2}{3} \times 237$  equals 563.

A. t. required in rest of armature iron:

If the shaft and spider are 10 inches in diameter, the area of armature iron carrying lines equals  $20 - (5 \div 10) \times 7$  equals  $5 \times 7$ .

A equals  $5 \times 7$  equals 35.

L equals  $3\frac{1}{2}$  in one-half of armature.

O equals  $\frac{2,500,000}{35}$  equals 71,500.

A. t. equals  $3\frac{1}{2} \times 13.6$  equals 47.

Summarizing our results we have:

A. t. in one pole piece.....	53
A. t. in yoke .....	153
A. t. in air gap.....	2,845
A. t. in bottom of teeth.....	405
A. t. in body of teeth.....	563
A. t. in armature iron .....	47
Total .....	4,066

The coil on each pole piece will have to be capable of producing 4,066 ampere turns in order to force 2,500,000 lines through each one of the six magnetic circuits.

## QUESTIONS ON CHAPTER IV.

1. On what does the strength of a helix carrying a current depend?

2. Is there any relation between the number of magnetic lines generated by a current in a helix, the magnetizing power of the helix and the magnetic reluctance offered by the path which the lines take? If so, what?

3. If the equation of a magnetic circuit be compared to Ohm's law what quantity in the magnetic circuit corresponds to the current? What corresponds to the voltage?

4. To what is the magnetic resistance of a circuit proportional?

5. What is the effect of the introduction of iron into a helix?

6. Why is it that a number of magnetic lines traversing a circuit is increased more by placing a piece of iron inside the helix than by filling the space around the outside of the helix with iron?

7. How many magnetic lines will flow through a helix three inches in diameter and five and one-half inches long upon the supposition that the magnetic lines meet with no resistance except that encountered passing through the inside of the helix; the helix has ninety-five turns and fifteen amperes?

8. If the number of amperes in the helix in No. 7 be increased to twenty-one how many magnetic lines will flow?

9. What is permeability?

10. Why is it true that Formula No. 4 is not true when iron is used in the magnetic circuit?

11. When is the permeability of iron low?

12. When iron contains a great many magnetic lines what is said of its magnetic condition?

13. Why is it that the magnetic circuit of a dynamo is almost entirely composed of iron?

14. How is the permeability table obtained?

15. What may be said in a general way of the permeability of wrought iron, common sheet iron, boiler plate and cast steel?

16. Is table No. 4 an exact representation of the permeability of any particular sample of wrought iron or steel?

17. In a general way what are the permeabilities of cast and wrought iron?

18. In calculating the number of ampere turns required for a magnetic circuit why is it usual to calculate the number in each part of the circuit and add them together?

19. How many ampere turns will be required to force 1,300,000 lines around the magnetic circuit shown in Fig. 35?

20. Give ampere turns required in half of yoke, in pole-piece, air gap, body of armature teeth, neck of armature teeth and in armature.

21. How many ampere turns will be required in each field coil in Fig. 34, provided 2,300,000 lines of force flow? Give ampere turns in each part of the magnetic circuit as in preceding question.

22. Why is it necessary to be more careful in calculating the dimensions of the air gap than with other parts of the magnetic circuit?

23. If a field core is made of cast steel, what will be its sectional area as compared with a core made of cast iron capable of carrying the same number of lines?

24. How many ampere turns will be required to force 1,000,000 lines around a ring averaging one foot in diameter, having a sectional area three and one-half inches in diameter?

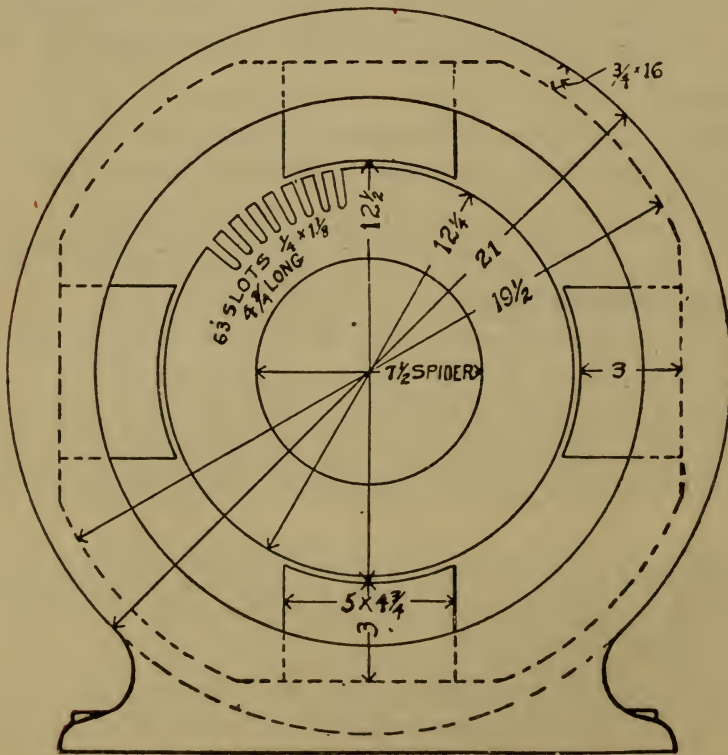

Figure 35

25. What, besides iron, are the magnetic metals?
26. Are the copper and insulation used on an armature more permeable than the air which they displace?
27. What is a smooth core armature?
28. What are the advantages of iron clad armatures?
29. What is the effect of using a toothed armature on the distribution of lines of force passing from the pole piece?
30. What is the area of the air gap in a dynamo having thirty-six teeth in the armature, one-third of the armature teeth under each pole; the armature teeth .310 inches wide at the top, the air gap one-sixteenth of an inch wide and five inches long?
31. How many ampere turns will be required in the air gap to produce a flux of 5,000 lines crossing the air gap between the poles of a horseshoe magnet and its armature where the area of the face of the magnet is one-half of one square inch and the air gap is one-fourth of an inch long?
32. What is the usual flux employed in the bottom of armature teeth?
33. What will be the effect of reducing the ampere turns ten per cent. in the motor shown in Fig. 29?
34. Why is it that the number of magnetic lines which flow through an air gap is proportional to the ampere turns acting on the air gap, while the number of magnetic lines flowing through the rest of the magnetic circuit is not proportional to the ampere turns?
35. Why is it impossible to obtain absolutely correct results in calculating the ampere turns required for the ampere turns of a magnetic circuit?

## CHAPTER V.

### MAGNETIC TRACTION.

It is a well-known fact that the north and south poles of two magnets attract each other. In fact, the magnetic lines act as if they were elastic cords that always tend to shorten themselves. When a great number of the magnetic lines flow across a given space the attraction is very strong.

Ewing, in some of his experiments, pushed the magnetism of a piece of soft iron to such a point that the pressure due to the magnetic attraction was 1,000 pounds per square inch.

Table No. VII gives the pull between a magnet and its armature when the given fluxes pass. The formula from which this table was calculated is

$$\text{Pull in pounds equals } \frac{B^2 A}{72,134,000} \quad (7)$$

in which B equals the flux in lines per square inch, A equals the area of cross section between magnet and armature in square inches.



TABLE No. VII.

Flux per sq. in. between armature and magnet.	Pull in lbs. per sq. in between armature and magnet.
5,000	.34
10,000	1.4
15,000	3.1
20,000	5.5
25,000	8.7
30,000	12.5
35,000	20.0
40,000	22.2
45,000	28.1
50,000	34.6
55,000	41.9
60,000	49.9
65,000	58.5
70,000	67.9
75,000	78.0
80,000	88.7
85,000	100.
90,000	112.
95,000	125.
100,000	138.
105,000	153.
110,000	168.
115,000	183.
120,000	199.
125,000	216.
130,000	234.
135,000	252.
140,000	272.

The best form of magnet for traction or lifting purposes is shown in Fig. 36.

Fig. 36 shows a cross section of a magnet and its armature. In this case it is desired to force as many lines of force as possible across the joint between the armature and magnet and also to reduce this area as much as

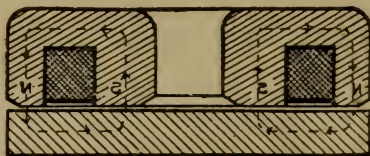

Figure 36  
Best forms of magnet for  
lifting purposes.

possible, for it must be kept in mind that if we can get the same flux across a joint that has an area of 6 square inches as flows across another joint having an area of 12 square inches, the pull in pounds in the first case will be twice what it would be in the second case. This is because the pull is proportional to the square of the number of lines per square inch flowing.

A magnet shaped as in Fig. 36 is easily and cheaply made and by its shape protects the winding inside it.

The writer designed a set of magnets for fastening a drilling machine to the bottom or sides of an iron vessel. These magnets, which would lift from 1,000 to 1,200 pounds each, weighed 11 pounds each.

A flux of 140,000 lines is as high as it is possible to go with ordinary steel, and higher than some steels will carry. Assuming that we have steel that will carry 140,000 lines, we would have a pressure of 272 pounds per square inch. Allowing 100,000 lines per square in. in the rest of the magnetic circuit and 140,000 at the joint between the armature and field, what will be the lifting power of a magnet 9 inches in diameter?

First, assume the magnetizing coil to be one inch wide by two inches deep. (Fig. 37). The sizes must be so selected that the area of the outside of the magnet equals that inside the magnet, for as many lines pass into the armature outside the coil as pass out of it inside the coil.

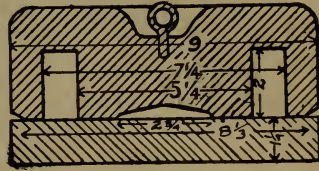

Figure 37  
Pull of iron clad magnet.

The sizes indicated do this very nearly; the area of each part is equal to the area of a circle  $5\frac{1}{4}$  inches in diameter. Table No. 13 gives this as 21.65 square inches. At 100,000 lines per square inch there would be 2,165,000 lines in the magnet.

If the surface is cut away, as indicated, so as to compel the lines to pass into the armature at a density of 140,000 lines per square inch, the area of contact will be

$$\frac{21.65 \times 10}{14} \text{ equals } 15.5 \text{ sq. in.}$$

As the pull across this surface is 272 pounds per square inch, the total pull on both poles of the magnet will be  $15.5 \times 272 \times 2$  equals 8,432 pounds.

The thickness of the armature should be such that the lines as they flow from the outside toward the center, as shown in the sketch, should never be crowded to more than 100,000 lines per square inch. In the magnet shown in Fig. 37, the point in the armature at which the lines will be most crowded will be a circle  $5\frac{1}{4}$  inches in diameter directly under the south pole of the magnet.

The surface across which the lines pass is an area equal to the circumference of a circle  $5\frac{1}{4}$  inches in diameter or 16.5 inches x the thickness of the armature. Since the area will have to be 21.65 square inches the thickness will be 21.65 divided by 16.5, or very nearly 1  $\frac{5}{16}$  inches

A magnet of this shape is used in some of the electric brakes used on some of the suburban cars.

Here the armature constitutes part of the wheel on which the car runs, and the magnet is stationary.

When current is thrown into the magnet it attracts the armature or wheel, thus tending to lock the wheel.

There is enough residual magnetism in the iron to hold the car at a standstill on an ordinary grade without the use of hand brakes.

Magnets are coming into general use for many purposes. They are used in some rolling mills for handling heavy steel ingots and for loading boiler plate on to cars, and will doubtless find a greater use as their capabilities become better known.

## QUESTIONS ON CHAPTER V.

1. What is magnetic traction?
2. How great a pressure per square inch has been produced by magnetic traction?
3. Suppose only a small number of ampere turns can be secured to attract an armature, why is it that enlarging the pole pieces and armature and therefore the air gap increases the pull?
4. Why is it that the area of contact between the armature and magnet in Fig. 33a was reduced in order to increase the magnetic traction?
5. A certain wheel on an inter-urban street car carries a weight of five tons; a pressure of one and one-half tons is required on the brake shoe in order to make this wheel slide on the rail; design as light a magnet as possible, one foot or less in diameter, that will give the pressure between magnet and car wheel when car wheel is used as the armature to make the wheel slip on the track.
6. A solenoid of the shape shown in Fig. 38 has an armature shaped like a horseshoe; how many amperes will have to flow through the solenoid in order to lift 100 pounds provided the iron core of the solenoid is two inches in diameter and there is a space of one inch between the stationary and movable iron parts of the magnetic circuit?
7. What is the best shape for a magnet for lifting purposes?

8. How many ampere turns will be required to produce a lifting power of 2,500 pounds in an iron clad magnet six inches in diameter, provided the slot for the coil is three-fourth inches wide and the surface between the armature and the magnet is 80 per cent. of the sectional area of the magnet?

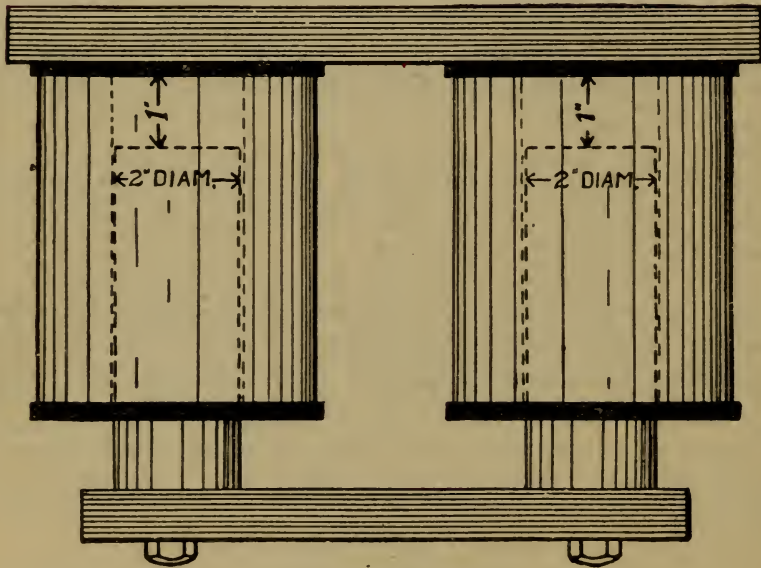

Figure 38

## CHAPTER VI.

### MAGNETIC LEAKAGE.

In dealing with the calculation of the magnetic circuit it must be clearly kept in mind that all the magnetic lines do not pass through the magnetic circuit as calculated. The air will carry lines of force and does carry a great many. The magnetic lines that are generated by the field coils and that do not pass around the magnetic circuit and through the armature are called leakage lines.

In the two figures (39 and 40) are shown the paths of the leakage lines in two styles of dynamo.

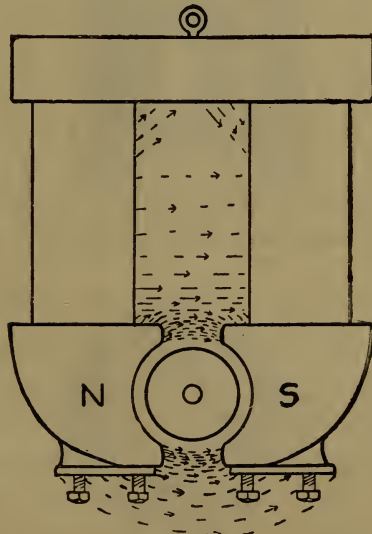

Figure 39  
Magnetic leakage in bipolar dynamo, horseshoe type.

In the Edison machines as actually made the leakage coefficient is 1.4. That is, out of 140 lines produced in the field cores only 100 pass through the armature.

In the other style of bipolar machine the leakage coefficient is less than 1.1. The reason that it is so much lower is that only a small surface of fully charged pole is exposed to the air.

In the case of the Edison dynamo (Fig. 39) the very large pole pieces N. and S. are exposed to the air and almost the full number of ampere turns tend to drive lines from N. to S. through the air gap and armature and also through the air. In Fig. 40 not 1-10 the surface in proportion is exposed for leakage.

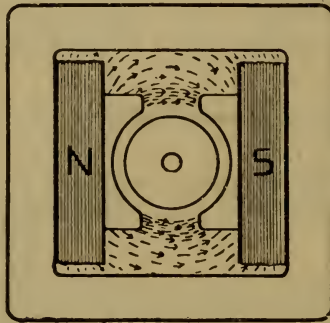

Figure 40  
Magnetic leakage in internal pole bipolar frame.

Another great advantage of the internal pole type is that what leakage there is is inside the machine, where it is not apt to draw wire nails and bits of iron dust; but in the case of the Edison dynamo the magnetic leakage will attract all the iron that comes in its neighborhood, and there is danger of pieces of iron being drawn into the armature.



## TABLE No. VIII.

Diagrams of magnetic circuits of several dynamos and their leakage coefficients.

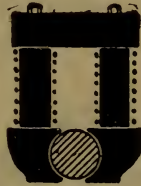

Diagram of magnetic circuit of Edison dynamo.  
Leakage coefficient 1.4.

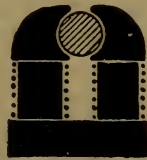

Diagram of magnetic circuit of T. H. bipolar dynamo.  
Leakage coefficient 1.3.



Diagram of magnetic circuit of Westinghouse 4-pole dynamo.  
Leakage coefficient 1.1.



Diagram of magnetic circuit of Lincoln 2-pole dynamo.  
Leakage coefficient 1.1.

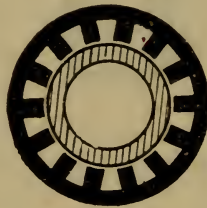

Diagram of magnetic circuit of G. E. 14-pole alternator dynamo.  
Leakage coefficient 1.25.



Diagram of magnetic circuit of Siemens & Halske dynamo,  
4-pole field inside armature. Leakage coefficient 1.08.



Diagram of magnetic circuit of Manchester type.  
Leakage coefficient 1.5.

## QUESTIONS ON CHAPTER VI.

1. What is magnetic leakage?
2. What is the relative conductivity of air and iron as used in a dynamo for magnetic lines?
3. How is it possible to design a machine so that the magnetic leakage will be reduced to a minimum?
4. Why is it that an Edison dynamo has so many more leakage lines than an internal pole machine such as shown in Fig. 36?
5. In Fig. 25 it was assumed that all the lines flowed through the iron teeth into the armature. How many lines will leak through the slots occupied by the wire?
6. How many lines will leak across the space in which the armature revolves if the armature is removed in Fig. 29?
7. Why is it that there is such a great amount of magnetic leakage and so small an amount of electric leakage in ordinary circuits?
8. Does the fact that a dynamo has great magnetic leakage impair its efficiency greatly? If so, why?
9. Name other disadvantages of magnetic leakages.
10. What are the advantages of the internal pole type of machines as compared with the horseshoe magnet type?
11. What is a coefficient of leakage?

## CHAPTER VII.

### ENERGY IN ELECTRIC CIRCUITS.

It is a well-known fact that when current flows through an electric circuit in sufficient quantity heat is developed. The incandescent lamp is the most ordinary example of this. Experience will prove that doubling the amount of current through a resistance without changing the voltage doubles the heat produced in the resistance. Also doubling the voltage tending to drive current through resistance without changing the current doubles the heat produced. This may be very easily proved by making the experiments indicated in Figs. 41, 42 and 43.



Figure 41  
Certain heat produced in lamp

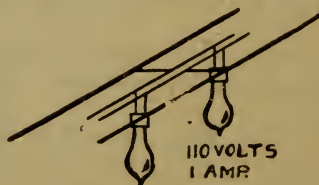

Figure 42  
Twice as much heat with same voltage and twice the current.

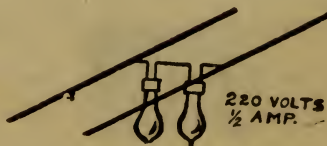

Figure 43  
Twice as much heat as Figure 37 with double voltage and same current.

It is clear that the energy in the electric circuit is proportional to the current and also to the voltage or to the product of voltage and current.

Energy in an electric current is measured in watts, and we may write watts equals amperes x volts, or

$$W \text{ equals } C \times E \text{ (8)}$$

Substituting in (8) its value from Ohm's law  $C$  equals

$$\frac{E}{R}$$

— (See Chap. I.)

We have

$$W \text{ equals } \frac{E}{R} \times E \text{ equals } \frac{E^2}{R} \text{ (9).}$$

Again substituting in (8) the value of  $E$  from Ohm's law equals  $C \times R$ .

$$W \text{ equals } C \times C \times R \text{ equals } C^2 R \text{ (10).}$$

Putting (8), (9) and (10) in words:

Watts equals amperes x volts (8).

Watts equals (volts x volts) divided by ohms (9).

Watts equals amperes x amperes x ohms (10).

746 watts equals one horse power.

These formulae should be carefully studied and thoroughly committed to memory. Suppose it is required to find how many horse power a certain motor is using from the circuit supplying the power. First measure the voltage at which current is delivered, next measure the current.

Suppose a circuit supplying power has 240 volts

and that a motor is taking 15 amperes. From formula (8) we have watts equals  $240 \times 15$  equals 3600 watts. The horse power equals the watts divided by 746, or H. P. equals  $3600$  divided by  $746$  equals 4.83.

Suppose the same current was used in a heater or a wire resistance, the resistance would be

$$R \text{ equals } \frac{E}{C} \text{ equals } \frac{240}{15} \text{ equals } 16.$$

If now formulae (8), (9) and (10) are correct, all three should give the same result in watts. We have

Amperes equal .....	15
Volts equal .....	240
Ohms equal .....	16
Watts equal .....	3600

Formula (8) is watts equals amperes x volts equals  $15 \times 240$  equals 3600.

Formula (9) is watts equals volts x volts divided by ohms equals  $\frac{240 \times 240}{16}$  equals 3600.

Formula (10) is watts equals amperes x amperes x ohms equals  $15 \times 15 \times 16$  equals 3600.

If the shunt field coil of a dynamo takes  $2\frac{1}{2}$  amperes at 200 volts, what is its resistance and how many watts is it using?

$$\text{Ohms equals } \frac{E}{C} \text{ (3) equals } \frac{200}{2.50} \text{ equals } 80.$$

Watts equals  $E \times C$  equals  $200 \times 2\frac{1}{2}$  equals 500 or about 2-3 H. P.

If a series dynamo has 10 amperes flowing through its field and the resistance of the wire is 3.6 ohms, how many watts is it using and how many volts are required for this part of the circuit?

Volts equals  $C \times R$  (2) equals  $10 \times 3.6$  equals 36.

Watts equals  $C^2 R$  equals  $10 \times 10 \times 3.6$  equals 360, or a little less than  $\frac{1}{2}$  H. P.

Suppose the current in a long distance power transmission plant is 300 amperes and that the voltage at the receiving end is 750 volts less than at the sending end, what is the resistance of the line and how many H. P. are lost due to the resistance?

$$R \text{ equals } \frac{E}{C} \text{ (3) equals } \frac{750}{300} \text{ equals } 2\frac{1}{2} \text{ ohms.}$$

Watts equals  $C \times E$  (12) equals  $300 \times 750$  equals 225,000.

H. P. equals 225,000 divided by 746 equals 301.6 H. P.

If the voltage at the sending end was 10,000, what was the proportion of power delivered to that received?

Power delivered to line, watts equals  $300 \times 10,000$ .

Power received from line, watts equals  $300 \times 9,250$ .

Ratio equals  $\frac{925}{1000}$  equals 92.5%, or efficiency of transmission line.

Why is it that high voltage is used in all the long distance power transmission plants? A study of formulae (8), (9) and (10) will answer this question.

Suppose it is desired to transmit 50 H. P. five miles. The watts will be  $50 \times 746$  equals 37,300. If this is generated at 250 volts the current will be 37,300 divided by 250 equals 149 amperes.

If the line has a resistance of  $\frac{1}{2}$  ohm, the volts lost in the line will be  $149 \times \frac{1}{2}$  equals 74.5. The efficiency of transmission will be

$$\frac{(250-74.5) \times 300}{250 \times 300} \text{ equals } \frac{175.5}{250} \text{ or about 70 per cent.}$$

That is, 30 per cent. of the power is lost in the line.

If now the same power be generated at 500 volts, the amperes will be 37,300 divided by 500 equals 74.5 amperes. The volts lost on the line will be  $\frac{1}{2} \times 74.5$  equals 37.25. The efficiency of transmission

$$\frac{(500-37.25) \times 74.5}{500 \times 74.5} \text{ equals } 92.50$$

In this case only  $7\frac{1}{2}\%$  of the power was lost. If we should repeat the calculation at 1000 volts we would see that only  $\frac{1}{4}$  of  $7\frac{1}{2}\%$  would be lost, or less than 2%. That is, 50 H. P. transmitted at 250 volts loses 30%, and at 1000 volts less than 2%.

The power lost in transmission is inversely proportional to the square of the voltage with a given line.

The use of high voltage enables a small and cheap line to transmit the same power with the same loss that a line with four times as much copper in it would transmit with



the same loss at half the voltage. A little thought will show that the line loss is proportional to the square of the distance from the generating station if equal amounts of copper are used in all the lines. Thus a line one mile long having 1000 pounds of copper will have a resistance of .85 ohms; a line two miles long having the same 1000 pounds of copper in it will have a resistance of 3.4 ohms, or four times as much. If the same current is sent over both lines there will be four times as much loss in the two-mile line as in the one-mile line. But if, at the same time that the length of the line is doubled the voltage is also doubled, 100 H. P. can be transmitted over the long line with the same loss as over the short one. Thus, with a given line loss and a given amount of copper in the line, the distance to which power can be transmitted is directly proportional to the voltage.

In calculating watts lost in an armature, it is necessary usually to find the current flowing through it and find the resistance of the armature and use these two factors to find the watts lost.

L. of C.

## QUESTIONS ON CHAPTER VII.

1. What are the three formulae representing power in an electric circuit?

2. How many watts are there in one horse power?

3. How many watts are expended in a circuit feeding a number of heaters if the current is eight amperes and the E. M. F. 500 volts?

4. How many amperes are flowing in a circuit which consumes five and one-half horse power at 110 volts; at 1,000 volts?

5. What is the resistance of a feed wire in which eight H. P. are lost when 300 amperes are being carried by the line?

6. What H. P. is developed by a dynamo which delivers 400 amperes at 250 volts?

7. What is the per cent. drop in a feed wire in which five H. P. are lost when 250 amperes are flowing, and the dynamo producing the current has an E. M. F. of 300 volts?

8. Is it possible to determine the resistance of the armature in question 6 from the data given in that question? If so what is the resistance?

9. How much current is used on a lamp that requires 64 watts on a 110 volt circuit?

10. How many amperes equal one H. P. on a 110 volt circuit? On a 220 volt circuit? On a 500 volt circuit? On a 1,000 volt circuit? On a 10,000 volt circuit?

11. How many amperes are there in a kilowatt or in 1,000 watts or in a K. W. in circuits of each of the voltages specified in question 10?

12. Why is it that the Edison three-wire system is economical of copper?

13. Would a five-wire system on the same plan be more or less economical? Why?

14. Why is high voltage used for distributing power to great distances?

15. Would it be practicable to transmit 100 H. P. over a line having three and one-half tons of copper in it to a point five miles away if 250 volts were used?

16. Would it be practicable with 500 volts; with 1,000 volts; with 20,000 volts?

17. Why is it that that with the same cost for copper the power loss increases as the square of the distance from the power station?

18. In what ratio does the loss of power decrease with increasing voltage, cost for copper remaining the same?

19. What is the ratio of distance to which power may be transmitted and voltage of supply with constant cost for copper and constant line loss?

20. What will be the cost for copper at .15 per pound for a line that will transmit power for 500—55 watt lamps at 250 volts on a three-wire system perfectly balanced  $\frac{1}{2}$  mile from dynamo if current is supplied to lamps at 110 volts?

21. Suppose a dynamo is supplying a power circuit at 125 volts and it is desired to light 300—55 watt lamps at a pressure of 110 volts 2,500 feet away. Two methods can be used for lighting these lamps; a large wire can be run from the dynamo to the lamps, in which there will be a drop of 15 volts. A second method is to drive a 650-volt dynamo from the same engine that drives the 125-volt dynamo, operate a motor on the 650-volt current and drive a second dynamo working at 110 volts to light the lamps. If copper costs .15 per pound, and three extra electric machines cost \$1,500, which will be the cheaper installation?

22. If one horse power is lost in 1,000 feet of No. 0000 wire with a drop of 35 volts, what current is the feeder carrying?

23. Why is it that in calculating the number of watts lost in an armature that formula No. 14 is usually employed?

## CHAPTER VIII.

### CALCULATION OF MAGNET COILS.

As shown in the chapter on the magnetic circuit it is possible to find how many ampere turns are required to force a given magnetic flux over a given magnetic circuit. After it is discovered in this way how many ampere turns each coil should produce, it is necessary to select the size of wire and determine the amount that should be used to produce the desired result.

The magnetizing power of any coil is measured in ampere turns, or the product of the amperes which flows through the wire, multiplied by the number of times it circulates around the core. The meaning of the term is almost self-evident.

A very peculiar fact becomes apparent upon examining the number of ampere turns produced by a given coil when exposed to the same voltage. Take, for instance, a coil wound around an iron core  $3\frac{1}{2}$  inches in diameter; let the thickness of the magnetizing coil be such that the average diameter of the coil will be  $3\frac{7}{8}$  inches, so that the average length will be one foot. If this coil is wound with one pound of No. 16 wire it will have, as shown by Table 1, 124 turns.

The resistance of such a coil will be .515 of an ohm. If such a coil is exposed to a pressure of 50 volts, 97.1 amperes will flow through it, and the ampere turns produced by the coil will be  $97.1 \times 124$ , or 12,040.

If twice as much wire be used on this coil, the ampere turns will not be twice as great as might be expected, but will remain the same. The only difference will be that instead of 97.1 amperes flowing through the coil, only half of this, or 48.55 amperes will flow.

It will be seen that doubling the amount of wire on a coil has doubled the number of turns, but also doubled the resistance of the coil so as to reduce the current to one-half.

The product of double the number of turns multiplied by half the number of amperes which we have in the second coil produces the same number of ampere turns as were produced by the first coil. Increasing the weight of the coil then simply decrease the amount of current required to produce a given number of ampere turns.

To produce a greater number of ampere turns in this same coil, it will be necessary to wind the coil with larger wire, or to increase the voltage applied to the terminals of the coil. By using a wire of twice the sectional area of No. 16, double the number of ampere turns will be produced, or if the average length of the coil instead of being one foot is two feet, a wire of double the sectional area of No. 16 will be required to produce 12,040 ampere turns at 50 volts. If at the same time that the average length of the turn was increased from one foot to two feet, the voltage was raised from 50 volts to 100 volts, No. 16 wire would still continue to produce 12,040 ampere turns.

Putting these considerations into the form of an equation we have:

$$A \text{ equals } \frac{11\frac{1}{2} \times A \times T \times L}{E}$$

in which A is area of the wire in circular mils or is the square of the diameter in thousandths of an inch.

A. T. equals ampere turns, L equals average length of one turn of the magnetizing coil in feet, E equals pressure in volts.

Take the Edison machine shown in Fig. 28. Suppose it is a 220-volt motor. It is found that 11,074 ampere turns should be produced by each coil to force the desired flux around the circuit.

Let us assume that the coil will be two inches thick. It is not good practice to make them much thicker than this, because if they are the heat cannot get away from the inner layers out to the air through the outer layers. This makes the average length of the turn the circumference of a circle 10 inches in diameter, or 31.41 inches long, or 2.62 feet long.

E equals 110 volts, for the motor works on a 220-volt circuit and is provided with two coils connected in series.

$$A \text{ equals } \frac{11.5 \times 11074 \times 2.62}{110} \text{ equals } 3040$$

Examination of Table I shows that this is between No. 15 and No. 16 wire, and we will select No. 15 as being the size required. If it is desired to know just what number of a. t. No. 15 will produce, find how many turns one pound will make, or 101.63 divided by 2.62, or 38.8 turns per pound.

A one-pound coil will have a resistance of .32 ohms per pound, and a coil made of a single pound will allow 110 divided by .32 or 344 amperes to pass. The ampere turns of this size will then equal 38.8 x 344 equals 13,347 ampere turns.

It should be carefully kept in mind that the amount of wire on a coil simply determines whether it shall run cool or hot; the size of the wire determines the number of ampere turns.

The formula is arranged on the assumption that the average temperature of the magnetizing coil is 125 degrees Fahrenheit. This assumption gives a larger wire than would be necessary if the coil operated at a lower temperature, because the resistance of copper wire increases .21 of one per cent. for each degree Fahrenheit rise in temperature, and if the magnetizing coil could operate at an average temperature of 75 degrees Fahrenheit instead of 125 degrees, the resistance of the coil would be  $10\frac{1}{2}$  per cent. less, and its magnetizing power  $10\frac{1}{2}$  per cent. greater.

If, however, the average operating temperature of the coil is above 125 degrees Fahrenheit, the size of the wire will be too small rather than too large, because the resistance of the wire composing the magnetizing coil will be greater than that assumed in the formula.

Wire enough should be put on the coil so that the watts lost will not be over .8 per square inch, and much more satisfactory results will be obtained if enough are used so that only .5 watts will have to be radiated per square inch.

In the coil for the Edison dynamo the radiating surface is 10 inches x the circumference of a circle 12 inches in diameter, or  $10 \times 37.64$  equals 376.4 sq. in. While a large part of the heat radiated from the coil will escape from the outside, almost as much will be radiated from the ends of the coil and into the iron core inside. The iron core will conduct the heat to the heavy pole piece and yoke, where it is quickly radiated.



It is safe to allow three-fourths as much radiating surface for the rest of the coil as it has direct radiating surface, so the total radiating surface is  $376 + \frac{3}{4}(376)$  equals 658 square inches. At  $\frac{1}{2}$  watt per square inch we have wasted in this coil 329 watts, and at 110 volts this means a current of 329 divided by 110 equals 3.0 amperes.

We have seen that if the coil has only one pound of wire 344 amperes will flow. If only three amperes are wanted, we will have to make the coil weigh 344 divided by 3 equals 115 pounds. The final result as to the winding for the magnetizing coil for the Edison dynamo is then 115 pounds of No. 15 B. & S. wire.

The next question is, will the space allowed for the winding take so much wire as this?

The cross section of the coil was 2 inches x 10 inches and the average length of each turn was 2.62 feet. The number of turns in each layer would be 10 inches divided by .065, for No. 15 wire is .057 under the insulation and will be about .065 over the insulation if single cotton-covered wire be used.

10 divided by .065 equals 153 turns per layer.

The number of layers will be 2 divided by .065 equals 31.

The number of feet on the coil will be  $153 \times 31 \times 2.62$  equals 12,427 feet.

Table No. 1 shows that single cotton-covered magnet wire weighs 10.13 pounds per 1000 feet, and 12,427 feet will weigh  $12.43 \times 10.13$  equals 126 pounds. We can get in 126 pounds of wire in the space that 115 pounds should be put in.

What sized wire and how much should be used to wind the ironclad dynamo shown in Fig. 31. Here the ampere turns required are 2791; the coil was 3 inches wide x 2 inches thick. The average length of this coil may be found from Fig. 44. The average length of the turn is 6 plus  $2\frac{1}{2}$  plus 6 plus  $2\frac{1}{2}$  plus

$$(3.1416 \times 5)$$

or the circumference of a circle 5 inches in diameter equals 32.7 inches equals 2.72 feet. Suppose this is to be a 500-volt motor, then each of the two coils will be exposed to 250

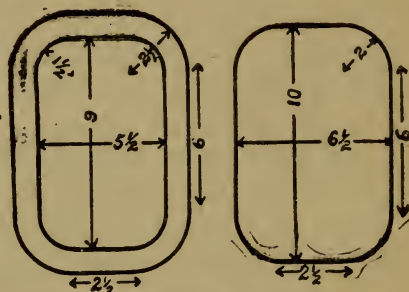

Figure No. 44  
Dimensions of magnetizing coil—  
average length of turn.

Substituting in the formula, we have:

$$A \text{ equals } \frac{11\frac{1}{2} \times 2789 \times 272}{250} \text{ equals } 337.8$$

or a little larger than No. 25.

No. 24 will have to be used.

No. 24 or .020 wire has 819.2 feet per pound, and 819.2 divided by 2.72 equals 301 turns per pound. Also it has 21 ohms per pound and a one-pound coil allows 250 divided by 21 equals 12 amperes to pass;  $12 \times 301$  equals the ampere turns of No. 24 wire equals 3612.

The coils for this motor are wound on forms and slipped over the pole piece. This allows all the outside and both sides to radiate heat, and we may allow one-half the inside surface of the coil as a radiating surface.

Radiating surface equals  $(32.7 \times 2 \times 2) + (39 \times 3) + \frac{1}{2}(26.5 \times 3)$  equals 288 square inches. At  $\frac{1}{2}$  watt per square inch the current will be 144 divided by 250 equals .58 amperes.

If a one-pound coil passes 12 amperes, the coil must weigh 12 divided by .58 equals 20.6 pounds to cut the current down to .58 amperes.

The winding for the magnetizing coil for the motor in Fig. 25 for 500 volts is 20.6 pounds of No. 24 wire.

It is clear that in a coil exposed to a constant potential the size of the wire and not the amount of wire or number of turns is what determines the magnetizing power.

In a constant current dynamo, such as one used for arc lighting, the number of turns determines the magnetizing power, and the size of the wire simply determines the amount of heating or the energy wasted in the coil.

In a coil using constant current it is only necessary to divide the number of ampere turns required by the number of amperes. This gives the turns required. Then select a wire of such size that the coil will not get too warm.

The same rule should be followed in calculating the size of wire required for the series coil of a compound wound dynamo. It should be kept in mind that the heating of a shunt coil on a constant voltage raises the resistance and prevents more current from flowing, thus tending to prevent the coil from over-heating.

In the series coil the reverse is true, for the heating of the coil makes the resistance higher and so increases the heating with a given current.

## QUESTIONS FOR CHAPTER VIII.

1. In calculating the ampere turns for a magnetizing coil of any given size of wire, what is the first thing necessary to know about the dimensions of the coil?

2. Describe how the number of ampere turns that will be produced by a coil of given dimensions and size of wire may be determined.

3. How many ampere turns will be produced by a coil whose average diameter is 10 inches, size of wire No. 20, coil exposed to an electro-motive force of 110 volts?

4. What size of wire will be required to produce the same number of ampere turns as in preceding question at  $27\frac{1}{2}$  volts?

5. How many ampere turns will be produced in a coil having an average length of turn of 4 inches if the voltage used is 110 and the wire used is No. 20?

6. Why is it advisable when only a small amount of electrical energy is available for the purpose of magnetizing a small horse-shoe magnet to make the coil long and thin?

7. Why are such large magnet cores used in commercial dynamos?

8. When a coil is exposed to a constant electro-motive force why does the size of the wire and not the amount of the wire in the coil determine the ampere turns produced by the coil?

9. Is there any reason for using a coil of considerable weight rather than using one weighing only a few pounds?

10. What size of wire will be required on the motor shown in Fig. 31 for a six-volt plating dynamo; for 110, 220, and 500-volt motors?

11. What weight of wire will be used in the coils calculated in the preceding question if  $\frac{1}{2}$  of a watt be radiated for one square inch of the surface of the coil?

12. How many watts per square inch is it safe to allow the coil to radiate?

13. Why is it not advisable to use a coil more than two inches in thickness?

14. How much does the resistance of copper wire increase on account of the increase of the temperature?

15. How is it possible to determine the number of pounds of wire that will be required in a coil to reduce the current consumed to a given amount?

16. Calculate the size and weight of the wire required for a 250-volt motor of the dimensions calculated in answer to question 19, chapter V.

17. Calculate the size of wire and weight required for the magnetizing coils in Fig. 31, provided they radiate  $\frac{1}{2}$  watt per square inch when used as a 250-volt dynamo.

18. How are the ampere turns for a series coil calculated?

19. What is the effect on the power wasted in a coil of the raise in temperature in a coil exposed to a constant voltage?

20. What is the effect in a coil through which a constant current flows?

## CHAPTER IX.

### WINDING ELECTRIC MACHINERY FOR DIFFERENT E. M. Fs.

It was explained in Chapter IV that E. M. F. is produced by a wire cutting lines of force, and it was also stated that where magnetic lines are cut at the rate of 100,000,000 per second, one volt is produced. Fig. 45 shows the cutting of the lines of force in a Gramme ring armature and also the path of the lines. Fig. 46 shows the cutting in the internal bi-polar machine shown in Fig. 31.

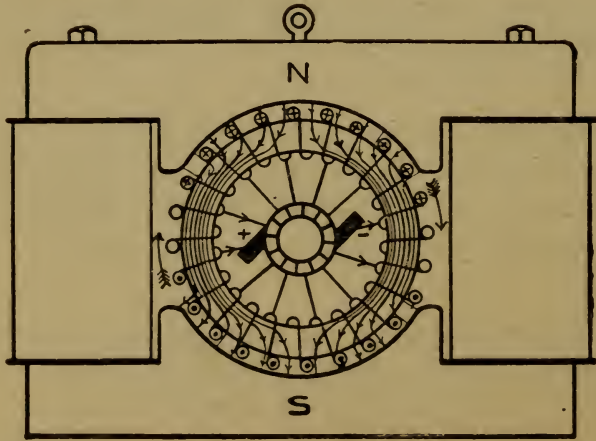

Figure 45  
Production of E. M. F. in Gramme ring armature.

In the gramme ring armature the lines cross the air gap and pass around the ring from the N. pole to the S. pole. When the armature revolves, there is a constant movement of the magnetism in the armature. A few of the magnetic lines leak across the space inside the ring, as shown in the sketch.

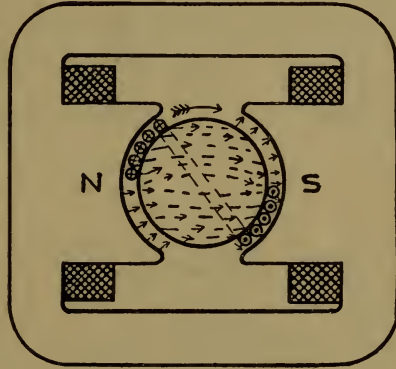

Figure 46  
Production of E. M. F. in drum armature.

By applying the rule on page 47, we see that the current tends to flow toward the observer in the wires in the air gap in the lower part of the armature.

The same rule shows that the current flows away from the observer in the upper part of the armature. A little thought will show that if the winding on the ring is a continual spiral, these two currents will meet each other at points marked  $+$  and  $-$  about half way between the poles.

If the spiral be connected at regular intervals to the bars of a commutator and two brushes touch this commutator at points on a horizontal line, there will be an E. M. F. between these two brushes equal to the sum of the E. M. F.'s produced in all the wires under one pole.

Suppose the armature revolves 1200 turns per minute; this will be 1200 divided by 60 equals 20 revolutions per second. Also suppose there are 1,000,000 lines of force flowing from the N. pole into the ring through the ring into the S. pole. Each wire on the armature will cut 20 times per second the 1,000,000 lines in the upper air gap, and therefore each wire cuts  $20 \times 1,000,000$  equals 20,000,000 lines per second.

Since it requires cutting at the rate of 100,000,000 per second to produce one volt, each wire on the armature produces

$$\frac{20,000,000}{100,000,000} \text{ equals } 1/5$$

of a volt in passing through the upper air gap. The same wire produces the same voltage in the opposite direction in its passage through the lower air gap, but the two halves of the armature are in parallel. The E. M. F. produced may be illustrated by the diagram in Fig. 47.



Figure 47

Production of E. M. F. in an armature illustrated by two groups of batteries placed in parallel.



In Fig. 47 if each cell produces two volts, the whole 12 cells produce only 12 volts, but the capacity for delivering current is doubled. The same thing is true of the dynamo armature. There are always two voltages produced which are placed in parallel. This fact makes the carrying capacity of an armature for current always equal to twice that of a single wire of the size the armature is wound with.

If there are 550 wires or 550 turns on the armature in Fig. 41, the E. M. F. produced will be 550 times that pro-

duce in one wire, or  $\frac{550}{5}$  equals 110, or, in the form of an

equation:

$$\text{E. M. F. equals } \frac{1,000,000 \times 550 \times 20}{100,000,000} \text{ equals 110}$$

In symbols this becomes:

$$\text{E. M. F. equals } \frac{N \times T \times S}{100,000,000} \quad (11)$$

Transforming (11) to get the other quantities:

$$N \text{ equals } \frac{\text{E. M. F.} \times 100,000,000}{T \times S} \quad (12)$$

$$T \text{ equals } \frac{\text{E. M. F.} \times 100,000,000}{N \times S} \quad (13)$$

$$S \text{ equals } \frac{\text{E. M. F.} \times 100,000,000}{N \times T} \quad (14)$$

Where  $N$  equals total number of lines flowing across one air gap,  $T$  equals total number of wires on the armature that cut lines of force, and  $S$  equals number of revolutions per second.

The turns on the inside of the Gramme ring do not cut any lines and so produce no E. M. F.

In the case of the drum armature, however, the one side of a turn is in one air gap and the other side is in the other air gap. Therefore it is only necessary to have half as many turns in a drum armature to get the same E. M. F. as are required in a Gramme ring. At first sight it would seem that the Gramme ring would require much more wire for the same E. M. F. than the drum armature, but each turn is much shorter in the Gramme ring than in the drum armature.

A very important practical advantage that the Gramme ring possesses is that the wires do not cross each other at the end of the armature. If anything is the matter with one coil in a Gramme ring it can be removed without touching any of the other coils. This is not the case with a drum armature, for coils cross each other and it may be necessary to take off all the coils in order to get down to the one that is damaged.

It is easy to see that with a given iron frame and armature core the only thing necessary to do to make it develop different voltages is to put different numbers of turns on the armature. If it was desired in Fig. 45 to produce 220 volts, it would be necessary to wind on 1100 turns of wire instead of 550.

Suppose there is a flux of 1,200,000 lines in the core shown in Fig. 46, that there are 40 coils on the armature, that the machine runs 1,500 revolutions per minute. How many turns will it be necessary to use for 500 volts, for 220 volts, and for 110 volts?

Substituting in (13)

$$T \text{ equals } \frac{500 \times 100,000,000}{1,200,000 \times 25}$$

Solving this equation,

$$T \text{ equals } \frac{500 \times 100,000,000}{1,200,000 \times 25} \text{ equals } 1667$$

This is the number of active conductors on a Gramme ring or drum armature. This will be half the number of turns on a drum armature. The number of turns will be 1667 divided by 2 equals 834, and since there are 40 coils, each coil will contain 834 divided by 40 equals 21 wires. Each turn in such a coil contains two wires that generate E. M. F.

The fundamental fact on which the action of the dynamo depends was illustrated in Fig. 20, and it is excellent practice to determine from the direction of rotation of an armature and from the polarity of the magnet in any actual dynamo the direction in which the current is running on the armature.

It is easy to determine the number of lines of force that are flowing across any dynamo armature.

Suppose an Edison dynamo has 60 coils having two turns each, and that it generates without any load 230 volts at a speed of 1200 revolutions per minute. What is the flux across the armature?

In this case

S equals 1200 divided by 60 equals 20.

T equals  $60 \times 2 \times 2$  equals 240.

Substituting in (12),

$$N \text{ equals } \frac{230 \times 100,000,000}{240 \times 20} \text{ equals } 4,792,000$$

In practice the only difference in dynamos designed for the same output at different voltages is the difference in the number of turns of wire on the armature.

Suppose the dynamo is designed for 500 volts with a certain number of turns on the armature; for 250 or 220 volts only half this number is used and for 125 or 110 volts only one-fourth as many are used.

Another way in which the voltage produced in a dynamo may be considered is the change in number of lines of force enclosed or embraced by a coil.

There will be an E. M. F. generated in a coil proportional to the rate of change in the number of lines of force embraced by the coil.

If lines of force are put into or taken out of a coil at the rate of 100,000,000 per second, one volt is produced. The E. M. F. produced by such a change in the number of

lines embraced by a coil may be determined by Lenz law. According to Lenz law the current produced in a closed coil by a change in the number of lines of force is always in such direction as to oppose by its own magnetic action the change in number of lines enclosed.

The result is, that when a S. pole is caused to approach a closed coil the current in it will flow in such a direction as to produce a S. pole in the coil, opposing the approaching S. pole, and, when the S. pole is being withdrawn, the current will flow so as to produce a N. pole in the coil opposing the approaching N. pole.

In the first case the approaching pole is repelled, and in the second, the receding pole is attracted; therefore power is required both to cause the pole to approach and to recede.

## QUESTIONS ON CHAPTER IX.

1. How many lines of force is it necessary for a wire to cut per second in order to produce one volt?

2. Explain the production of electro-motive force in a gramme ring armature.

3. What is the office of a commutator on a direct current machine?

4. Why is the resistance of an armature never more than one-fourth that of the wire with which the armature is wound?

5. How many volts will be produced in a two-pole armature drum wound having 30 slots in the armature if the armature is wound with 30 bobbins of 10 turns each and the flux across the armature is 1,000,000 lines and the speed is 1,200 revolutions per minute? How fast would the above armature run as a motor on a 150-volt circuit?

6. Give from memory the four formulae expressing the relation between the E. M. F., magnetic flux, the speed and the number of turns.

7. A bi-polar dynamo runs 1,140 revolutions per minute and produces 114 volts; there are 36 slots in the armature, each bobbin has six turns of wire. What is the magnetic flux across the armature?

About .050 insulation should be used between the wire and iron.

8. A bi-polar motor on a 120-volt circuit is desired to run 1,100 revolutions per minute; there are 48 slots in the armature and the flux is 2,100,000 lines. Each slot in the armature is  $\frac{1}{4}$  inch wide and  $\frac{5}{8}$  of an inch deep. How many turns will be required in each bobbin and what will be the resistance of the armature?

9. What is it necessary to change about a motor in order to make it operate on a circuit of double its voltage?

10. What is true of the number of turns of wire required to produce the same electro-motive force on a gramme ring and a drum armature?

11. What advantage does the method of winding used on a gramme ring armature possess?

12. A bi-polar gramme ring armature is designed to run at 1,500 revolutions on 250-volt circuit; there are 56 sections on the armature, each with two turns. What would be the section required in the pole pieces of this dynamo if a flux of 40,000 lines per square inch is used?

13. Why will the resistance of an armature be quadrupled if it is rewound to run at half its original speed?

## CHAPTER X.

### COUNTER ELECTRO-MOTIVE FORCE.

Whenever an armature is revolved in an excited field, E. M. F. is produced, whatever be the cause of the rotation. The armature may be revolved by a belt from an engine, or it may be revolved by a motor directly connected to it, or it may be revolved by a current flowing through it in such a direction that it becomes a motor.

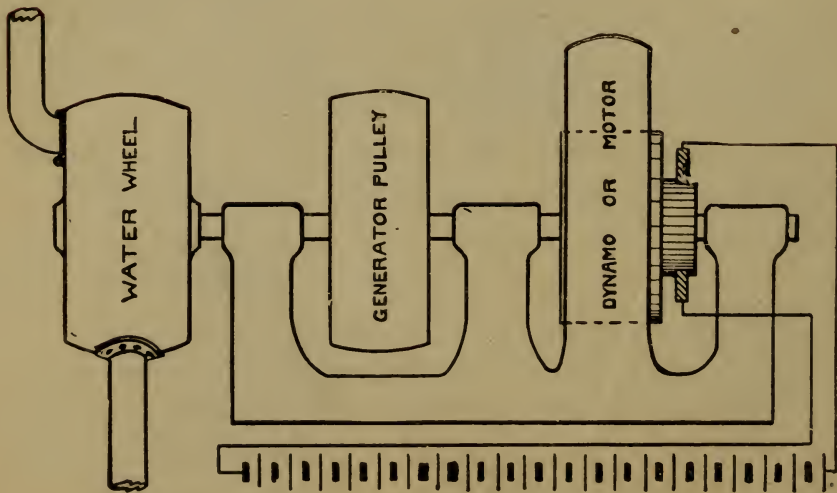

Figure 48

Illustration of the identity of counter and primary E. M. F.



In the first two cases the E. M. F. produced may be measured and used to produce current in an outside circuit if desired. In the last case, however, the E. M. F. appears as an E. M. F. opposing the E. M. F. of the current that drives current through the motor. This E. M. F. is called counter E. M. F., because it acts counter to the primary or principal E. M. F. That this counter E. M. F. really exists may be made clear by a study of Fig. 48.

In Fig. 48 the source of power is a turbine water wheel having a capacity of 100 H. P. This drives a shaft on which is a pulley that drives a 175 H. P. dynamo for street railroad work. Connected to the shaft is a 75 H. P. dynamo that charges a storage battery. The average load on the street railway generator is 100 H. P., but it varies from 25 H. P. at the lowest to 175 H. P. at the highest. If the main dynamo is taking at any time 75 H. P., the turbine wheel will rise in speed a little and so raise the speed of the motor dynamo a few revolutions until the extra 25 H. P. is used in producing current that charges the storage battery.

If, now, two or three cars all start at the same time, the load on the main dynamo may become 150 H. P. This will cause the speed of the turbine wheel to drop a little until the voltage of the dynamo is a little less than that of the storage battery, when current will flow from the battery into the armature of the machine, which is now a motor until it is developing 50 H. P.

The electro-motive force of the dynamo now appears as counter E. M. F., which tends to prevent the storage battery current from flowing through it.

The scheme here illustrated is practical, and a variation in speed of 40 or 50 revolutions in 1200 would change the

machine from a dynamo charging the storage battery at the rate of 75 H. P. to a motor taking power from the battery and delivering 75 mechanical H. P.

It is now easily seen why a current in magnet of start. box is so nearly constant in speed.

The resistance of the armature is very low, so that with full load current only a few volts are lost due to resistance, and the force that prevents a great rush of current through the armature is the Counter E. M. F. of the armature. Consider equation (14):

$$S \text{ equals } \frac{E. M. F. \times 100,000,000}{N \times T}$$

This indicates that the speed depends on the E. M. F. and will change in the same ratio that it does, for N, the total flux through the armature, will remain constant as long as the voltage on the exciting coils does not change, and T, the number of turns on the armature cannot be changed after the armature is wound.

The counter E. M. F. plus the volts lost in the armature must always be equal to the applied E. M. F., and if the resistance of the armature is low, so that only two or three volts are lost in it at the heaviest load, the counter E. M. F. must remain constant, and if the counter E. M. F. is constant, the speed must remain the same.

Looking at this in another way, the voltage forcing current through the armature is the difference between the applied and the counter E. M. F.

If a heavy load is thrown on a motor that requires a heavy current, the first effect will be to reduce the speed. Reducing the speed lowers the counter E. M. F. and this causes a greater E. M. F. to force current through the armature.

If the applied E. M. F. is 110 volts and the resistance is .01 ohm, and the current required to run the armature without any load on it is 6 amperes, the counter E. M. F. is 109.94 volts. If full load is thrown on, which may be 100 amperes, the loss of voltage in the armature is one volt and the counter E. M. F. is 109 volts. These figures are about what obtain in practice. Thus by a change of less than 1% in speed the motor has taken its full load current.

In a shunt wound motor the field is constant and the speed is consequently almost perfectly constant. In a series motor, however, the current that supplies the armature and fields is the same, and anything that alters the current in the armature alters the current in the field and changes the flux through the armature.

Figs. 49 and 50 show a diagram of the winding of a shunt and series motor respectively.

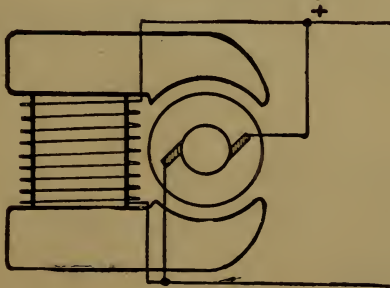

Figure 49  
Diagram of connections of shunt motor.

In the shunt motor the amount of current passing through the armature does not directly affect the amount of magnetic flux which passes through the armature. In the series motor, however, the amount of current passing through the field coil is directly proportional to the load on the motor. Since in a general way the amount of magnetic flux through the armature is proportional to the magnetizing power of the field coil, the heavier the load on the motor the greater the magnetic flux, and consequently from equation (14) the speed drops on account of greater magnetic flux.

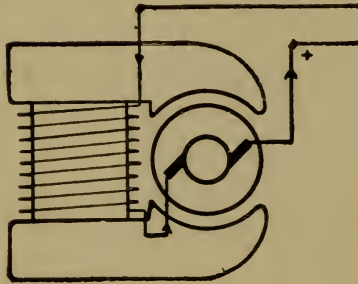

Figure 50  
Diagram of connections of series motor.

Another thing which causes the speed to drop is the voltage lost in the resistance of the field coil and armature. Due to these two causes the speed of the series motor is exceedingly variable, being high when the load is light and the magnetic flux is small, and low when the load is heavy and the magnetic flux is great.

Equation (14) put in another way says that the product of the speed and the magnetic flux must always be a constant quantity as long as the E. M. F. of supply does not change. Consequently, when one of these two quantities (speed and magnetic flux) is large, the other must be small.

When constant current is supplied to a series motor the speed of the armature will tend to become very high and means must be provided for either weakening the field or rocking the brushes so as to prevent too great a rise in the speed of the armature.

The old Baxter arc motors used the first of these methods of controlling the speed, and the Brush arc motors used the second.

The transmission of power by constant current machinery has been, however, almost entirely abandoned and constant current arc dynamos are not nearly so much used as formerly. The constant potential system having taken its place very largely, even for arc lighting.

## QUESTIONS ON CHAPTER X.

1. What is counter electro-motive force?
2. Is there any difference between the counter electro-motive force produced in a motor and the E. M. F. produced in a dynamo?
3. Why will 110 volts force only a few amperes through an armature when it is running having a resistance of 1-100 of an ohm?
4. How may the flux through a motor armature be measured by the speed of the armature?
5. A bi-polar motor armature has 66 slots; each coil has three wires; the flux through the armature is 3,600,000 lines. What will be the speed of the armature on 220 volts?
6. If the speed of the armature should be 1,050 revolutions, what would the flux be?
7. Why does the speed of a motor increase as the field coils get warm?
8. Give another instance beside that in the text of the identity of ordinary and counter electro-motive force.
9. What makes the shunt motor constant in speed, even under greatly varying loads?
10. Why does the speed in a large armature change less with change of load than in a small armature?
11. Why does rocking the brushes to an extreme backward position raise the speed of a motor?

12. A two-horse power armature has a resistance of 8-100 of an ohm; it is designed to run on 80 volts; one ampere is required to run it at no load; at the heaviest load it is designed to take 30 amperes. What would be the drop of speed in per cent.?

13. Why does the speed of a series motor vary so greatly with the load?

14. Why does the speed of the series motor change so much less with the load after the iron becomes saturated?

15. Why is the speed of a 500-volt shunt motor with unsaturated magnetic circuit almost as high when running on 110 volts as on 500 volts?

16. How will the speed of a compound wound motor vary?

17. As long as the magnetic circuit is unsaturated, why is the torque of a series motor proportional to the square of the current?

18. To what is the torque of a shunt motor proportional?

19. Why does the speed of a series motor tend to become excessively high?

20. How is the speed of constant current motors governed?

## CHAPTER XI.

### HYSTeresIS AND EDDY CURRENTS.

When iron is magnetized it tends to retain its magnetism, and when the direction of the magnetization is reversed power is required to affect this reversal.

Hysteresis may be called molecular friction caused by a reversal in position of the minute molecular magnets of which the iron is supposed to be constituted. If the core of an electro-magnet should be composed of hard steel filings and the direction of current through the magnetizing coil should be reversed, it is clear that there would be an effort on the part of the steel filings to twist around end for end and in doing so there would be more or less friction. Something of this same sort takes place when the direction of magnetization in a piece of iron takes place. It is easy to see that the direction of magnetization in a bi-polar motor armature changes twice every revolution.

An examination of Fig. 31 will show that if the left-hand pole be a north pole the magnetic lines will flow through the bottom of the teeth on the left-hand side of the armature from the top of the teeth to the bottom, and on the right-hand side of the armature from the bottom of the teeth to the top, but when the armature has made a half revolution the direction of the magnetic lines will be reversed in any particular tooth.



Table No. 9 gives the loss in watts per cubic foot at a speed of 1,200 revolutions per minute in a bi-polar field with various magnetic fluxes per square inch. This table is for good soft wrought iron and the hysteresis loss in the iron of which ordinary armatures are made, is probably higher than that given in the table.

TABLE No. IX.

## HYSTERESIS IN SOFT IRON.

Lines per sq. in	Watts wasted per cu. ft. at 1200 revolutions per minute in two-pole dynamo.
25,000	78
30,000	108
35,000	130
40,000	155
45,000	182
50,000	216
55,000	238
60,000	275
65,000	314
70,000	348
75,000	395
80,000	431
85,000	472
90,000	512
95,000	564
100,000	620
105,000	670
110,000	780
115,000	964
120,000	1124

It will be noted that in a four-pole field the direction of magnetization is reversed twice in every revolution, and if the armature in a four-pole machine runs at the same speed that it does in a two-pole, the loss by hysteresis will be twice as great with the four-pole machine as with the two-pole.

### EDDY OR FOUCAULT CURRENTS.

It is clear that there is the same tendency to produce current in the iron part of the armature due to the cutting of the magnetic lines as there is in the copper wire which is wound on its surface. If in Fig. 31 the iron core was solid, there would be a very large current circulating in the iron core in the same direction as that which flows through the wires in the air gap. Such a current as this would be entirely useless and, worse still, would heat the armature core very hot; consequently, the armature, instead of being solid, is built up of thin sheet iron discs.

These discs carry the magnetic lines without difficulty and an armature built up of these discs has the same magnetic properties as a solid wrought iron armature would have.

Fig. 51 shows the direction in which the currents tend to circulate around the armature, and shows how these currents are prevented from flowing by the insulation between the discs.

The discs in Fig. 51 may be insulated with paper, but in practice it is found that the thin coating of oxide on the outside of each disc is enough to accomplish the same purpose and produces an armature which will always remain as solid as when first put up. The use of paper between the discs is dangerous, because in time the paper charrs and crumbles to pieces, leaving the discs loose. The best way to treat the discs is to give them a thin coating of linseed oil; this forms a surface having the same insulating properties as paper, and the heat to which the armature is subjected will not affect it. In practice the discs for armatures run from ten to twenty-five thousandths of an inch in thickness. Even in the thinnest disc there are small eddy currents circulating which take power to produce and which heat the armature core. The loss by eddy currents is proportional to the square of the speed at which the armature is run, because at double speed, other things being equal, the E. M. F. is twice as great, and this double E. M. F. produces double current.

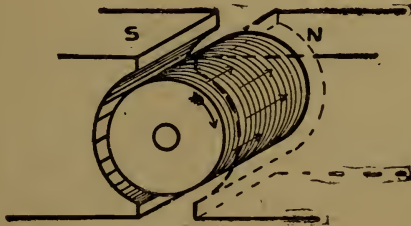

Figure 51  
Circulation of eddy currents  
stopped by lamination of the iron.

Formula 8 shows that the loss in watts with double volts and double current is four times as great as with the given voltage. It is because of the loss by eddy currents that would occur with solid pole pieces that pole pieces are laminated. A consideration of the way in which E. M. F. is produced shows that when the number of lines of force enclosed by circuit is changed there is an E. M. F. produced which tends to send current around the circuit in such a direction as to oppose the change.

When an ironclad armature with a short air gap is revolved the magnetic lines flow from the pole piece into the armature in tufts or bunches. These bunches of lines pass across the pole piece with the motion of the armature and set up currents in the solid pole piece. It is possible by the use of a long air gap to cause the lines to flow from the pole piece uniformly. But with short air gaps it is necessary to laminate the pole piece in order to get rid of eddy currents. (See Fig. 33).

## QUESTIONS ON CHAPTER XI.

1. What is hysteresis?
2. What would be the difference in passing an alternating current and a direct current around an iron core as far as hysteresis is concerned?
3. Why is the hysteresis in a four-pole motor twice as great as in a two-pole?
4. Why is there hysteresis in a revolving armature?
5. What are eddy currents?
6. In what direction would the eddy currents tend to flow in the drum armature shown in Fig. 46?
7. Why is the iron in an armature laminated?
8. Why are cables used on surface wound armatures instead of solid wires?
9. Why does the pole piece of a motor get warm if an iron clad armature is used with too short an air gap?
10. Why will the heating in such a case be much greater with steel pole pieces than with cast iron?
11. What will be the loss from the eddy current that flows clear around the armature in Fig. 31 if the flux through the armature is 1,200,000 lines, the speed of the armature is 1,200 revolutions per minute, the resistance of the armature between end plates 1-10 of an ohm and the end plates are so large as to have a negligible resistance?

12. Is there any difference in their nature between eddy currents and the useful current produced by an armature?

13. Why was paper formerly used between armature discs?

14. Why has this practice been abandoned?

15. In what way do the watts lost from eddy currents vary with the speed?

## CHAPTER XII.

### ARMATURE REACTION.

When a dynamo produces current these currents flow around the armature in such a direction as to magnetize the armature at right angles to the main field magnets. A consideration of Fig. 52 shows this, and if the direction of circulation of current in Figs. 45 and 46 be worked out, the result will be the same.

The position of the brushes on the commutator determines where the current which flows through the armature shall enter and leave the armature, and so determines the direction of the polarity of the armature as an electro-magnet. If the brushes in Fig. 45 be moved around the commutator the point at which



Figure 52  
Armature reaction in a  
dynamo.

the current divides to pass around the two halves of the Gramme ring will move with it. It is clear that the pole of the armature will be at the point at which the current divides. The strength of the armature as an electro-magnet is directly proportional to the amount of current which is drawn from the armature. The practical effect of the armature becoming a powerful magnet is to cause more magnetic lines to pass into the armature at one side of the pole piece

than at the other, for a north pole in the armature will attract the lines from the south pole of the field and repel those from the north pole. When this action is sufficiently great, the axis along which the magnetic lines flow is rotated so as to occupy a position between the polarity caused by the fields alone and that caused by the armature alone. When the brushes are placed as in Fig. 52 midway between the north and south poles of the field, the only effect of the magnetization of the armature is to cause more lines to flow into the armature from the top of the pole piece than from the bottom. The tendency is to rotate the axis of the magnetic lines which pass through the armature. It does not directly tend to decrease the flux of the lines through the armature.



Figure 53  
Counter magnetic motive force of armature reaction.

As will be seen in the next chapter, it is necessary in order to stop sparking in a dynamo to rotate the brushes a short distance in the direction of the rotation of the armature. This produces the condition of things shown in Fig. 53, in which the armature reaction is such as to directly oppose to some extent the passage of the magnetic flux through the armature. It will be seen that if the brushes were rotated still further forward that the magnetism in the armature would still further oppose that of the fields. In arc dynamos the armature is made relatively a very powerful magnet and its magnetizing action is fully equal that of the fields. By rotating the brushes it is easy to see that the amount of magnetic flux which would pass through the armature could be very greatly altered. In the Wood arc dynamo the regu-



lation is entirely effected in this way. In the Brush arc dynamo part of the current is shunted by or around the field coils; this makes the armature relatively much stronger than the fields, and the armature reaction prevents magnetic flux from flowing through the armature, as will be more fully explained in the chapter on sparking.

When the field is relatively weak, with reference to the armature, it is necessary to rotate the brushes through a considerable arc in order to stop sparking; the rotation of brushes makes the effect of the armature reaction much greater than it otherwise would be. In fact, if the brushes of a Brush arc dynamo be always rotated to such a position that the spark is the same length, it is necessary to reduce the current in the fields only from  $9\frac{1}{2}$  to 7 amperes, to reduce the flux through the armature from a maximum to zero. The armature reaction with 10 amperes is equal in magnetizing force and opposite to that of the fields with 7 amperes.

If the brushes of a series dynamo be rocked quite well forward in the direction of rotation and current be sent through the armature alone, the magnetizing force of the armature will set up a powerful magnetizing flux through the armature and fields; and, if the machine be run as a motor, it will operate as if the field coils were in action, with the exception that it will spark furiously. In this case the armature reaction furnishes the magnetic field.

In ordinary constant potential dynamos and motors the armature reaction is a necessary evil, and the dynamo should be carefully designed so that the armature magnetizing force shall never reach more than from 1-2 to 2-3 the mag-

netizing power of the fields. That is, the ampere turns on the armature at full load should be from 1-2 to 2-3 the ampere turns on the field at full load.

As was noticed in Chapter IX, there are twice as many turns of wire required on a Gramme ring armature as on a drum armature to produce the same number of conductors, in which the E. M. F. is set up by means of the rotation of the armature; that is, the same number of amperes produce twice as many ampere turns in a Gramme ring armature as in a drum armature of the same power. This

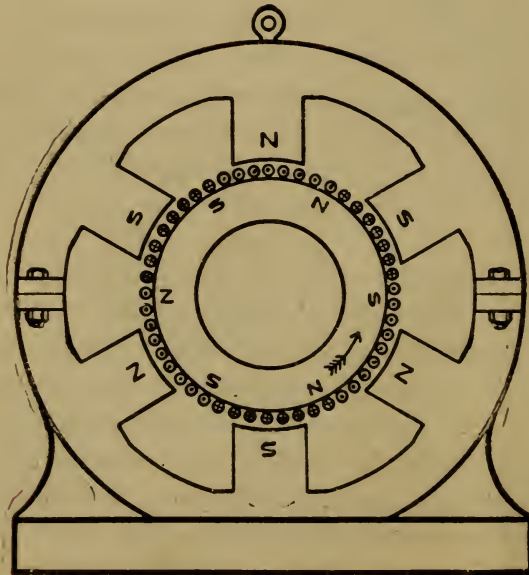

Figure 54  
Flow of current in multipolar dynamo.

- ⊙ Indicates current flowing toward the observer.
- ⊗ Indicates current flowing away from the observer.

fact make the Gramme ring a superior armature for arc dynamos where it is desired to have the armature a powerful magnet, and indicates that the drum armature is the better armature for constant potential dynamos in which the armature reaction is to be avoided as much as possible. It is to reduce the effect of armature reaction that large constant potential dynamos are made multi-polar.

Fig. 54 is the diagram of a six-pole dynamo with a drum armature, and shows the direction in which the currents in the armature flow. It will be seen that the number of turns under each pole may be made quite small, but that the number of ampere turns required on the fields will be larger on the multi-polar machine than on the bi-polar, because the area of the air gap is relatively much smaller. The small number of turns on the armature and the large number of ampere turns required on the field make it possible for the armature to carry very heavy currents, without allowing the number of ampere turns in the armature under each pole to become great enough to seriously distort the field.

## QUESTIONS ON CHAPTER XII.

1. What is armature reaction?
2. On what does the strength of the armature as a magnet depend?
3. In what way is the armature magnetized with reference to its field?
4. Why is the pole piece which the armature is leaving in a dynamo magnetized more strongly than the opposite one?
5. Why does the movement of the brushes affect the armature reaction?
6. Why does armature reaction usually reduce the amount of flux?
7. How would the brushes have to be set in a dynamo to increase the amount of flux through the armature?
8. In what kind of dynamos is it desirable to have armature reaction?
9. How is the regulation of the Wood arc dynamo effected?
10. How is the regulation of a Brush arc dynamo effected?
11. How should the brushes on a motor be set in order to dispense with the field coil?
12. In constant potential machinery, how strong is it best to make the magnetizing power of the armature at full load with reference to the fields?

13. Why is the Gramme ring an excellent form of armature for a constant current machine and a poor form for a constant potential machine as compared with a drum armature?

14. What device is used to prevent the effect of armature reaction in large machines?

15. With the same number of turns on the armature, how much will the armature reaction be reduced by changing from two to four pole?

## CHAPTER XIII.

### SPARKING.

Intimately connected with armature reaction is the sparking that occurs on the commutator of the direct current dynamo or motor. Every ordinary machine has a load at which it will spark. Consideration of Fig. 55 shows that the current is flowing through the coil in one direction just before it reaches the brush and is flowing through it in the opposite direction just after it leaves the brush. During the time that the coil is short circuited by the brush, the direction of the current is completely reversed. Fig. 55 shows

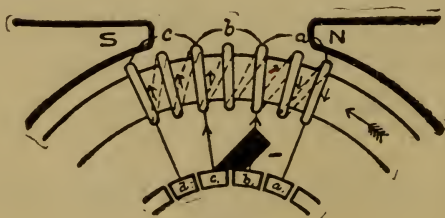

Figure 55

Commutation in Gramme ring armature.

this in detail. Three coils are shown, a, b and c. In c the current is traveling through the coil in one direction; the coil b is short circuited by the brush. In a the current is traveling through the coil in the opposite direction to that in a.

The currents in coils *c* and *a* are each equal to half the total armature current. The current in the short circuited coil will depend on the magnetic field in which it is moving while it is short circuited. If it is still under the influence of the north pole which it is leaving, the current will immediately increase as soon as it is short circuited by the brush, and may continue quite large until it is about to leave the brush. Then the resistance in its circuit, due to the small surface of the brush which rests on the commutator bar, reduces it to zero. A current must now in a very small space of time increase in the coil *b* from zero to the full value of half the armature current. The self-induction of the coil *b* prevents this from being done and the commutator bar *c*, leaves the brush before the current in coil *b* has reached its full value. A short arc is now formed between the extremity of the brush and the bar *c*, which lasts until the electromotive force has overcome the self-induction of the coil *b* and raised the current in it to half the armature current. It should be explained here that the self-induction of a coil is of the same nature as inertia in a weight. The inertia tends to prevent motion from being imparted to the weight, but when once in motion the inertia tends to prevent the weight from coming to rest.

The self-induction in a coil acts the same way with reference to the electric current. It tends to prevent the current from being established in the coil, but, when once established, tends to prevent it from changing value or from dying out.

The self-induction of a coil surrounding an iron core is very much greater than that of the same coil in the air; furthermore, the self-induction of a coil increases as the square of the number of turns in the coil.

We have traced the action in the commutation of the coil *b* where the brush is rocked so far back in the direction opposite to that of rotation that the coil *b* is still cutting the lines which flow from the pole which it is leaving. Under these circumstances it is seen that the self-induction of the coil prevents the current from being reversed until so late that a small arc forms between the point of the commutator brush and one of the commutator bars to which it is attached. This continual arcing is called sparking. When, however, the brush is rocked forward in the direction of rotation until the coil *b* is cutting the lines of force which flow from the pole which it is approaching, the action is very different. Fig. 56 shows the relative position of the poles and the coil being commutated.

When the brushes are rocked into the position shown in Fig. 56 the coil *b* is short circuited while it is cutting lines from the south pole, or the pole toward which it is approaching. The E. M. F. generated in the coil *b* will be opposite to that generated while the coil was under the influence of the north pole; therefore, as soon as the coil *b* is short circuited by the brush the E.M.F. set up therein tends to reduce the current in the coil to zero and next to generate a current in the coil to the reversed direction. If all the conditions are just right this current will be equal to half the armature current at the moment the bar *c'* leaves the brush. When these con-

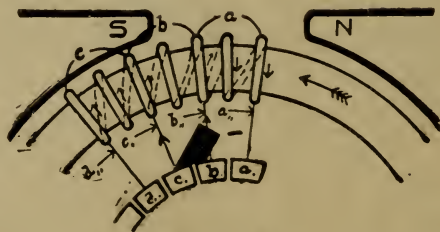

Figure 56  
Diagram of correct and sparkless  
commutation.



ditions obtain, there is no possibility of any arcing between the commutator bars and the brush, and consequently the commutation is sparkless. It is necessary that the coil b should be in a field which will not tend to increase the current that is already flowing in it at the moment that the coil is first short circuited. It is clear that the exact conditions which would make sparkless commutation possible if sparkless commutation depended only upon magnetic conditions can only exist for one particular position of the brushes and one particular load on the armature. For, suppose the coil b were short circuited in a quite powerful field of the pole toward which it is approaching, then a current flowing in it at the instant it was first short circuited would die out almost immediately and a large current would be set up in the opposite direction, and would tend to increase until broken by the bar c, leaving the brush. This would produce an arc due to over-commutation.

A factor of very great importance in commutation is the resistance between the brush and the commutator bars. It must be carefully kept in mind that while the current in the coil b is being reversed by the small E. M. F. generated in it, the main current of the dynamo is passing from the commutator bars b, and c, to the brush. There will therefore be a greater or less difference of potential between the bars b, and c, and the brush. This difference of potential or voltage will depend on the resistance between the brush and commutator bars and also upon the current. It is clear that if there should be a tendency in the coil b to over-commutate by being placed in too strong a south field, this local current must flow through the leads c,, and b,, across from the bar b, through the brush to the bar c, and to the coil. In order to do this the current which

naturally flows from the bar b' into the armature will be increased. While the current which naturally runs from the brush through the lead or connection c'' to the armature is reduced by the same quantity. This consideration will show that there is very little danger of over-commutation when the armature carries a fairly large load.

The tendency of a considerable armature current traveling from the brush into the bars and so into the armature is to immediately stop any current which might flow in the coil b, because the tendency is for the leads or connections c'' b'' to carry the same amount of current. And this tendency is increased if there is considerable resistance in the two leads c'' and b''. When these two leads are carrying the same amount of current it is manifestly impossible for any local current to circulate in the coil b. As the bar c' moves away from the brush the resistance that the current meets in flowing from the bar c' increases on account of the smaller surface of contact between the brush and the commutator bar c'. This tends to reduce the current in the lead c'', but such a reduction of the current must be accompanied by a corresponding increase of the current in the coil b.

This is because the current in the coil b plus the current in the lead c'' must always equal half the armature current, and anything that reduces the current through the lead c'' must increase the current through the coil b.

The resistance between the brush and the commutator bar c' thus powerfully tends to set up a current in the short circuited coil in the same direction that it will flow in the coil after it is completely commutated, because it tends to

produce an even distribution of current over the surface of the brush.

As the bar  $c'$  recedes from the brush the resistance to the passage of current to the left hand side of the armature by the path  $c'$  and  $c''$  increases, and this increases the tendency of the current to flow through the coil  $b$ . When the bar  $c'$  has entirely left the brush the current in the coil  $b$  will be equal to half the armature current, and in this way again sparkless commutation will have been attained.

If the brush is of carbon instead of copper, the resistance between the bar and the brush will be very much greater with brushes of the same size. But even with a carbon brush large enough to carry the current there will be from three to five times the voltage between the commutator bars and the brush that exists with a copper brush.

A still more important factor in sparkless commutation is the more even distribution of current between the brush and commutator bars that the carbon brush imposes. The resistance of the carbon is at least 100 times as great as that of a block of copper the same size, and therefore the tendency of the current to spread itself out evenly over the surface of the brush when passing from the commutator bars to the brush is very great. If this effect is great enough when the brush covers both commutator bars  $b'$  and  $c'$ , fully 25 amperes will flow from each commutator bar to the brush, provided the armature is carrying 50 amperes (see Fig. 57). When the commutator bar  $c'$  has advanced so that only half its surface is covered by the brush,  $12\frac{1}{2}$  amperes flow into the brush from the commutator bar  $c'$  25 amperes from the commutator  $b'$ , and  $12\frac{1}{2}$  amperes from the commutator bar  $a'$ , which

would by this time have half its surface covered by the brush (see Fig. 58.) At this instant the coil b would be carrying  $12\frac{1}{2}$  amperes into the left hand side of the armature and would be, so to speak, three-quarters commutated. The coil a would be carrying  $12\frac{1}{2}$  amperes into the right hand side of the armature and would be, so to speak, one-quarter commutated. As the commutator bar c' leaves the brush the current flowing from the brush into the commutator bar c' will diminish until at the instant the bar leaves the brush it will be zero, and the current in the coil b will correspondingly increase until, at the instant the commutator bar c' leaves the brush, it will be equal to full 25 amperes, or one-half the armature current. At this instant

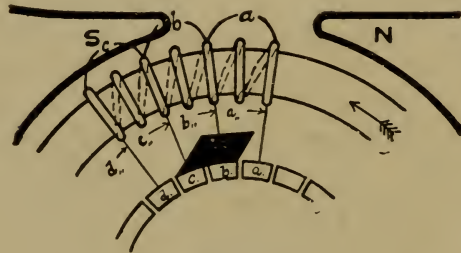

Figure 57

Current from armature 50 amperes. Current into bar c', 25 amperes and into bar b', 25 amperes. Current through both c'' and b'', 25 amperes each. Current in coil b, none. Current in coils a and c, 25 amperes each.

the brush would rest equally on the bars a' and b', 25 amperes would flow into each bar, 25 amperes would flow into each lead a'' and b'' and the current in the coil a would be reduced to zero, or it would be half commutated (see Fig. 59.)

The objection to the copper brush is that the resistance between the copper brush and the commutator is so low



copper bar to the tip of the carbon brush to fuse the copper. The action just described, viz: the distribution of the current over the surface of the brush is the most important one in the progress of commutation. The only thing which prevents this from always producing sparkless commutation is (the self-induction of the coil to be commutated. It is clear that if commutation is to take place easily this self-induction should be as low as possible. If three-tenths of a volt applied for 1-100 of a second is sufficient to overcome the self-induction of a coil of one turn on a given armature, 1.2-10 volts, or four times as much as would be required to overcome the self-induction and reverse the current in a coil of two turns on the same armature. Nine times 3-10 would be

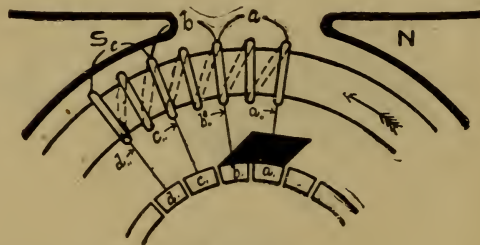

Figure 59

Current from armature 50 amperes. Brush covers all bars a' and b'. Current into bars a' and b' 25 amperes each. Current in coil a=0. Current in coil b=25 amperes. Coil b completely commutated.

required with three turns, and so on, for the self-induction of a coil on any given armature is proportional to the square of the number of turns on the armature coil.

It will be noticed that the effort to commutate the short circuited coil due to the resistance of the brush in-

creases with heavy loads; thus there is twice as much tendency for the current to flow into the brush evenly with 50 amperes as there is with 25. This gives us twice the voltage for commutating the current in a short circuited coil when 50 amperes are flowing than is available when a current of 25 amperes is being produced by the armature. On the other hand, the commutation which is produced by the short circuited coil cutting the lines of the field toward which it is approaching, grows weaker and less perfect as the load increases, because the increasing load increases the armature reaction and the increased armature reaction weakens the field which the coil is approaching, while strengthening the pole from which the coil is receding. Therefore the commutation produced by the cutting of lines of force is strongest when it should be weakest and weakest when it should be strongest. Since perfect commutation is obtained even under the most trying conditions it is clear therefore that it is produced mainly by the tendency to the even distribution of the current on the brush, and not to the character of the field in which the short circuited coil is moving. In order to obtain the best results, or even good results, it is necessary that the coil while short circuited should not be to any extent under the magnetic influence of the pole from which it is receding. We may therefore sum up the requirements to good commutation as follows: First, carbon brushes of sufficient width to give the coil time to reverse; second, low self-induction of the short circuited coil, so that only a small E. M. F. need be applied in order to reverse the current in it; third, an armature in which the reaction is sufficiently small, so that the pole toward which the short circuited coil is approaching is not very much weaker with the heaviest load than with no load.

The above description applies to the commutation in a dynamo. The same description will apply to the commutation in a motor, except that in order to obtain magnetic reversal of the coil the brushes must be rocked in a direction opposite to that of rotation so as to bring the short circuited coil under the influence of the pole which the short circuited coil is leaving instead of approaching, as in the case of the dynamo.

A little thought will show that in the case of both dynamo and motor it is necessary, in order to produce magnetic commutation, to have the short circuited coil under the influence of the pole that is weakened by the armature reaction.

Figs. No. 57, 58 and 59 show in three steps the process of commutation in coils a and b.



## QUESTIONS ON CHAPTER XIII.

1. What happens to the direction of flow of current in a coil in passing a commutator brush?

2. In a bi-polar armature how much current is passing through each coil?

3. On what does the current in the coil or coils short circuited by the brush depend?

4. What is the effect of introducing resistance in the leads between the armature winding and the commutator bar?

5. What is the condition of sparkless commutation?

6. What is the effect of self-induction in a coil?

7. How much sparking would there be if self-induction could be entirely eliminated?

8. Why is the sparking less in a dynamo and greater in a motor when the brushes are rocked forward in the direction of rotation?

9. If nothing but magnetic conditions govern sparking, would it be possible to obtain perfect commutation under all loads?

10. What is over-commutation?

11. How would you set the brushes of a dynamo so that it would spark less with a load than without a load?

12. What other important factor is to be considered in commutation?

13. What is the effect of difference of potential between the brush and commutator bars in commutation?

14. Why is over-commutation very unlikely to occur with considerable load on the armature?

15. Why do carbon brushes prevent sparking?

16. Why does the commutator run warmer with carbon than with copper brushes?

17. If means could be devised to cause the current to pass evenly from the brush into the commutator, what effect would this have on sparking?

18. Why does the carbon brush approximate this condition more closely than the copper brush?

19. Why does a brush which covers two or three commutator bars work with less sparking than one which is very narrow?

20. Describe the action of a carbon brush in producing commutation.

21. Why is sparking usually accompanied by cutting of the commutator?

22. If it is necessary to use a copper brush, what must be true of the self-induction of the coils?

23. What does the fact that motors may be run heavily loaded in both directions without sparking show as to the relative importance of the magnetic conditions and the brush design in producing sparkless commutation?

## CHAPTER XIV.

### WINDING OF DYNAMOS AND MOTORS.

The office of the wire on an electric dynamo or motor is twofold: First, wire is used on the magnetizing coils to convey the current which causes the iron or steel cores to become electro-magnets. This winding should simply be disposed and connected up so as to force the magnetic flux around the circuit. If possible, it is always better to wind the magnetizing coil in the shape of a cylinder, for a circle includes the largest possible area with the smallest possible periphery. It is, of course, the object of the magnetizing coil to drive as many lines of force as possible through its interior; at the same time it is very desirable that the length of the average turn of the field wire should be as small as possible. Therefore it is always advisable to make the cross-sections of that part of the magnetic circuit around which the magnetizing coil is placed a circle or a square with the corners cut off, or, if a laminated pole piece is used, a square. The field winding should also be placed as close as possible to the air gap. This is to prevent as far as possible magnetic leakage.

The second object of the wire on an electric dynamo or motor is to carry the current which passes through the armature. We will consider simply the case of the dynamo, for, as was pointed out in the chapter on "Electro-Motive Force," a dynamo and motor are perfectly similar machines.

and one may be converted into the other without the knowledge of an observer watching the machine in operation.

In the case of the dynamo, E. M. F. is generated in the armature wires as they pass under the pole piece. An equal amount of E. M. F. is generated in each wire, and in order to get the best result these wires must be connected up into a series, so that all the electro-motive forces generated under a field pole shall be added together.

When the winding is arranged so that this is accomplished, the current will flow in all the wires under each pole piece in the same direction. Since the E. M. F. produced under the north pole is opposite in direction to that produced under the south pole, it is further necessary to arrange the winding so that the current in all the wires under the north pole shall flow in one direction and the current in all the wires under an adjacent south pole shall flow in the opposite direction.

A study of Figs. 45, 46 and 21 will make this clearer. Any armature winding which fulfills the above conditions will operate satisfactorily. Fig. 60 is a diagram of the winding on a two-pole drum armature. Here the end of one coil and the beginning of the next coil are brought down and attached to a commutator segment. Suppose 56 coils are used on the armature and 56 bars in the commutator, and four turns on each coil, and that the armature is of such diameter as to accommodate  $56 \times 4$  equals 224 wires in a single layer. By the time 28 wires or leads are brought down to the commutator the whole surface will have been covered with a layer of wires. In order to bring down enough connections to fill up the other half of the commutator, it will be necessary to wind on a second layer

of wires over the first layer. Now between any two ordinary coils in either layer of the armature winding there will be only the difference of potential or voltage that exists between two adjacent bars in the commutator. When the last coil is wound onto the first layer it will be seen that it lies alongside of the first coil that was put on, so that between the first and last coils that are put onto the layer of the armature we have the

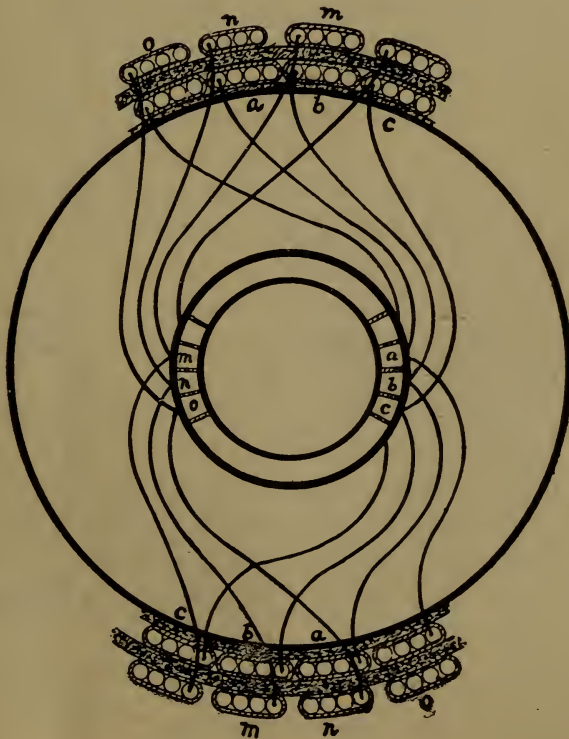

Figure 60

Diagram of connection of bipolar armature,  
horizontal winding.

full voltage which the armature is designed to carry. Therefore, while it is not necessary to insulate between adjacent coils in the same layer, it is necessary to carefully insulate between the first and last coils that go on the same layer.

A study of Fig. 60 will furthermore show that there is in every part of the armature the full difference of potential of the armature between the upper and lower layers of wires. Therefore it is necessary to insulate very carefully the upper and lower layers. A winding such as is shown in Fig. 60 is called a horizontal winding. If, instead of winding the four turns of each coil alongside each other in one layer, they should be wound with two turns in two layers a space would be left between the coils which are attached to adjacent bars on the commutator. This space may be filled by winding in a coil which is connected to a bar on the opposite side of the commutator.

Fig. 61 shows a diagram of this winding. It is to be seen that each coil must be insulated from its neighbor for the full difference of potential in the armature. This is called a vertical winding. Practically, a horizontal winding is less liable to trouble than the vertical winding, because it is easier to insulate the layers from each other than it is the vertical divisions between adjacent coils.

It is possible to carry the leads connecting the armature winding and the commutator bars a quarter revolution more or less around the armature if desired, in order to bring the position of the brushes into a more



Figure 61

Diagram of vertical winding for bipolar drum armature.



The brushes in a four-pole dynamo are placed 90 degrees apart, in a six-pole dynamo 60 degrees apart on the commutator. In a four-pole dynamo brushes opposite each other should be connected together. In a six-pole dynamo three sets of brushes 120 degrees apart should be connected together to one pole or terminal of the dynamo.

Another advantage of the wave winding as compared with the lap winding for small machines is that the number of turns of wire on the armature is half as great with the wave winding as with the lap winding.

When one is calculating the voltage which will be produced in a four-pole dynamo on which a wave winding is to be employed, it is necessary to have flux enough from each pole to produce only half the total voltage required.

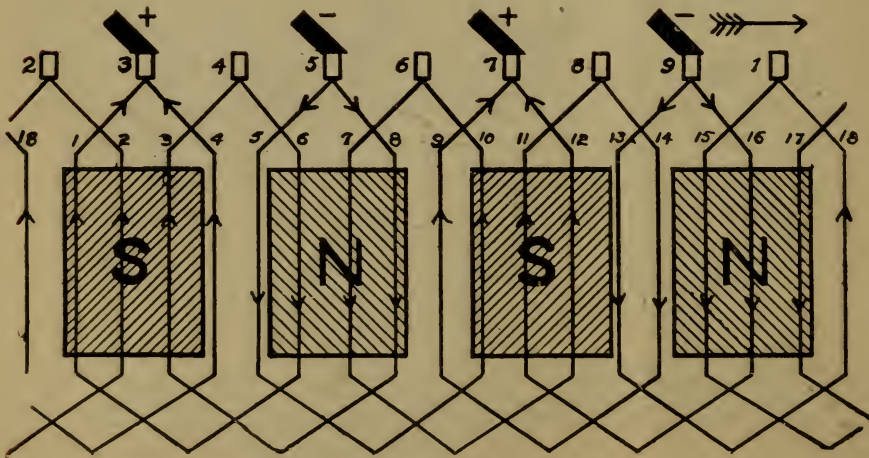

Figure 63  
Lap winding on four pole dynamo



This is on account of the fact that there are only two paths for the armature current.

The lap winding shown in Fig. 63 is perfectly analogous to the winding shown in Figs. 60 and 61. In this machine there are four paths for the current through the windings of the armature, and the connections, instead of being complicated as with the wave winding, are as simple as with the two-pole winding. By cross connecting opposite bars of the commutator it is possible to use either two or four brushes on a four-pole armature with a lap winding. In the wave winding the commutator bars are cross connected by the armature wires themselves.

In the lap winding there are four paths for the armature current through the armature. There must necessarily be four brushes on the commutator, unless the commutator is cross connected, and the voltage produced in each of the four circuits depends on the magnetic flux of its respective pair of poles.

It may happen in this way, that after the armature has worn the bearings so as to be out of center in the fields that the E. M. F. in one circuit may be considerably higher than that in the circuit on the opposite side of the armature.

In a bi-polar machine the two sides of the coil must span nearly or quite 180 degrees of the armature in order that one side of each coil may be under a north pole while the other is under a south pole. In a four-pole machine each armature coil must span nearly or quite 90 degrees for the same reason. In a six-pole machine a span in each coil of 60 degrees is required.

One peculiar thing is noticed in a wave winding on a four-pole machine, when there are about half as many slots in the armature as there are bars in the commutator. One coil cannot be connected to the commutator and must be taped up and left in the armature without any electrical connection with the rest of the armature winding. Taping up this coil makes the number of bars in the commutator one less than twice the number of slots in the armature. Table No. 10 gives the armature windings and the size of the wire required for a number of the armatures most commonly used in the United States.

TABLE No. X.

## EDISON GENERATOR WINDING.

Capacity in K. W.	Kind of Winding	Size of Wire	Wires in Parallel	Turns per Layer	Layers per Section	Number of Sections	Voltage
3	Horizontal	.072	1	3	2	44	125
6	"	.050	2	2	3	58	250
12	Vertical	.148	1	1	3	50	125
15	"	.180	1	1	2	48	125
20	"	.110	4	1	2	40	125
20	Horizontal	.083	6	1	2	66	125
25	"	.162	2	1	1	66	125
30	"	.195	2	1	1	58	125
45	"	.083	3	1	2	100	500
60	Vertical	.134	2	1	3	58	500
100	"	.120	4	1	2	80	500

TABLE No. X.—Continued.

STREET RAILWAY MOTOR ARMATURE WINDING.

Type of Motor	Kind of Core	Kind of Winding	Number of Coils or Section	Size of Wire	Diameter over Bands	Coils Span	Connections Facing Commutator
T. H. F. 20	Smooth	Hand	64	.045	8 $\frac{1}{8}$	.....	8 to right
T. H. F. 30	"	"	64	.080	10 $\frac{3}{8}$	.....	8 to right
T. H. F. 40	"	"	64	.090	10 $\frac{7}{8}$	.....	Straight
G. E. W. P. 30	Slotted	"	64	.080	.....	.....	"
G. E. W. P. 50	"	"	130	.040x.340	.....	.....	Commutator crossconnected
G. E. 800	"	"	105	.050x.186	.....	1 and 27	Wave winding
G. E. 800	"	Coil	93	.114 or .101	.....	1 and 24	"
G. E. 1000	"	"	105	.114	.....	1 and 27	"
G. E. 1200	"	"	37	.128	.....	1 and 10	"
G. E. 51	"	"	72	.101	10 $\frac{1}{2}$	.....	Straight
West D. R. No. 1	Smooth	Hand	95	.090	.....	1 and 25	Wave winding
West No. 3	Slotted	Coil	93	.101	.....	1 and 13	"
West No. 12	"	"	93	.101	.....	1 and 11	"
West No. 12 A	"	"	95	.101	.....	1 and 25	"
Walker No. 4	"	"	51	.144	.....	1 and 14	"
Walker No. 10	"	"	99	.109	.....	1 and 26	"
Steel Motor Type C	"	"	33	.144	.....	1 and 9	"
Steel Motor 50 H. P.	"	"	56	.083	.....	.....	Straight
Edison No. 6	Smooth	Hand	120	.050	9 $\frac{3}{4}$	.....	Commutator cross connected
Edison No. 14	Slotted	"	.....	.....	.....	.....	.....

The windings given above cover the types and H. P. of the armatures most generally used.

TABLE No. X.—Continued.

## WINDINGS OF ARC-ARMATURES.

Type of Armature	Capacity in Lights	Size of Wire	Number of Sections	Number Layers per Section	Number Turns per Layer	Candle Power
Brush No. 7	30	.083	8	17	36	2000
Brush No. 8	65	.083	12	21	30	2000
Brush No. 9	85	.083	24	23	19	2000
Brush No. 10	100	.083	24	23	21	2000
Brush No. 11	125	.083	24	22	24	2000
T. H. Ring M. D.	50	.072	30	15	11	2000
Schuyler	50	.057	8	8	37	1200
Wood No. 8	60	.064	120	11	6	1200
Wood No. 9	80	.072	120	13	6	1200

## COMPOUNDING OF DYNAMOS.

We have considered heretofore two general methods of field winding, viz: shunt and series. A combination of these two methods is called compound winding. In a shunt wound dynamo the excitation is almost constant, but the voltage produced by the dynamo decreases as the load increases, due to four causes: First, in order to obtain sparkless commutation the brushes are rocked forward into such a position that the coil, while short circuited by the brush, is under the influence of the pole toward which it is approaching. The armature reaction with the brushes in this position decreases the magnetic flux. This lowers the voltage. Second, the armature reaction tends to bunch the lines very greatly under one side of the pole and to thin them out under the other side of the pole. In a surface wound armature this action does not greatly alter the total magnetic flux, but when an ironclad armature is employed the armature teeth are saturated by the action of the normal field, and the effect of the armature reaction cannot greatly increase the flux of the lines under the dense end of the pole piece. Consequently all the lines which are prevented from passing into the armature at the other end of the pole piece practically diminish the total magnetic flux by just this amount. Third, the current flowing through the shunt fields is decreased, owing to the loss of voltage produced in the armature by the effect of the armature reaction. Fourth, a reason which in large armatures is of practically little importance is the loss of voltage due to the resistance of the armature. The combined effect of these actions is to reduce the voltage from 5 to 25 per cent. between no load and full load.

It is desirable, of course, that the dynamo produce at the lamps a perfectly constant voltage. To satisfy this condition the voltage at the dynamo at full load must be greater than the voltage at no load by the amount of the loss of voltage in the line. In order to accomplish this result and counteract the effect of armature reaction, a series winding is put on to the fields of the dynamo. The effect of this series winding is to increase the ampere turns on the field coils in proportion to the load. Therefore, when the armature reaction tends to reduce the voltage by the greatest amount the series coils tend to increase the voltage to the greatest extent. By using the proper number of series turns the effect of armature reaction can be overcome and the voltage increased as the load increases, thus making up

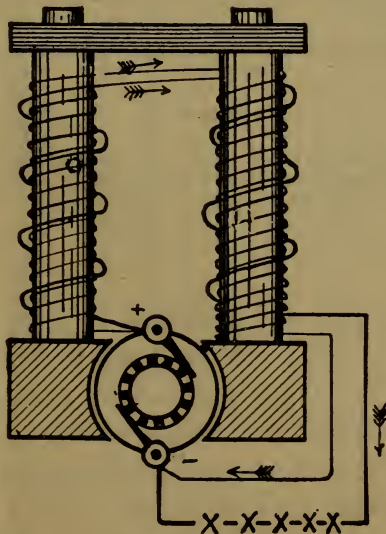

Figure 64

Diagram of compound winding in a dynamo.

for line loss. Fig. 64 is the diagram of compound winding on a dynamo. Fig. 65 shows the effect of the series coil.

Compound winding can be used on motors as well as dynamos. The effect here is to increase the torque and decrease the speed of the motor as the load increases. A little thought and a consideration of Fig. 20 will show that the torque or twisting effort is proportional to the current

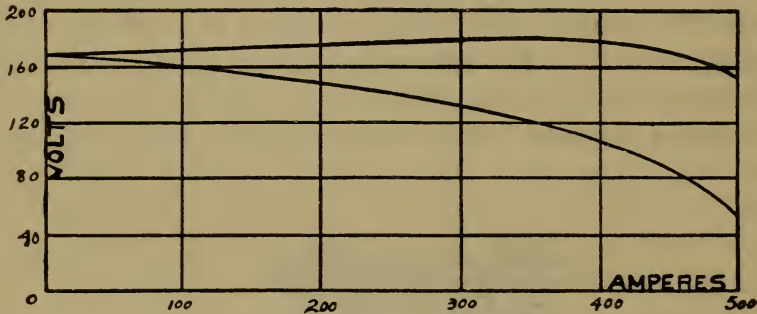

Figure 65

Upper line shows the current and voltage when series coil is used.  
Lower line shows current and voltage when plain shunt winding is employed.

which flows through an armature as long as the field is constant, and is always proportional to the product of the current through the armature and the strength of the field. An advantage of compound wound motors is that the speed variations which will occur when a plain series wound motor is used are confined within definite limits. At the same time the advantages of the series motor are obtained, viz: First, powerful starting torque; second, the decreased effect



of armature reaction, which shows itself in freedom from sparking at heavy loads. In calculating the number of ampere turns required on a compound wound dynamo, it is necessary to calculate the number of ampere turns that would be required to force five or ten per cent. additional flux through the circuit.

The effect of the shunt coils is usually sufficient in an ironclad armature to saturate to a considerable extent parts of the magnetic circuit. This makes it necessary that the ampere turns of the series coil should be much greater than would otherwise be necessary.

In practice the ampere turns of a series coil at full load vary from one-third to one-half the ampere turns of the shunt coil.

## QUESTIONS ON CHAPTER XIV.

1. For what two purposes is wire used on a dynamo or motor?
2. Why is it desirable to make the section of the field coil circular?
3. What advantage is gained by placing the field coil near the air gap?
4. In order to have a motor winding properly arranged, what must be the direction of the current in all the wires under each pole piece?
5. Why does the coil winding on a four-pole dynamo span one-quarter of the circumference of the armature?
6. How many degrees will a coil span in an armature intended for a ten-pole machine? Why?
7. Why is it necessary for the current in all the wires under the north pole of a motor to flow in one direction and in the opposite direction under the adjacent pole?
8. What is the difference of potential between the first and last coils in the same layer of a two-pole, two-layer horizontally wound armature intended for 500 volts?
9. If the armature has 64 sections, what would be the difference of potential between the third and fourth coils? Eleventh and twelfth?

10. In the same armature, what would be the difference of potential between the upper and lower layers of wire?

11. What is a horizontally wound armature?

12. What is a vertically wound armature?

13. How is it possible to connect the armature to the commutator so as to have the brushes set in any desired position?

14. What is a wave winding? What is a lap winding?

15. What are the advantages of wave winding for machines up to 100 horse power?

16. Why are the brushes in a six-pole dynamo placed 60 degrees apart?

17. Explain why a six-pole armature with a wave winding may have its brushes placed in the same position as a bi-polar machine?

18. A four-pole wave wound armature has a flux of one and a half millions of lines; the speed is 1,200 revolutions per minute; there are 45 slots in the armature and each coil has four turns in it. What will be the voltage produced?

19. What will be the voltage produced by the same armature if lap winding is used?

20. What will be the relative resistance of the armatures with wave and lap winding?

21. How may a lap wound armature for a four-pole machine be connected so as to operate with two brushes?

22. What will be the difference in operation of a wave and a lap wound armature when the armature is not central in the pole pieces?

23. Why is it impossible to use an armature in a four-pole wave wound machine with an even number of slots if there are the same number of commutator bars as armature slots?

24. Make a diagram for a wave winding for a four-pole armature having 12 slots in the armature and 23 bars in the commutator?

25. What is a compound wound dynamo?

26. What is the object of putting a series coil on a dynamo?

27. Why does the voltage of a plain shunt wound dynamo decrease with the load?

28. If a bi-polar dynamo produces 200 amperes and the shunt ampere turns are 2,600 on each coil and there are eight turns in the series coil, what will be the total ampere turns on each field coil at full load?

29. What is the effect of compound winding on motors?

30. What are the advantages of compound wound motors over plain shunt wound motors?

31. Why will a 500-volt compound wound dynamo that operates very well on 500 volts greatly over-compound when operated at 250 volts?

## CHAPTER XV.

### PROPER METHODS OF CONNECTING UP DYNAMOS AND MOTORS.

It is a fact, and one which for a long time remained undiscovered, that a dynamo will excite itself when run at the proper speed and with proper connections between armature and fields. It is also true that in order that a machine may excite itself or excite its own field magnets, it is first necessary to send a current from an external source around the field magnets. This current drives a certain amount of flux through the magnetic circuit, and since most of the magnetic circuit is composed of iron, a part of this flux does not disappear when the current is cut off. This permanent magnetism is called residual magnetism. The residual magnetism will be greater in a dynamo with an ironclad armature than in one with a smooth core, because the magnetic circuit is so much more perfect. The residual magnetism in most cases will be greater with cast iron field cores than with wrought iron or soft steel. The amount of this residual magnetism with an ironclad armature varies from one to five per cent. of the total flux with fully excited fields. The writer has seen a 500-volt street railway generator which had a residual magnetism such that it produced 25 volts when the armature was run at full speed. This residual magnetism produces a voltage in a certain direction depending upon the way in which the current has

been flowing through the field coils and upon the way in which the armature is connected up to the commutator. In order that a dynamo may excite itself, it is necessary that the current produced by the residual magnetism shall flow in such a direction as to strengthen this residual magnetism. If the current produced by the residual magnetism flows through the field coils in the opposite direction this will tend to weaken the residual magnetism and consequently to reduce the current which flows. If, on the other hand, the current produced by the residual magnetism flows through the field coils in such a direction as to strengthen it, the greater magnetism which results will strengthen the current, and this in turn strengthens the field, and this process goes on until further increase in the magnetism is prevented by the saturation of some part of the magnetic circuit. It often happens that when an armature is re-wound the connections between the winding and the commutator are made in such a way as to reverse the direction in which current flows from the armature; that is, the brush which before the armature was re-wound was a positive brush may become a negative brush. This reversal of the direction in which current flows in connecting up an armature is easily made and very frequently occurs. The re-wound armature when put into the old field produces a current which tends to flow in the opposite direction from that of the old armature.

This current tends to reduce instead of strengthen the residual magnetism, and the result is that the machine will not excite itself or refuses to build up. In order to correct this difficulty, it is only necessary to reverse the connections between the armature and the field coil, so that the current produced by the residual magnetism may flow in such a

direction as to strengthen this residual magnetism. To do this either the leads from the armature may be crossed or the leads from the field may be reversed. When the fields have both series and shunt coils it is usually more convenient to reverse the armature leads than it is to reverse the leads from both series and shunt coils. When, however, the field has only a single winding it will usually be found to be more convenient to reverse the field leads. An excellent method of determining whether the armature and fields are connected in such a way that the machine will not build up is to measure the residual magnetism with a volt meter with the field circuit open, then close the field circuit, and if the voltage drops it is almost a certain indication that the armature and field connections are reversed. In connecting up a compound wound dynamo to its circuit it is necessary to be sure that the shunt coils and series coils tend to drive the lines around the magnetic circuit in the same direction. If the series coil is connected up in the opposite direction to the shunt coil the dynamo will build up all right and will work satisfactorily on very light loads. When, however, the load becomes even, five or ten per cent. of full load, the voltage drops off very rapidly and it is impossible to get full voltage with even half the load on. This is because the ampere turns due to the series coil decrease the total ampere turns acting on the magnetic circuit instead of increasing them as the load comes on. This lowers the magnetic flux and of course lowers the resulting voltage.

All shunt and compound wound dynamos are provided with a rheostat, which is placed in series with the shunt field magnetizing circuit. This rheostat is a resistance capable of adjustment by hand by means of which the current flow-

ing through the shunt first coils may be regulated. When this resistance is all cut out the maximum current flows through the shunt fields and they consequently have a maximum magnetizing power and the maximum voltage is produced. If this voltage is too high, it is necessary only to insert more resistance in the shunt fields by a movement of the rheostat and thus cut down the magnetizing power of the fields and therefore the voltage produced by the dynamo.

It sometimes happens that a dynamo refuses to build up because there is so much resistance in the rheostat that the current produced by the residual magnetism is not powerful enough to sufficiently increase the magnetism of the fields to begin the building up process. Therefore if a machine refuses persistently to build up it is a good plan to short circuit the rheostat. This cuts out the resistance and at the same time bridges any possible open circuit that there may be in the rheostat. The rheostat should be arranged so that the field circuit can never be suddenly broken. This is to avoid the possibility of breaking down the insulation of the field coils by the so-called field discharge. A field discharge is said to occur when the shunt circuit of a dynamo in operation is suddenly opened. Anyone who has done this knows that a very long thin arc is produced; the length of the arc indicates the high voltage produced by the discharge and the small size of the arc shows that the current is comparatively weak. A calculation will show what the voltage produced by such a field discharge may be. Suppose a shunt field of a 110-volt dynamo is composed of two coils each of 1,500 turns, also that the magnetic flux passing through these coils amounts to 4,500,000 lines. If this circuit is opened in one second, the voltage which would be produced will be  $2 \times 1,500 \times 4,500,000$  divided by 100,000,000



or 135 volts. When the field circuit is opened in 1-100 of a second, the voltage will be

$$\frac{1,500 \times 2 \times 4,500,000}{100,000,000} \quad \text{equals} \quad \frac{1,500 \times 2 \times 4,500,000 \times 100}{100,000,000}$$

$$\frac{1}{100}$$

or 13,500 volts. Such a voltage as this is very apt to puncture the insulation of a field coil and care should be taken that the circuit is never opened in such a way as to expose the insulation to such a strain. The production of an extremely high voltage in this manner is simply a reproduction on a larger scale of the ordinary battery and spark coil used for igniting gas engines. In the ordinary spark coil the current from a battery of two or three volts is passed around a magnet and then suddenly opened with the production of a spark from one-fourth to one inch in length. Here we have the production of many hundreds of volts from two or three. The same multiplication takes place when a shunt field is opened suddenly.

Rheostats for the shunt circuit of a dynamo should have sufficient resistance, so that when it is all inserted the voltage in the dynamo will slowly sink to zero. This method of stopping the action of a dynamo is perfectly safe and should be followed wherever possible. Fig. 66 shows another diagram of the connections of a compound wound dynamo.

Almost all stationary motors are plain shunt wound machines. Fig. 67 is a diagram of the way in which these

motors should be connected up. The essential point in this scheme is that the shunt field circuit be always closed through the rheostat and armature so that a field discharge is impossible. The rheostat is inserted for the purpose of not permitting too great a rush of current through the armature before it has attained its speed and consequently its counter E. M. F.

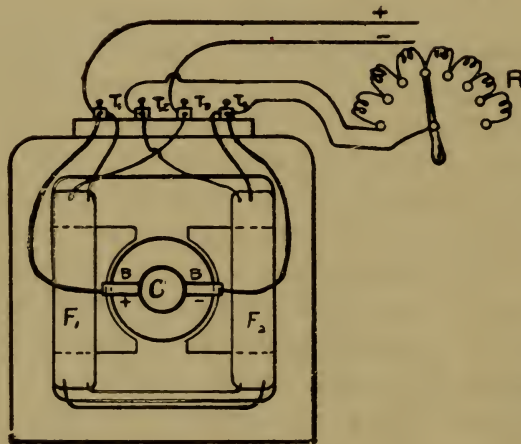

Figure 66

Diagram of connections of compound wound dynamo.

If this rheostat were arranged so that when it was thrown off, the armature circuit should be opened, the opening of the main switch would break the current through the shunt fields and produce a field discharge. An arrangement of a starting rheostat like this has been the cause of numberless burn-outs in field coils. If, however, the resistance of the starting rheostat is simply sufficient to choke the current

back to the desired amount and does never open the armature circuit, the opening of the main switch simply cuts the current off the motor. The instant after the main switch is opened the motor armature becomes a dynamo armature at practically the same voltage and supplies the field coils with current almost as long as the armature continues to revolve. In this way there is absolutely no possibility of such a disturbance of the shunt circuit such as will produce any abnormal strain on the insulation.

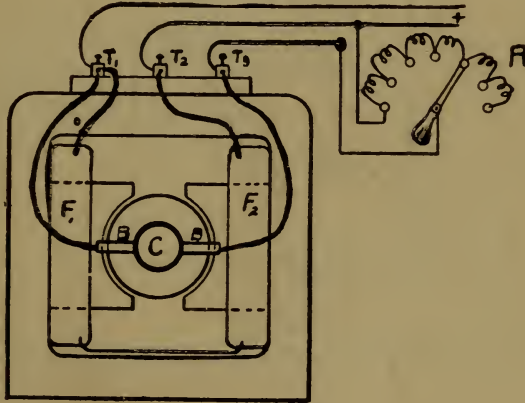

Figure 67

Diagram of connections of plain shunt wound motor.

An automatic rheostat or starting box is one which is provided with a spring, which tends to throw the handle back to the position of greatest resistance. (See Fig. 68.) A magnet holds the handle in opposition to the spring in that position in which all the resistance is cut out. The

magnet is usually energized by the current which passes through the shunt coils on the motor. If, for any reason, the power which operates the motor should fail, the magnet will weaken and release its hold. The spring will force the handle back to the position of greatest resistance, and when the power is again thrown on the line the motor will start up in the ordinary way.

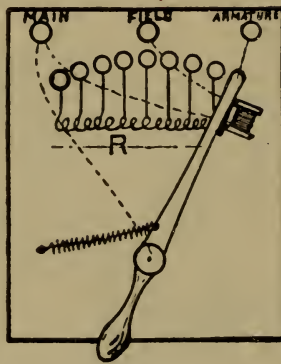

Figure 68

Diagram of automatic starting box showing connections.

If the resistance in the starting rheostat were entirely cut out and the power was thrown onto the motor from ten to a hundred times full load current would flow through the armature, causing very bad sparking and almost certainly blowing the fuses which protect the motor.

Overload rheostats are those in which the resistance is cut in where the current exceeds a certain amount.

In one design of overload rheostat the magnet spoken of above has two windings, a shunt winding which is the more powerful and a series winding in oppositon to it. With normal load the series winding does not diminish the strength of the magnet sufficiently to release the rheostat handle, but with an overload the magnet is weakened sufficiently so as to release the rheostat handle and insert the resistance of the starting rheostat in the armature circuit.

## QUESTIONS ON CHAPTER XV.

1. What is the effect of residual magnetism in the self-excitation of dynamos?
2. Would a dynamo in which there was no residual magnetism excite itself?
3. Why will reversing the connections of the shunt coil prevent a dynamo from generating?
4. What is the amount of residual magnetism in ordinary iron-clad dynamos?
5. When a machine begins to build up, what causes the voltage to stop rising?
6. If a dynamo could be made without iron that would build up if supplied with a residual field from an external source, what would be true of the voltage generated by such a dynamo?
7. If an armature fails to build up, what course should be pursued?
8. How is it possible to be certain that the armature and field magnet connections are properly made with reference to the residual magnetism?
9. How will a compound wound dynamo act when the series and shunt coils are reversed?
10. Why does moving the arm of a rheostat raise or lower the voltage of a shunt or compound wound dynamo?
11. What is a field discharge?

12. What will be the voltage from a field discharge from the Edison dynamo on Fig. 26, if there are 1,500 turns on each coil and the circuit is broken in 1-50 of a second?

13. What will be the voltage produced if there are 5,000 turns on each coil and the circuit is broken in 1-80 of a second?

14. How should the rheostat in series with the shunt coils of a dynamo be arranged?

15. Why is it desirable to have a starting box for a shunt wound motor that will never break the circuit?

16. Explain why a field discharge is impossible with a starting box arranged in this way.

17. What is the object of the automatic starting box?

18. How are overload automatic rheostats arranged?

## CHAPTER XVI.

### DISEASES OF DYNAMOS AND MOTORS: THEIR SYMPTOMS AND HOW TO CURE THEM.

#### A.—Open Circuits.

The current in an armature flows from section to section of the armature winding and usually has to pass to the commutator to pass from one section to the next. Occasionally one of the lead wires from the armature winding to the commutator becomes broken; this prevents the armature current from flowing through this path in the armature. But it will be noticed that when the coil containing the broken wire is short circuited by the brush, current will flow through the whole armature in a normal manner. As soon, however, as this coil leaves the brush the armature current in attempting to complete its circuit through this half of the armature winding will arc from one commutator bar to the next one in its attempt to flow through the circuit in spite of the broken wire. This arc will show itself as a very bad spark at light loads or as a ring of fire traveling around the commutator if the voltage is high enough to keep up the arc. With heavy loads the sparking becomes very furious and the insulation which separates the two commutator bars between which the arc occurs will be melted out. Any one who has once seen the effect of an open circuit on a commutator cannot fail to recognize it if seen a second time. It may be that the open circuit is caused by the melting of the solder, which



attaches the armature wire to the commutator bar. If the armature winding is completed by having the outside of one coil and the inside of the next coil soldered into the commutator bar the melting of the solder will make a true open circuit. If, however, the connection between the armature winding and the commutator bar is such as is shown in Figs. 57, 58 and 59, the open circuit will be only partial and will show itself only in increased sparking.

The cure for an open circuit is obviously to find the broken wire and repair it. If the trouble has been due to the melting of the solder in the commutator bars these wires should be thoroughly re-soldered at once. If, however, the wire is broken in the armature somewhere and it is desired to operate the machine temporarily, the two bars across which the arc occurs may be soldered together or connected together in some other way, so that the armature current may be able to complete its circuit through this temporary bridge. It is possible to run an armature temporarily repaired in this way for several weeks without serious trouble.

#### B.—Short Circuits.

If, in a properly wound and connected armature, two of the commutator bars be connected together, the voltage which is produced in the coil connecting these bars will produce a very great local current, which will flow through the coil and complete its circuit across the two commutator bars. Such a connection would be a short circuit, and any connection that allows a local current to flow through a part of the armature winding is called a short circuit.

Suppose an armature with a resistance of 1-10 of an ohm has fifty coils; the resistance of each path in the ar-

mature will be 1-5 of an ohm and the resistance of each coil will be 1-25 of 1-5, or 1-125 of an ohm. If, now, this armature is capable of producing 250 volts each coil in it generates 10 volts on the average. When the armature is working properly this 10 volts simply adds itself to the voltage produced by the other coils and is expended in forcing the armature current through the external resistance. If, however, the two bars to which this coil is connected be short circuited, this 10 volts will expend itself in producing a very great local current through this short circuited coil. The coil generates 10 volts and its resistance is 1-125 of an ohm. The current which will flow then will be 1,250 amperes; this is enough to heat the coil red hot and entirely destroy the insulation in its neighborhood. Trouble of this sort is the most destructive that can occur in an armature, for it usually compels the re-winding of the whole armature. If the short circuit is discovered before the coil has been sufficiently heated to destroy the insulation, and it is absolutely necessary to use the armature temporarily and the point at which the coil is short circuited cannot be discovered, each turn of the short circuited coil may be cut in two and then the two commutator bars between which this coil is connected may be soldered together. It often happens that one wire in a coil touches its neighbor at some point, and when this occurs only one turn of the coil will be short circuited and only one turn will get hot.

A short circuited coil always shows itself by getting warmer than its neighbors at first, and if not soon discovered will smoke and finally set fire to the insulation.

If an armature is completely short circuited, as, for instance, from top to bottom layers in a horizontally wound armature or from coil to coil in a vertically wound arma-

ture, it will refuse to build up if it is a generator and will turn a half revolution at a time if it is a two-pole motor, or a quarter revolution if it is a four-pole motor. In a bipolar machine the short circuit of the armature will not affect the distribution of the current when the short circuit is 90 degrees from the brushes, for then the two opposite sides of the commutator are at no difference of potential and no current will flow in the short circuit.

### C.—Sparking.

The principles which govern perfect commutation were explained in the chapter on "Sparking," but many other causes beside improper design of the dynamo may cause a machine to spark. When the commutator is in good condition, true and smooth, and the brushes have a firm contact against it and the machine invariably sparks at a heavy load, the trouble may be attributed to a poor design. In a well designed machine the causes for sparking will be a rough commutator, a commutator out of round, or brushes not having sufficient contact against the commutator.

In fact, the causes of sparking may be divided into two classes—sparking from electrical causes and sparking from mechanical causes. The cause of the electrical sparking was explained in Chapter XV.

In most machines built at the present time any sparking that there may be is principally due to mechanical causes. It is clear that in order to have sparkless running the brushes must at all times touch the commutator. The fact that from some cause or other the brushes do not touch the commutator all the time is the cause of most cases of sparking. If the brush is not free to move, sparking will

result, for even in the best machines there will be some movement of the commutator with reference to the brush, and if the brush cannot follow it there will be a very short arc that maybe will not be seen until the commutator is blackened and burned at one spot.

When an armature is slightly out of balance and is running at a very high speed, there will be a vibration of the commutator, and if the machine is to run sparkless the brushes will have to follow this vibration of the commutator. In order that the brushes may follow the movements of a commutator that is not running perfectly true, the moving part of the brushholder should be as light as possible and the spring tension that holds the brush against the commutator should be as heavy as possible. This condition is best fulfilled in a brushholder in which the brush alone moves, for in such a brushholder the inertia of the moving part is as small as it is possible to obtain, and consequently a comparatively small pressure will enable such a brush to follow the uneven motions of the surface of the commutator.

The writer once saw a motor which ran at 3,700 revolutions per minute, which could not be prevented from sparking when solid brushes were used, owing to the fact that the commutator did not run perfectly true. When leaf copper brushes were employed on this same commutator the motor ran almost sparkless, due to the fact that the copper, with its large number of separate leaves, always made contact with the commutator. Another cause which prevents the brush from touching the metallic part of the commutator is the use of insulation between the commutator bars that does not wear down as fast as the commutator bars themselves. After the machine has run for a time these

insulations project above the copper bars and produce both heating and sparking. Poor construction of the commutator is another prolific cause of sparking. If the commutator is not perfectly tight the centrifugal force will throw out one bar more than its neighbor, and consequently there will be spots on the commutator that the brush cannot make contact with. A commutator must be mechanically clean in order to run sparklessly. Spots of paint or dirt may be on a commutator and get between the brush and the copper bar, and so prevent perfect contact at one point in the commutator and produce sparking.

A cause which produces as much sparking as improper mechanical arrangement of the brushholder is improper setting of the brushes. As explained in the chapter on sparking, there is a proper place for the brushes, and if they are not placed in this position there will be a tendency to spark. The brushes being in a wrong position will first heat the commutator and roughen it, and when the surface of the commutator is impaired, sparking will result. In a dynamo the brushes should be rocked forward in the direction of rotation into such a position at no load that the voltage is two or three per cent. lower than the maximum voltage. In a motor the brushes should be rocked backward into such a position that at no load the speed is increased about two per cent. above the lowest speed.

#### D.—Heating the Commutator.

Abnormal heating of the commutator is due to one of four causes: First, friction of the brush against the commutator; second, improper position of the brushes so that there is forced commutation; third, abnormally heavy currents being taken from the armature; fourth, poor contact

between brushes and commutator. As soon as it is determined to which of these four causes the heating is due, the remedy in each case is obvious. The heating of the commutator in many instances may be remedied by the substitution of copper brushes for carbon brushes. First, because the friction between the commutator and the copper brush need not be so great as between the commutator and the carbon brush, and still more important because the electrical resistance between the commutator and the brush is very much less with the copper than with the carbon. The objection to the use of the copper brush on any commutator is that unless it is given very careful attention it will cut the commutator in the same way and for the same reason that a bearing without oil will cut.

E.—Grounds.

When a machine is out of order the first thing to do in testing it is to find whether or no there is a connection between the winding and the frame of the dynamo or motor. Such a connection is called a ground. A single ground on a machine does not of itself impair its action; it only renders the insulation in some other part of the machine very liable to break down. When there are two grounds on a machine there will be a short circuit of more or less of the winding, for the current will run from one part of the winding through one ground through the frame of the machine through the second ground to the other part of the winding. Such a short circuit usually shows itself very plainly by burning the insulation and usually stopping the operation of the machine.

Some motors, as, for instance, street car motors, are built with one end of the winding grounded to the frame. The object of this is to allow the current after it has pass-

ed through the motor and done its work to escape through the motor frame, axles and wheels of the car to the rails. When such a motor as this is to be tested for a ground it is necessary to open the connection between the winding and field frame before the test is made. Testing for ground is usually done with a small dynamo provided with a field made of permanent magnets and operated by hand. When current passes through the circuit its presence is made known by the ringing of a pair of small bells.

Partial grounds, as, for instance, in the mica insulation of a commutator, may cause severe heating of a part of the commutator, due to the arc that is formed between the commutator bars and the commutator core. It is possible by the use of a Weston volt meter to determine just where the ground is in an armature, provided the ground is perfect or nearly so. Pass current from an external source between the armature core and the winding, and test the voltage when the wire carrying the current rests upon a certain commutator bar. Next, move the wire carrying the current four or five bars in one direction, and measure the voltage again. If the voltage is higher in the second case than in the first, it is clear that the current passes through more of the armature winding in the second case than in the first. It will be necessary then to move the other way. Keep on testing in this manner until a bar is found that gives the lowest voltage. Either the ground is in this commutator bar or it is in the armature winding in the coil that is connected to this bar. To determine this point, unsolder the armature wire from the commutator bar and test each separately. Even when the ground is imperfect it is possible to locate it within one or two bars of its exact position. The armature wires may be unsold-

ered from several commutator bars and each coil tested separately with a magneto bell.

A single ground between a series and a shunt coil may practically short circuit a dynamo, for the series and shunt coils are connected together on one side of the machine, and if a ground should occur between the other extremity of the shunt coil and a series coil, a complete short circuit would result.

#### F.—Open Circuit in Field Coil.

If for some reason one of the wires in the shunt field coil of a motor or dynamo should become broken, the machine would not operate, because it would be impossible to produce any magnetic flux. This would show itself in a dynamo by the refusal of the machine to build up. In a motor it would show itself by the refusal of the motor to pull any load and by blowing the fuses when the starting rheostat is nearly cut out. In a motor a very easy way to test this is to see whether the fields are excited as soon as the switch is closed by presenting a knife or any magnetic object to the magnet pole. Another way of making the test is to open the armature circuit and close the main switch, and then open it slowly. If the field wire is broken there will be no current; if the field is in perfect condition there will be an arc upon the opening of the switch. If there are two or more field coils on the motor it is easy to determine the one in which the broken wire is situated by turning on the current and then short circuiting one after the other until one is found which, when short circuited, allows the current to flow through the other coils. This coil will have to be removed and rewound.

#### G.—Short Circuit in Field Coils.

If, for any reason, the beginning and end of a coil come in contact, the resistance of the coil between these two



points is cut out, and the current will flow only through a part of the coil. In practice this coil will show itself by running cooler than the others, because the same current runs through a greater resistance through the other coils than in the short circuited coil. By measuring the voltage across the damaged coil and across a good coil the amount of the damaged coil which is short circuited may be determined. This coil will have to be removed and rewound. If, from any cause, such as long use or improper ventilation, the insulation on the wire in a coil becomes charred, so that it is no longer a good insulator, the current, instead of flowing through all the turns of a coil, will leak from layer to layer. Such a coil is said to be "burned out," and may be detected by running cooler than a coil in good condition and by having very much less magnetizing power. It is to be observed that when a shunt field coil becomes short circuited or "burned out," it throws a great deal more load on the other field coils; for instance, if there are two field coils on a motor which normally take one ampere at 220 volts, the watts wasted in each coil will be 110. If, now, one of these coils be short circuited, the only resistance in the circuit will be that of the other coil, and the current through this coil will be two amperes, because one coil has only half the resistance of two. The voltage on this coil will be 220 volts; therefore 440 watts will be wasted in it, or four times the normal heat loss. It is easy to see that if one coil should become short circuited this would be almost certain to burn out the other coil.

#### H.—Improper Connection of Field Coils.

It is easy to see that in order to be effective the field coil must be connected up in such a way that it forces the flux around the circuit in the same direction

that its mates do. Thus in the Edison dynamo shown in Fig. 23, if the field coil should be connected up in such a direction as to make both pole pieces north poles, it is obvious that there would be no magnetic flux through the armature. If this machine were used as a motor the armature would not run with even a small load. In order to detect this trouble it is necessary to test the polarity of the field coils with a compass. If it is found that both poles are the same it will be necessary to reverse the connections of one of the field coils. If the field coils should be connected up in this way on a dynamo it would refuse to build up, and the only way to detect the trouble would be to send current through the field coils from an external source and test the polarity of the pole pieces with a compass. Great care should be taken when putting on a repaired field coil to see that it is connected up correctly.

#### I.—Heating of Field Coils.

When all the field coils on a new machine rise to a temperature of over 70 degrees Fahrenheit above the surrounding air they are too warm to be durable, and it is an indication that not enough wire has been used in the field coil by the manufacturer.

When on an old machine a coil gets warm while another is much cooler, it is, as explained above, usually due to a short circuit or a partial burn out in the cool coil. The coil that is hot is the one that is still in good condition. The only way to prevent the heating in all the shunt field coils is to increase the amount of wire on the coils.

#### J.—Noise When a Machine is in Operation.

In machines having ironclad armature a humming or singing noise is occasionally heard when the armatures run

with fully excited fields. This occurs in machines which have short air gaps usually, and is due to the magnetic pull exerted on the tooth of the armature as it suddenly comes under the influence of the field magnet. The mechanical force due to the magnetic attraction between the armature and field magnet is sufficient to mechanically stretch out the tooth a fraction of a thousandth part of an inch. This produces a small air wave and a rapid succession of these as the armature passes under the field magnet produces the noise.

In itself the noise is not harmful but is occasionally an indication of tufting of the magnetic lines as they pass from the pole piece into the armature teeth. As was learned in a former chapter, this tufting of the magnetic lines produces eddy currents in a solid pole piece which wastefully heats it.

## QUESTIONS ON CHAPTER XVI.

1. What is an open circuit?
2. How does an open circuit show itself?
3. How may an open circuit be temporarily repaired?
4. What is a short circuit?
5. How much current will flow in a short circuited coil in a 110-volt armature, if there are 40 sections in the commutator and the resistance of the armature is 2-100 of an ohm?
6. How will a short circuit show itself?
7. What will be the effect of a short circuit between the upper and lower halves of a horizontally wound armature?
8. How will a short circuited armature operate in a motor?
9. What is the most ordinary cause of sparking?
10. What is the principal mechanical necessity in order to prevent sparking?
11. Name some of the causes which prevent the brushes from touching the commutator continually?
12. What is the objection to a heavy brush holder with a carbon brush rigidly clamped into it?
13. What is the effect of improper setting of the brushes?

14. In what direction should dynamo brushes be rocked as the load increases to prevent sparking?

15. In what direction should motor brushes be rocked?

16. What are four causes of heating the commutator of a machine?

17. What is a ground?

18. What is the effect of two grounds on the same machine?

19. Is it possible to successfully operate a grounded machine?

20. What is necessary to do before a street car motor can be tested for a ground?

21. How is it possible with a Weston volt meter to locate the position of a ground on an armature?

22. How may a ground between a series and a shunt coil short circuit a machine?

23. How will an open circuited field coil show itself?

24. How is it possible to locate an open circuited field in a motor?

25. What is the effect of a short circuit in a field coil?

26. Why will a short circuited field coil run cool while a short circuited armature coil becomes very warm?

27. Why will one short circuited field coil almost certainly burn out its mate if there are only two on the machine?

28. What is the effect of improper connection of the field coils?

29. When all the field coils on a dynamo or motor run warm how can they be made to run cooler?

30. What is the cause of the humming noise sometimes heard in machines with iron-clad armatures?

## CHAPTER XVII.

### ARC AND INCANDESCENT LAMPS.

A large part of the electric power which is produced at the present time is used for electric lighting. To produce this light two devices are used; one is called the incandescent lamp, the other the arc lamp. In the incandescent lamp a comparatively small amount of current is forced through a thin carbon wire of very high resistance. This carbon wire is enclosed in a glass bulb which is completely exhausted of air and is supposed to contain nearly a perfect vacuum.

The object of extracting the air is two-fold: First, if any oxygen were left inside the bulb, the carbon when at a high temperature would greedily combine with all the oxygen in the globe, or the filament would burn up. Another reason why a vacuum is desirable is that if there were gases inside the bulb the heat of the filament would be more readily dissipated, because the particles of gas would be heated very much by contact with the incandescent carbon filament and then pass to the glass walls of the bulb, and give up their heat to it, and then return to the filament to be re-heated. In other words, if there were gases in the bulb, the incandescent filament would lose its heat through both radiation and conduction. When all the gases are exhausted from the bulb the only loss is the loss by radiation.

The current is brought to the carbon filament by two platinum wires which are melted into the glass. It is necessary to use platinum wire for this purpose, for the reason that platinum and glass expand with rise of temperature at about equal rates; all other metals expand about twice as rapidly as glass does, and contract twice as fast, so that if iron wires were fused into the glass at a high temperature, a small space would be left between the wire and the glass when the wire was cold, through which the air could slowly creep and spoil the vacuum.

The light given off by an incandescent lamp increases very rapidly with the temperature. A lamp on 100 volts is nearly as hot as when at 110 volts, but only gives about half the light.

It is desirable to work the lamps at as high a temperature as possible, in order to get as much light as possible out of them, but the higher the temperature or voltage at which they are worked the sooner they burn out.

A lamp may give a very good light at 110 volts and last for 600 hours that would not last 100 hours on 112 or 113 volts. A very necessary condition to the long life of an incandescent lamp worked at a very high temperature is that the voltage be constant.

Therefore, for the successful operation of high efficiency lamps, or those in which the carbon filament is very hot, a very steady and unvarying voltage is essential. The most common incandescent lamp produces about 16 candle power, is operated at 110 volts and requires from  $2\frac{1}{2}$  to 4 watts per candle or from 40 to 64 watts for the lamp. As an average, it may be said that each lamp takes  $\frac{1}{2}$  ampere at 110 volts,



or 55 watts; that is, about  $3\frac{1}{2}$  watts per candle. As the incandescent lamp gets old the light that it produces gets weaker until it becomes so poor a device for transforming electric energy into light that it pays to take the lamp down and substitute a new one.

It is likely that some time the heat in the filament of an incandescent lamp will be used as the heat from the gas is in a Welsbach gas burner, to heat an oxide that has the faculty of giving off a great deal more light at a low temperature than carbon has. If this could be successfully done it would very greatly increase the light produced by the incandescent lamp.

The arc lamp is best adapted for lighting streets or large areas in an interior. In the arc lamp a small part of a pencil of carbon is heated intensely by the passage of a considerable current from one pencil to another across an air space. The carbon is heated to about 7000 degrees F. until it probably vaporizes, and this very high temperature produces the most intense light that is known.

The ordinary incandescent lamp requires  $3\frac{1}{2}$  watts per candle power.

A current of 10 amperes at 45 watts produces 2000 candle power in an arc lamp, or about  $4\frac{1}{2}$  candle power per watt.

The objection to the arc light is that it is so intense that it casts deep shadows and dazzles the eye. This difficulty has been partly overcome in the enclosed arc lamps that are coming into such general use.

In these lamps the arc is produced in a glass globe that is arranged so that very little fresh air can get in.

The oxygen in the globe is very soon consumed by the carbon and the carbon thus burns away much more slowly than it would in the open air.

The arc lamp must be provided with automatic mechanism that will feed the carbon down as fast as it is consumed and so keep the arc the same length. The mechanism for accomplishing this result in the old lamps was in some cases quite complicated, but in the modern lamp there is very little mechanism.

In general, the operating mechanism of an arc lamp is composed of a magnet that grows weaker as the arc gets larger, and at a certain point grows weak enough to release a clutch that allows the carbons to come closer together.

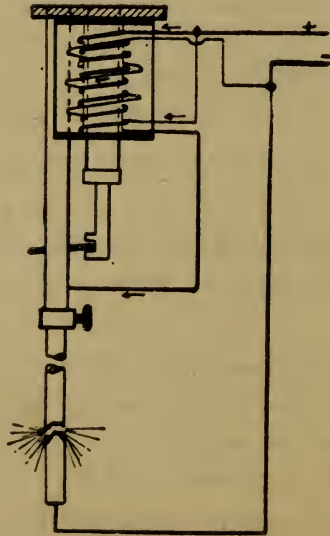

Figure 69  
Diagram showing action of series arc lamp,

Before the carbons can drop together the current through the lamp is changed and the magnet strengthened and the motion of the carbons arrested, and they are drawn a proper distance apart.

Figs. 69 and 70 are diagrams that illustrate the action of the series lamp and the modern constant potential lamp.

In the series lamp, in which the strength of the current is constant, the strength of the magnet is varied by using a series coil and a shunt coil in opposition to it. The shunt coil is connected across the arc and when the arc is long the current in this coil is great and the strength of the combined series and shunt coils is small, thus allowing the carbons to drop together.

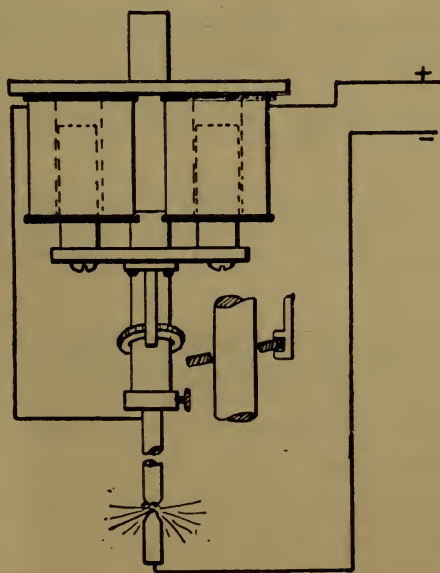

Figure 70

Diagram showing action of constant potential arc lamp.

## QUESTIONS ON CHAPTER XVII.

1. How is the light produced in an incandescent lamp?
2. Why is a vacuum necessary in the bulb of an incandescent lamp?
3. Why is it necessary to use so expensive a metal as platinum to carry the current to the carbon filament through the glass?
4. What is the necessary condition of the voltage of supply to produce a bright light and a long life in an incandescent lamp?
5. How many watts are used in an ordinary 16-candle power incandescent lamp?
6. When does it pay to destroy an incandescent lamp and substitute a new one?
7. What is the temperature of the electric arc?
8. How many watts per candle power are required in an arc?
9. Why do the modern inclosed lamps give better illumination but less light than the old style open arcs?
10. Why do the inclosed arc lights burn so much longer than the open arcs?
11. Describe the feeding mechanism in a constant current arc lamp.

## CHAPTER XVIII.

### MEASURING INSTRUMENTS.

There are a great many instruments used for measuring various electrical quantities, but all that can be considered in this chapter are volt meters and ammeters of the more common type.

Common volt meters are really ammeters with a very high resistance in circuit and so arranged that the current which passes through them is proportional to the voltage; therefore what the meter actually measures is the amount of current that passes through it, but as the current is proportional to the voltage, the movements of the measuring instrument may be made to read volts direct.

Fig. 71 is a diagram showing the way in which a Weston meter is constructed. This is an excellent illustration of the fundamental fact on which the operation of motors depends.

A permanent magnet *M* causes magnetic flux to flow across the gap *G*; situated in this gap is a bobbin *B*, on which are wound a number of turns of copper wire. The bobbin is made of copper and is arranged to revolve on jewel bearings. Two springs *S*, one above and one below the bobbin, carry the current from the movable bobbin to the stationary part of the meter. If current is now passed through the bobbin by way of the springs, the current will

flow downwards on one side of the bobbin and upward on the other side. Thus the current in both sides of the bobbin produces a torque which moves the bobbin against the force of the two hair springs *S*. The bobbin will continue to move until the torque exerted by the current equals the counter-torque exerted by the two springs. A pointer registers the amount of motion and the position of the pointer is read off as volts.

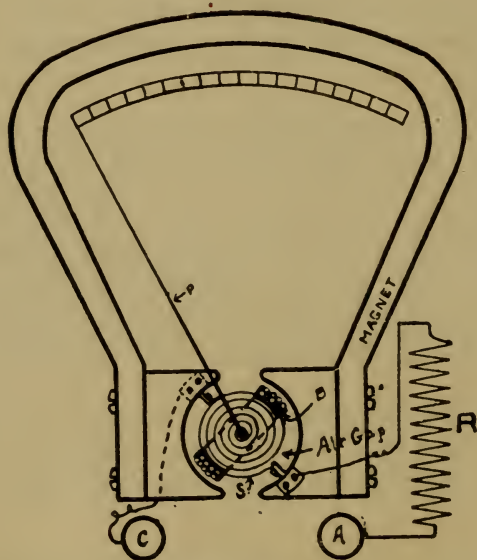

Figure 71

Diagram of connections and moving parts of Weston voltmeter.

A little examination will show that the torque exerted by the wires carrying the current on bobbin *B* is proportional to the current, for the flux is constant throughout the whole air gap. It is also true that the counter-force exerted by the two hair springs is proportional to the move-

ment of the bobbin; therefore twice as much current in the wires on the bobbin will produce twice as much movement of the pointer over the scale. The magnet M is made of Tungsten steel and is artificially aged, so that when the instrument is turned out of the factory the magnetizing power of the magnet will remain constant for years.

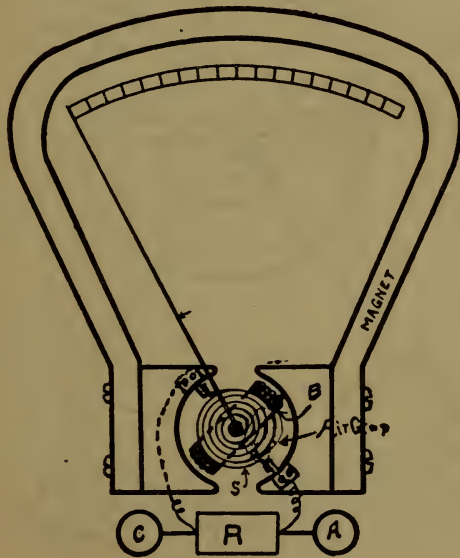

Figure 72  
Connection of Weston ammeter.

Current is brought into the instrument through the binding posts A and C, but, before passing through the wire on the bobbin, the current must traverse the very high resistance R; this resistance is from 65,000 to 75,000 ohms for a volt meter intended for a 600-volt circuit. Therefore the

current which passes through the wires on the bobbin, even with full voltage, is very small, and with 100 volts will be not much over 1-700 of an ampere. Yet this small current is able to produce very considerable deflection in the two hair springs which resist the motion of the bobbin. Another very excellent point in the design of this meter is the

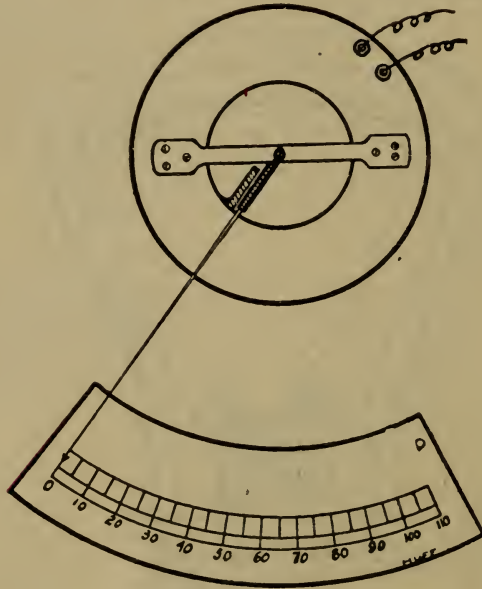

Figure 73

Magnetic vane voltmeter depending on repulsion of two similarly magnetized iron strips.

way in which it is made deadbeat, or the way in which the needle is prevented from vibrating back and forth on each side of the point at which it will finally come to rest. The bobbin B is made of copper, and when it moves there will be generated in it currents which, according to Lenz's law, tend



to prevent its motion. The mechanical momentum given to the bobbin by the action of the current in the wires that are wound on it is absorbed by these Foucault or eddy currents in the copper bobbin. The Weston direct current meters are almost perfectly deadbeat.

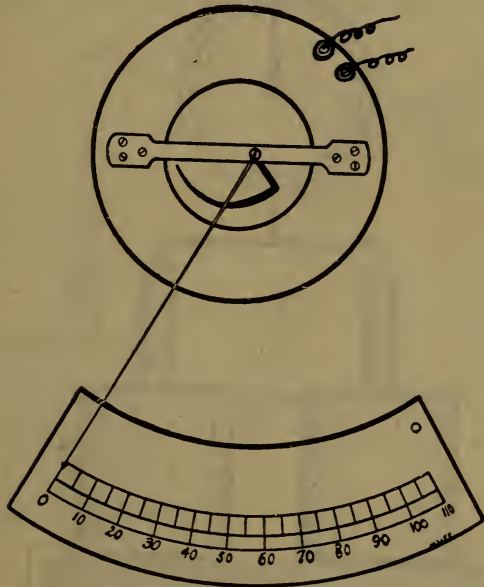

Figure 74

Western electric meter depending on effort of iron strip to get into as powerful field as possible, or to get as near to the wire carrying current as possible.

In Fig. 72 is a sketch of the Weston direct current ammeter. The working parts are precisely the same, the principle of operation is identical, and it would be impossible to tell the two instruments apart, so far as the actual indicating mechanism is concerned, if it were not that the bobbin is wound with coarser wire.

The wire on the bobbin is a shunt on the resistance  $R$ . The whole current to be measured passes through the meter from binding post A to post C. In doing so it has to pass through the resistance  $R$ . The voltage at the extremities of this resistance is, according to Ohm's law, proportional

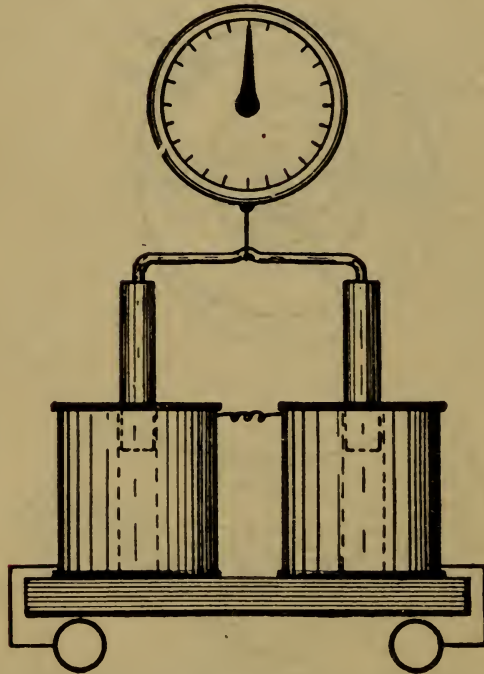

Figure 75

Brush Electric Co. voltmeter and ammeter in which the attraction of a Solenoid for an iron core is weighed.

to the current; or, looking at it in another way, the current will divide between the resistance  $R$  and the bobbin  $B$  inversely proportional to their resistances. Therefore, when a large current is passing through  $R$ , a correspondingly large current is passing through bobbin  $B$ . As we have

seen in Fig. 71, the position of the pointer registers the amount of current passing through the bobbin, and it will be seen that the position of the pointer may be read off directly as amperes.

A large class of the cheaper measuring instruments depend for their action upon the attraction of a solenoid for

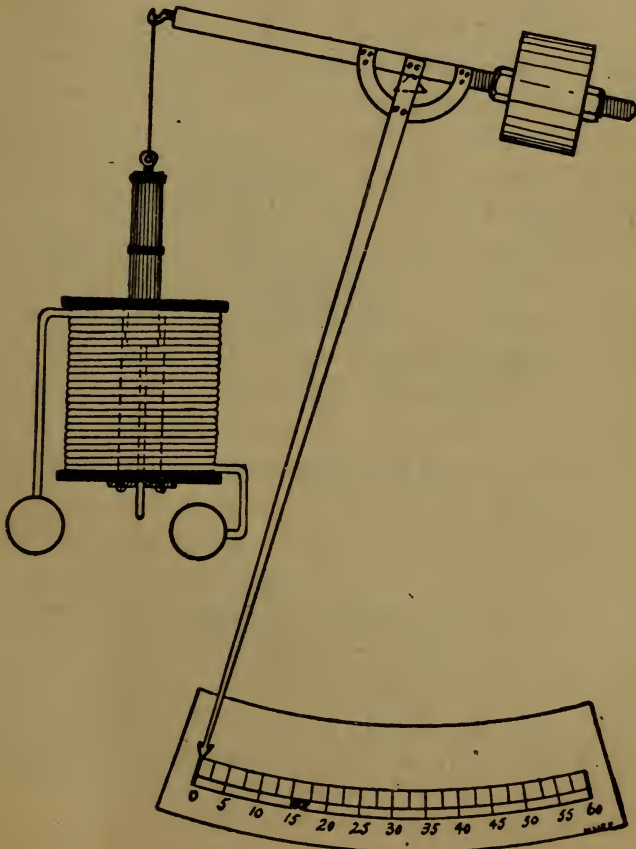

Figure 76

Westinghouse voltmeter and ammeter showing laminated core for Solenoid. This is adapted for alternating currents.

a piece of iron. The attraction of the solenoid is balanced by a spring or gravity and the position at which equilibrium occurs is a measure of the attracting force, and therefore a measure of the ampere turns in the solenoid. Whether the position of the pointer is to be read off as volts or amperes depends on whether the coil is wound with fine wire or coarse wire.

A serious objection to these instruments in so far as their accuracy is concerned, is that they will record higher values on descending amperes or volts than on ascending. This is due to the residual magnetism. When a current of 25 amperes would pass through the meter this would cause a certain number of lines of force to pass through the iron part of the meter. When the current sank to 23 amperes a certain number of lines due to the 25 ampere current would still remain in the iron, and this number would be greater when the current would pass from 25 amperes to 23 amperes than when it passed from 21 to 23 amperes. The mechanical force acting on the iron would be greater in the first than in the second case and therefore the amperes indicated will be higher. Error due to this cause amounts to from 2 to 10 per cent., depending on the construction of the meter. Fig. 73 shows one style of magnetic vane meter. Fig. 74 shows the meter built by the Western Electric Co. Fig. 75 shows a style of meter formerly built by the Brush Electric Co. Fig. 76 shows the type of meter built by the Westinghouse Electric Co.

## THOMPSON RECORDING WATT METER.

Most of the recording meters in use in this country are of this type. In general, the meter is simply an ordinary motor, except that it is built without iron, as shown in Fig. 77. Attached to the shaft of this motor is a retarding disc, which is made of copper and is revolved between permanent field magnets. The field coil in this meter is usually made of coarse wire, and through it passes the current to be measured. The armature is wound up with fine wire

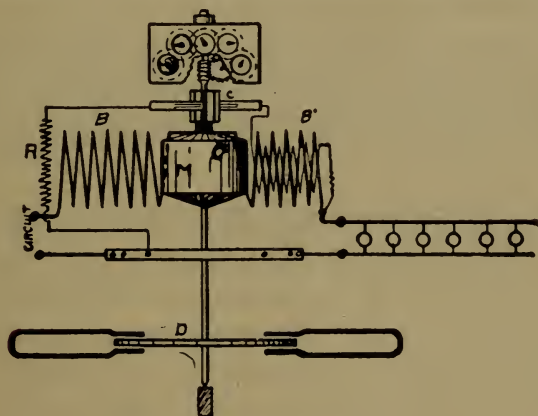

Figure 77

Diagram of connections and operation of Thompson's recording wattmeter.

and is connected up to a small commutator composed of silver bars. Two thin silver brushes touch this commutator and carry the current to and from the armature. The torque on the motor is proportional to the product of the current in the fields and armature. In well regulated systems, the voltage supplied is so nearly constant that the current in the armature is practically the same for any load.

It should be remarked that, in order to reduce the current wasted in passing through the armature to the smallest possible amount, there is in series with the armature a very large external resistance. The voltage supply being practically constant, the current through the armature will also remain constant. The only factor that varies much is the current in the field. Eddy currents are generated in the copper disc by its motion between the poles of the permanent magnets, and doubling the speed doubles the voltage produced and therefore doubles the current or quadruples the watts lost in the disc.

In order to make the instrument register correctly, the speed must be twice as great when 20 amperes are passing through the field as when only 10 amperes are passing through.

Doubling the current through the field doubles the magnetic field through which the armature revolves, and this doubles the torque on the armature. Doubling the speed doubles the current produced in the retarding disc, so that the increased torque is balanced by an equally increased resistance or counter torque in the disc. If the armature speed is doubled its counter electro-motive force will be quadrupled, because it is revolving at double speed in a field of double strength.

Since in any case the counter electro-motive force is extremely small, the current passing through the armature is not varied appreciably by the variation in the counter electro-motive force. We have then, by doubling the speed, quadrupled the watts lost in the revolving copper ring and at the same time have quadrupled the energy imparted to the armature by quadrupling its electro-motive force

against a constant current. Since these same relations always hold, it is clear that the speed of the instrument will be always proportional to the current passing through it. Consideration will show that a change in the voltage while the current remains constant will change the counter electromotive force of the armature and its speed in the same way that change of current does.

If the voltage alone should change and the current be constant, the same relation is true. Suppose the voltage to be doubled; the current through the armature would be doubled and there would be twice the torque on the armature. This double torque would produce double speed and consequently double counter E. M. F. acting against double current, or it would exert four times as much energy as at the lower speed.

Thus, for either case of change of voltage or current the speed of rotation is a correct measure of the energy passing through it.

## QUESTIONS ON CHAPTER XVIII.

1. What does a common volt meter really measure?
2. On what law does the accuracy of the common volt meter depend?
3. If, in Fig. 68, the right-hand pole is north, which way does the current flow through the right-hand side of the bobbin when the needle registers voltage?
4. What makes the Weston volt meter dead beat?
5. What is the object of the iron core between the poles of the horse-shoe magnet?
6. When the meter registers the voltage and comes to rest, what two forces are equal?
7. On what does the permanent accuracy of this meter depend?
8. What is the difference between the Weston ammeter and volt meter?
9. Describe the electrical connections in the ammeter.
10. Describe the action of the magnetic vane instrument.
11. What is the objection to measuring instruments using soft iron?
12. Why is the speed of the Thompson recording meter proportional to the watts in the circuit to which it is connected?
13. If the voltage of the circuit supplying the current is constant, and the power required to rotate the copper disc is proportional to the square of the speed, why will doubling the current double the speed?



## CHAPTER XIX.

### ALTERNATING CURRENTS.

The currents that have been previously considered in this work have been direct; that is, constantly flowing in one direction. An alternating current is one which changes its direction many times every second; that is, the current flows first in one direction and then in the opposite, the time required for alternation or reversal varying from 1-50 to 1-275 of a second. In the older lighting dynamos the number of alternations usually employed was from 250 to 266 per second. Modern alternating current machinery operates from 50 to 125 alternations per second.

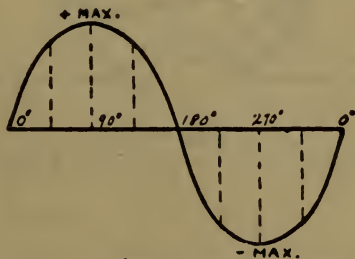

Figure 78

Two successive alternations or one cycle.

Fig. 78 is the diagram of two successive alternations in a circuit. Two successive alternations, such as shown in this figure, are called a period or a cycle. A two-pole machine will produce one cycle every revolution. Fig. 79

shows a bi-polar dynamo with a single coil wound on it, with the two ends of the coil connected to a pair of rings on which brushes make contact. As this coil revolves between the poles of the dynamo there will be a certain E. M. F. produced at each point. The E. M. F. will be a maximum when the coil is horizontal and the plane of the coil and plane of the poles coincide. From this point on the voltage decreases gradually until the coil is vertical, and at this point becomes zero. As the coil moves on voltage is

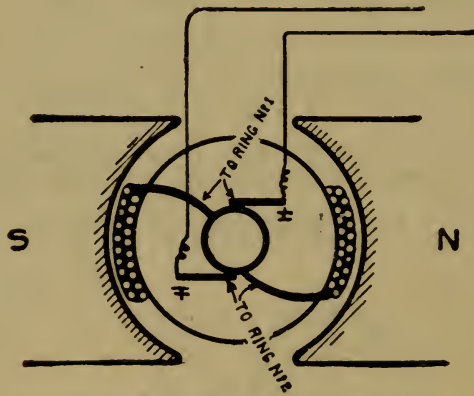

Figure 79  
Alternating current produced in a bipolar field.

again generated, but now in the opposite direction. When the coil reaches the horizontal position the voltage will be a negative maximum, which gradually diminishes until the coil has reached the vertical position again and the voltage sunk to zero. The voltage will now be produced in a positive direction and again increased to a maximum.

A cycle is usually considered to begin at the point at which the voltage is at zero and at which the current which is to be generated in the next half revolution will be positive.

Fig. 80 shows a coil revolving in a uniform field. Such a coil will generate what is known as a sine wave; this is the form of the current wave that is sought in all power transmitting machinery. Fig. 78 shows the sine wave.

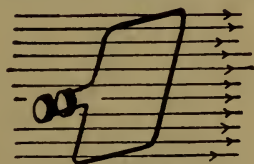

Figure 80

Coil revolving in uniform field and producing a sine wave.

The old Westinghouse alternating current dynamos used for lighting were run at 133 cycles per second. The Thompson-Houston were run at 125 cycles per second. Most of the modern alternating current machinery is run at 7,200 alternations per minute, or 60 periods per second. The great plant at Niagara Falls, which transmits power to Buffalo, runs at 3,000 alternations per minute, or about 25 per second. An ordinary alternating current is called a single phase current. Such a current as would be generated in the mechanism shown in Figs. 79 and 80 would be a single phase current.

A two-phase current is really not one current, but two separate currents produced from one dynamo. One of these currents succeeds the other in such a way that when the first current is at a maximum the other current is at zero; in other words, they are a quarter cycle apart.

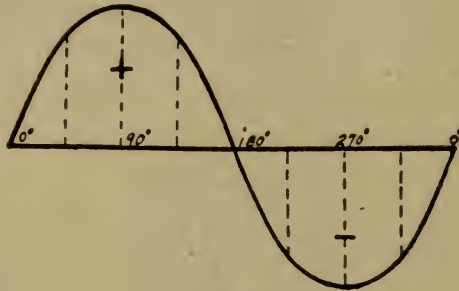

Figure 81  
One current of a two phase current.

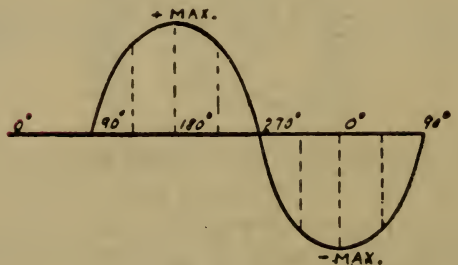

Figure 82  
The other current in a two phase current.

Fig. 81 shows one of the currents in a two-phase dynamo; Fig. 82 shows the other. Fig. 83 shows the two combined in one diagram. Fig. 84 shows a way in which a two-phase current may be taken from a direct current commu-

tator. It will be seen by an examination of Fig. 84 that the two currents which are taken from the commutator of the two-pole dynamo are connected to bars which are 90 degrees apart; thus when the current in circuit No. 1 is at zero, the commutator bars to which it is attached are on a horizontal line and there is no difference of voltage between the

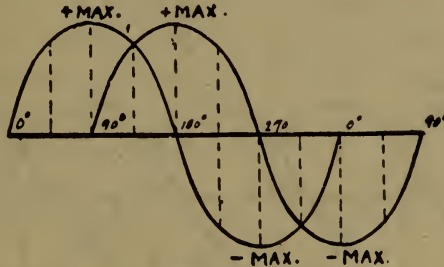

Figure 83

Diagram of two phase currents or Figures 81 and 82 on one diagram.

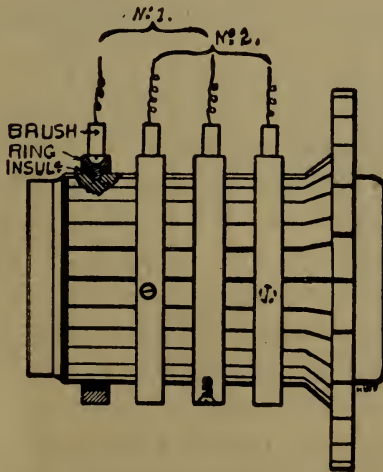

Figure 84

Method of producing two phase current from the commutator of a bipolar armature.

two bars, and therefore there is no current in the circuit. The circuit No. 2 is attached to bars which are in a vertical line, and the voltage between these bars is at a maximum. Fig. 84 makes it clear why it is that the two currents in a two-phase circuit are said to be 90 degrees apart. A three-phase current is one in which, there are three currents, but they can hardly be called three separate currents. If the

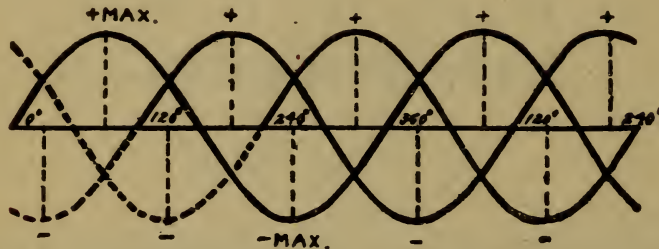

Figure 85

A diagram of the currents in a three phase line.

three sliding rings shown in Fig. 86 be connected to three commutator bars 120 degrees apart on the commutator of a two-pole dynamo, the current which is taken from these three sliding rings is a three-phase current, as shown in diagram in Fig. 85. Thus, if there were 36 bars in the commutator of a two-pole dynamo, one slide ring would be attached to commutator bar No. 1. The second slide ring will be attached to commutator bar No. 13 and the third slide ring would be attached to commutator bar No. 25; or, each slide ring is attached to a point 1/3 the circumference of the commutator away from its neighbor. Since there are 360 degrees in a circle, these currents are said to be 120 degrees apart. If a two-phase current were

to be taken from this same commutator, circuit No. 1 would be attached to bars Nos. 1 and 19; circuit No. 2 would be attached to bars Nos. 10 and 28. By a proper combination of two-phase or three-phase currents it is possible to produce a revolving pole. By placing inside of the apparatus which produces this revolving pole a short circuited armature, this will be dragged around by the revolving pole in the same way that a short circuited armature in a direct current machine would be dragged around if the fields were revolved about such an armature. Such a machine is called an induction motor.

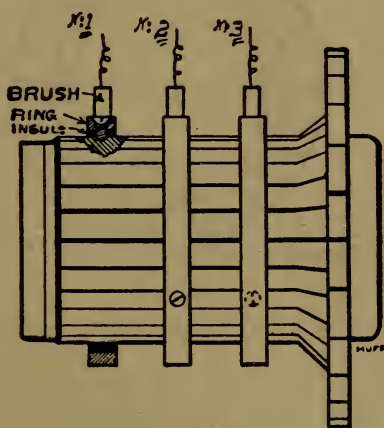

Figure 86

[Method of producing three phase current from the commutator of a bipolar armature.

The great advantage that alternating currents possess over direct currents is that they can be transformed from a low voltage and a large current to a high voltage, and small current without any moving mechanism, or vice versa.

Alternating current is usually generated for lighting purposes in a dynamo at from 1,000 to 2,000 volts. A small current at this high voltage will transmit a large number of watts, and only small wires will be needed to transmit this small current; one ampere, for instance, of this current at 1,000 volts is received in the primary coil of a transformer, which changes it into 10 amperes at 100 volts, or 20 amperes at 50 volts, depending upon the winding of the transformer. This low voltage current is distributed

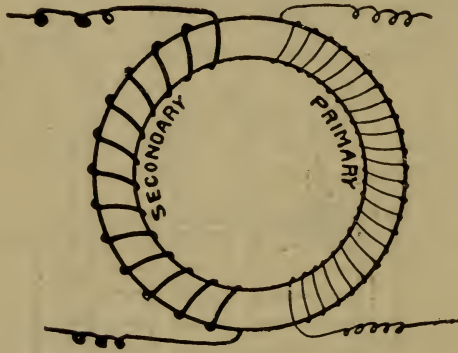

Figure 87  
Diagram of alternating current transformer.

through the building to be lighted and operates 20 incandescent lamps. Fig. 87 is a diagram of a transformer; P is the primary coil which receives the high voltage current, S is the secondary coil which delivers the low voltage current, I is an iron core passing through both coils. According to Lenz's law, current will be generated in the secondary coil in opposition to that of the primary. The number of turns on the primary and on the secondary coils is in the ratio of their voltages. Thus, if there are 100 turns on the primary coil and it is designed to receive current at 1,000



volts, there will be five turns on the secondary coil if it is desired to have it deliver current at 50 volts.

The transformers are connected in parallel across the main circuit and the self-induction of the primary coil prevents excessive current from flowing through it when the secondary circuit is open. Thus, suppose current is supplied at 125 periods per second and that there are 100 turns on the transformer and that 2,000,000 lines flow through the core of the transformer on an average. A little study will show that the voltage produced in a coil having 100 turns placed around this iron core would be

$$100 \times 125 \times 4 \times 2,000,000$$

---

$$100,000,000$$

Solving this equation, we find that there will be 1,000 volts produced in such a coil.

If 1,000 volts would be produced in a separate coil, there must be the same voltage produced in the coil which is attached to the 1,000 volt line wires. In this coil the voltage will appear as counter electro-motive force opposing the voltage of the main circuit. This E. M. F. is almost precisely equal to the E. M. F. on the large line wires, and, in fact, the only current that leaks through the primary coil is just enough to produce ampere turns sufficient to cause 2,000,000 magnetic lines to flow through the iron core of the transformer.

When the secondary circuit is closed, however, the current in it tends to de-magnetize the iron core, because, according to Lenz's law, it flows in the opposite direction to that in the primary coil. There will be, therefore, a certain number of counter magnetizing turns due to the current in the secondary coil, and there must be always

just enough more magnetizing turns in the primary coil to overcome the de-magnetizing turns in the secondary coil and still force the magnetic flux through the iron core, and so produce the counter E. M. F. in its own coils sufficient to oppose the E. M. E. of the main line.

It will be noted that the transformer receives and delivers the same number of watts, but that this number of watts may be made up volts and amperes in almost any ratio that we please by properly choosing the number of turns on the two coils. The Ruhmkorff coil is an example of this, in which a battery current of a few volts and eight or ten amperes is transformed into an exceedingly small current, but having a voltage of hundreds of thousands of volts. It is to be kept in mind that the battery current is interrupted or, in effect, made alternating by the circuit breaker on the coil. The alternating current system of transmitting power is without doubt destined to come into very extensive use on account of the ease of transformation with a transformer without any moving parts and on account of the cheapness of the line over which the power can be efficiently transmitted after being transformed with such little expense. Lines are in use in this country in which power is transmitted 40 miles at a pressure of 40,000 volts. In an experimental plant in Germany power was transmitted 130 miles with a loss in the line amounting to only 13 per cent. Without doubt power electrically transmitted by alternating currents of high voltage is destined to play a very large part in the industrial development of this country.

## QUESTIONS ON CHAPTER XIX.

1. What is an alternating current?
2. How many alternations per second were used in the older lighting systems?
3. What is a period?
4. A four-pole machine is running 1,100 revolutions per minute; if it is producing alternating current, how many cycles per second will this current have?
5. How may an alternating current be produced from an ordinary direct current motor or dynamo?
6. What is a sine wave?
7. What is a single phase alternating current?
8. What is a two phase alternating current?
9. If a two phase current is taken from a direct current two-pole dynamo, to what points on the commutator will the four rings be attached?
10. What is a three phase alternating current?
11. How may a three phase current be produced from a direct current two-pole dynamo?
12. Why are the currents of a two-phase current said to be 90 degrees apart, while the currents of a three-phase current are said to be 120 degrees apart?
13. If possible, sketch the connections which would be necessary to produce a revolving pole with a two-phase current.

14. What advantages do alternating currents have over direct currents?
15. What is an alternating current transformer?
16. What is the object of a transformer?
17. How is current produced in the secondary coil from a primary coil with insulation of thousands of ohms between the two coils?
18. Why will a transformer connected across a thousand-volt circuit and having a resistance of only one ohm allow only a small part of an ampere to pass?
19. Why will the current in the primary coil increase when the resistance of the secondary circuit decreases?
20. What is true of the watts received by the primary coil and the watts delivered by the secondary coil?
21. What is a Rhumkorff coil?
22. Why is the alternating system of power transmission rapidly coming into use?

## ANSWERS TO QUESTIONS ON CHAPTER I.

1. Nothing of its ultimate nature.
2. They are probably better understood than the laws governing heat and light.
3. The operation of an hydraulic system.
4. (a) The water pressure or head. (b) The amount of flow or number of gallons per minute. (c) The frictional resistance of the pipes carrying the water.
5. The volt.
6. To one foot of head or pressure.
7. The ampere.
8. The ohm.
9. Amperes equal volts divided by ohms.
10. Ohm's law is only the application of a general law to electrical action. The flow of heat through a wall is an example.
11. About two.
12. Usually 110.
13. (a) One-half ampere. (b) From six and a half to ten.
14. One ohm.
15. Loss of pressure between boiler and engine in steam pipes.

16. On the amount of fluid carried through the pipe and on the straightness and general character of the pipe line.

17. To the dynamo.

18. To be filled in by student.

19. Upon the amount of current transmitted and on the resistance of the wire.

20. Draw a diagram and compare with Fig. 4.

21. From 95 to 98 per cent.

22. It is the loss of voltage due to the resistance of the wires over which the current must travel.

23. The use of wires of such size that the loss of voltage shall be practically zero.

24. On account of the great size of conductors needed and the consequent expense.

25. To select wire of such size that the lamps shall at all times receive the same voltage.

26. See text, page 8.

27. No. (2).

28. Write out and compare with text.

29. Four volts.

30. Such a circuit would require 800 feet of No. 0000 wire.

31. Fifty amperes.

32. .077 ohms.

33. 108 volts.

34. 12,100.
35. About two volts.
36. Wire twice as large as No. 0000.
37. So as to reduce the drop to as small an amount as possible.
38. \$806.00.
39. When only a few lamps are burning on a distant circuit, the voltage on this circuit is practically that of the dynamo, and tends to burn out the lamps.
40. Table 2, page 16.
41. At least 50 volts.
42. Through the rails and ground.
43. Because the copper used in bonding the track is not nearly so great in amount as that required by the trolley wires and feeder.
44. 2.59 times the size of a No. 0000 wire.
45. \$1,900.00.
46.  $\frac{125}{75} \times 500$  equals 833.
47. \$1,141.00.
48. No. 1 or No. 0.
49. Such a system would leave the trolley wire disconnected near the power house. Power would be supplied to the line from the dynamos by feed wires connected at a distance from the power station.

50. By the constant potential and constant current systems.

51. For operating the older arc lamp systems.

52. Each device for receiving electricity is exposed to the same electro-motive force.

53. Each device for receiving electricity must carry the same current.

54. From  $9\frac{1}{2}$  to 10 amperes.

55. About  $6\frac{1}{2}$  amperes.

56. The resistance of the wire in ohms equals 10 8-10 times the length in feet divided by the square of the diameter of the wire in thousandths of an inch.



## ANSWERS TO QUESTIONS IN CHAPTER II.

1. Galvani and Volta.
2. Write the answer and compare with the text.
3. From the negative plate through the outside circuit to the positive plate.
4. The chemical action of the electrolyte upon the positive plate.
5. The counter electro-motive force caused by the production on the negative plate of some gas, usually hydrogen.
6. The positive element is the one on which the electrolyte acts chemically; the negative element is the remaining one upon which the electrolyte has less or no chemical action.
7. The terminal on the negative plate from which the current flows into the outside circuit.
8. Platinum, carbon and silver.
9. Because zinc and carbon are farther apart in the electro-chemical series than zinc and copper.
10. Both mechanical and chemical means are employed. The mechanical means consists of blowing air or some other gas across the negative plate, or of providing numerous small points from which the gases may escape.
11. Write the answer and compare with text.
12. They cost too much.

13. Write description of Jablockoff battery and compare with text.

14. Write description of plunge battery and compare with text.

15. It should be amalgamated.

16. Directly proportional.

17. An instrument in which the amount of current that has passed in a given time is measured by the amount of decomposition effected.

18. Write answer and compare with text.

19. An anode is the plate or electrode by which current enters the solution. A cathode is the plate or electrode by which current leaves the solution.

20. With it.

21. Write answer and compare with text.

#### ELECTRO-PLATING.

1. Metal is taken from the anode and deposited in a thin even layer on the cathode or work to be plated.

2. See text.

3. On the ampere hours or on the amount of current flowing multiplied by the length of time it flows.

4. The work is burned.

5. Yes. See text.

## STORAGE BATTERIES.

1. A storage battery is one in which electrical energy is consumed in producing chemical change and which will return the energy so stored as electrical energy upon demand.

2. See text.

3. It does not polarize, has a very low resistance, and so is capable of producing heavy discharges, and has a higher voltage than most primary batteries.

4. For running horseless carriages and electric launches, and for absorbing the energy of a dynamo or circuit at times of light load and restoring it at times of heavy load. A battery may be very advantageously placed at or near the end of a long feeder line, so as to make the current that flows over the line nearly constant.

## ANSWERS TO QUESTIONS ON CHAPTER III.

1. It is magnetized.
2. A small magnet is supported in such a manner as to be free to turn in a horizontal plane.
3. A north pole is one that points to the geographical north. A south pole is one that points to the geographical south.
4. The region of magnetic influence surrounding the poles of a magnet.
5. From the north pole into the air into the south pole and through the iron to the north pole.
6. The figure formed usually by iron filings in a field of magnetic force, showing the direction and intensity of magnetic force.
7. It is much more concentrated than that of a bar magnet.
8. See text.
9. The circular and concentric lines surrounding a wire carrying a current.
10. The same as between the direction of rotation of a right hand screw and its direction of motion forward or backward.
11. Up.
12. South.
13. North.

14. A piece of magnetic metal around which a current is circulating.

15. See text.

16. That end of an electro-magnet around which the current circulates in the direction of motion of the hands of a watch, as seen by the observer, is the south pole.

17. Yes. The lines of force flowing from the electro-magnet may be considered as the sum of the magnetic whirls of the wires which surround the core.

18. A coil of wire in which a current flows. It is a weak magnet.

19. An electro-magnet without a metallic or iron core would be a helix.

20. It experiences a mechanical force that pulls it sideways across the magnetic lines.

21. Current and field in proper relation are supplied and motion results.

22. Motion and magnetic field properly related are supplied and electro-motive force which may produce a current is the result.

23. Thumb, first and second fingers of the right hand are extended at right angles to each other, and point in the directions respectively of motion, lines and current.

24. Extend the thumb, first and second fingers of the left hand at right angles to each other, and they will point respectively in the directions of motion, lines and current.

25. Because the direction of lines would be reversed without reversing anything else.

26. The wire on top moves in one direction, the wire on the bottom in the opposite direction, both of which tend to produce rotation in one direction.

27. Current will tend to flow from the top to the bottom of the wheel.

28. Current will flow in the direction of the hands of a watch, as seen by the observer on the south side of the loop.

29. Current will flow from east to west.

30. Current flows away from the observer.

31. About 1-10 of a pound per foot.

32. 100,000,000.

33. Yes. To provide sufficient friction between the wire and the armature core to prevent the wires moving from the mechanical force exerted between the current in the wire and the magnetic field.

## ANSWERS TO QUESTIONS ON CHAPTER IV.

1. On the ampere turns.

2. Yes. The relation between magnetic flux, ampere turns or magnetic motive force and magnetic reluctance is the same as that between current, electro-motive force and electric resistance, as given by Ohm's law.

3. The flux corresponds to the current, the ampere turns or magnetic motive force to the electro-motive force.

4. Directly proportional to the length of the circuit and inversely proportional to its area.

5. It multiplies the number of lines passing through the helix.

6. Because all the magnetic lines must pass through the center of the helix and the area is restricted while the return path for the magnetic lines outside the helix is practically unlimited.

7. Flux equals ampere turns x area divided by length

$$\text{x.3132 equals } \frac{1425 \times 7.07}{5\frac{1}{2} \times \text{x.3132}} \text{ equals 5850.}$$

21

8.  $\frac{21}{15} \times 5850$  equals 8190.

15

9. The multiplying power of a magnetic metal for magnetic lines.

10. Because the permeability is not constant.

11. When it is carrying a great many magnetic lines.

12. It is said to be saturated.

13. In order to reduce the magnetic reluctance sufficiently to allow enough lines of force to pass to produce the proper E. M. F.

14. By comparing the number of magnetic lines that actually do flow through iron with the number that would flow through the same space occupied by air.

15. They are about equal.

16. It is a representation of one sample, but only approximately represents the class.

17. Wrought iron has about twice the permeability of cast iron.

18. Because the permeability of each part is different and it is easier to get the desired result by making the separate calculations.

19. 3371.

20. A. t. in air gap.....	2595
A. t. in body of teeth.....	100
A. t. in neck of teeth.....	103
A. t. in armature .....	495
A. t. in pole piece .....	22
A. t. in yoke .....	56



21. A. t. in air gap,	2770
A. t. in body of teeth,	240
A. t. in neck of teeth,	200
A. t. in armature,	38
A. t. in pole piece,	49
A. t. in yoke,	105

22. Because the larger number of ampere turns is expended in the air gap and an error in this calculation would make a great difference in the result, while the same error in the calculation of the yoke, for instance, would not make nearly the same difference.

23. About one-half.

$$24. \text{ A. t. equals } \frac{1,000,000 \times 37.68 \times .3132}{9.62 \times 309} \text{ equals } 3970.$$

25. Nickel and cobalt.

26. No.

27. One in which the wire is wound on the surface.

28. They give mechanical support to the armature wires and greatly reduce the reluctance of the air gap.

29. The lines tend to pass from the surface of the pole piece in tufts or bunches.

$$30. 12 \times (.310 + .062) \times 5 \text{ equals } 22.32.$$

$$31. \text{ A. t. equals } \frac{5000 \times 1 \times .3132}{\frac{1}{2} \times 4} \text{ equals } 783.$$

32. From 125,000 to 140,000 lines per square inch.

33. It will reduce the flux six or eight per cent. The exact amount of reduction could only be determined by making several guesses and figuring out each one. If we assume that it will decrease the flux 6%, figure out how many a. t. would be required in the magnetic circuit for this number of lines, and, if not right, make a second or third.

34. Because the permeability of the air gap while great is constant, while the permeability of the iron part of the circuit depends very greatly on the amount of flux.

35. Because it is practically impossible to obtain exactly correct permeability values.

## ANSWERS TO QUESTIONS ON CHAPTER V.

1. One of the results of the flow of magnetic lines of force, usually exerted across an air gap between two pieces of iron.

2. About 1,000 pounds per square inch.

3. Because it increases the amount of flux across the air gap and does not produce enough to saturate the iron parts of the circuit.

4. Because the pull is proportional to the square of the number of lines per square inch, and if the same flux can be crowded down to a small area the total pull will be increased

5. The magnet will be one foot in diameter if it is to be as light as possible, for a given area of contact can be secured with less weight in a magnet of large diameter than with one of small diameter. The magnet is required to exert a pressure of 3,000 pounds. Assuming a pressure of 270 pounds per square inch, the contact area will be 11.11 or 5.55 on each side. The cross section of the magnetic circuit will

be 
$$5.55 \times \frac{14}{10} \text{ equals } 7.77.$$

Assuming a coil 1 inch by 2 inches, as in Fig. 33b, the outside diameter of magnet will be 12 inches. The thickness of the wall will be .2 inch to give an area of 7.77 square inches in each side. The outside diameter of inner ring will be 9.6, and the inner wall will be .26 thick.

6. Area of magnetic circuit equals  $2 \times 2 \times .7854$  equals 3.14.  
 Assume 100 turns on each coil: 33,000 lines must flow per square inch.

$$\text{A. t. equals } \frac{104,720 \times 2 \times .3132}{3.14} \text{ equals } 21,000.$$

Amperes in each coil equals 105.

7. Annular, as shown in Fig. 33a.

8. Sectional area of magnet equals 5.8 square inches, assuming a pull of 270 pounds per square inch. Thickness of outside wall is about 1-3 of an inch. Assume coil to be  $1\frac{1}{2}$  inch deep. Length of magnetic circuit equals about  $6\frac{1}{2}$  inches. A. t. equals  $6\frac{1}{2} \times 25$  equals 487. Add 300 a. t. for constricted portion of the circuit, or a. t. equals 787.

## ANSWERS TO QUESTIONS ON CHAPTER VI.

1. Magnetic lines that are produced but do not pass through that part of the circuit that they were intended to traverse.

2. From 15 to 800 times better than air.

3. By exposing as little pole surface as possible to the air and having rounded corners on what is exposed.

4. Because the surface at full magnetic difference of potential exposed to the air is so great in the Edison and so small in the internal pole.

5. About 8,800 through each slot.

6. About 64,000.

7. Because iron conducts magnetic lines a few hundred times better than air and copper conducts electric current millions of times better than air.

8. No; it only makes the magnet core and yoke heavier than they would otherwise be.

9. Magnetic leakage is apt to draw nails, oil cans, wrenches, etc., into the poles, when they may be entangled with the armature.

10. Small magnetic leakage and the removal of surfaces that would attract iron pieces from much chance of drawing anything into the armature.

11. The number of lines that pass through the field magnet core divided by the number that pass through the armature.

## ANSWERS TO QUESTIONS ON CHAPTER VII.

1. See formulae Nos. (8), (9) and (10) in text.

2. 746.

3.  $8 \times 500$  equals 4000.

4.  $\frac{5\frac{1}{2} \times 746}{110}$  equals amperes equals 37.3.

5. .0663.

6. 134.

7. 4.97 per cent.

8. No.

9.  $\frac{32}{55}$  amperes.

10. On 110 volts 6.782, on 220 volts 3.391, on 500 volts 1.492, on 1000 volts .746, on 10,000 volts .0746.

11. On 110 volts 9.09, on 220 volts 4.545, on 500 volts 2, on 1,000 volts 1, on 10,000 volts .1.

12. Because the voltage is higher and the current lower than if the dynamos were in parallel.

13. More economical because the voltage would be still further raised and the current reduced in the same ratio.

14. Because it permits of the use of a cheap line with only small loss of power.

15. It could not be accomplished with 250 volts.

16. It could not be accomplished with 500 watts. About 95 per cent of the 100 horse power would be lost in the line at 1,000 volts; 49 volts or 180 watts or  $\frac{1}{4}$  of 1 per cent. with 20,000 volts.

17. Because with the same copper cost the amount or weight used is the same, and if this is run two inches instead of one, the resistance of each mile is doubled and the miles of line are doubled, and therefore the resistance quadrupled.

18. As the square of the voltage.

19. The distance varies directly as the voltage.

20. 0000 wire is the nearest standard size, and this will cost \$506.40.

21. Three No. 000 wires can be used, and this will cost \$1,140.75.

22. The drop specified in this question should have been omitted, and then the current would be 123.3.

23. Because the armature generates voltage and when it is in operation there is no way of measuring what is used in the armature resistance. Therefore the other two formulae that contain the voltage lost cannot be easily applied.

## ANSWERS TO QUESTIONS ON CHAPTER VIII.

1. To know the length of the average turn.
2. See text.
3. 4129.
4. No. 17.
5. 32,400.

6. Because the number of a. t. is increased with the same size of wire if it is small in diameter, and a small wire and small power will therefore produce more a. t. if of small circumference than if of large.

7. In order to have section enough of iron to allow the magnetic flux to pass.

8. Because an increase in the amount of the wire decreases the current that flows through the coil in the same proportion that it increases the turns.

9. Yes. A heavy coil requires only a small amount of current to produce a given magnetizing power, and therefore runs cooler.

10. For 6-volt plating dynamo No. 6 wire gives 2788.  
For 110-volt dynamo No. 18 gives 3150.  
For 220-volt dynamo No. 21 gives 3165.  
For 500-volt dynamo No. 24 gives 3612.

11. For plating dynamo No. 6 wire requires  $12\frac{1}{2}$  pounds.  
For 110-volt dynamo No. 18 requires 16 pounds.  
For 220-volt dynamo No. 21 requires 16 pounds.  
For 500-volt dynamo No. 24 requires  $20\frac{1}{2}$  pounds.



12. One watt per square inch.

13. If thicker than this the heat from the inside layers of wire has difficulty in getting away to the outside surface.

14. .21 of 1 per cent. per degree F.

15. Divide the number of amperes that a coil of one pound will pass by the number of amperes it is desired to have the finished coil pass, and the result is the desired weight.

16. Size of wire required is No. 20. Weight of wire required is 14 pounds per coil.

17. 20.9 pounds of No. 21 wire gives 3,600 a. t. at full pressure of 250 volts and a heat loss of  $\frac{1}{2}$  watt per sq. in.

18. Divide number of ampere turns required by number of amperes that will flow, and the result is the number of turns.

19. It decrease the current by increasing the resistance through the coil and so decreases the power lost in the coil.

20. It increases the resistance and so increases the power lost.

## ANSWERS TO QUESTIONS IN CHAPTER IX.

1. 100,000,000.

2. See text.

3. It is a device by which direct current is obtained from an armature in the wire of which the current is alternating.

4. Because there must be two paths for the passage of the current through a direct current armature, and each path contains only half the amount of wire that is used on the whole armature.

5. 120 volts. 1,500 revolutions.

6. See text.

7. 1,388,889.

8. The best winding will be two parallel of .072 wire, and the resistance of the armature will be .0816 ohms. Dimensions of armature will be found in Fig. 29.

9. If the motor is of the same size it will only be necessary to double the number of turns on the armature.

10. Twice as many turns are required on a gramme ring armature as on a drum armature.

11. In the gramme ring method of winding, adjacent coils are at a small difference of potential, and it is easy to repair a coil if one gets out of order.

12. 223.2 square inches.

13. The number of wires will be doubled, the sectional area will be halved, thus quadrupling the resistance.

## ANSWERS TO QUESTIONS IN CHAPTER X.

1. The electro-motive force produced in an electrical device which tends to reduce the current which the primary electro-motive force would tend to produce.

2. No.

3. Because the counter electro-motive force is very nearly equal to the primary electro-motive force.

4. By an application of formula (14).

5. 925.8 revolutions per minute.

6. 3,174,600.

7. Because as the temperature of the fields rise the resistance rises and the ampere turns decrease, consequently the flux decreases and the speed increases in the same ratio as the flux decreases.

8. The Patton street car was an example of this, in which a gas engine drove a dynamo which on light loads and down grades charged a storage battery, while on heavy loads and up grades it became a motor and absorbed power from the storage battery.

9. The fact that the flux through the armature is constant and the voltage lost due to the resistance of the armature is very small, even at heavy load.

10. Because the voltage lost in a large armature is relatively less for the same heating than in a smaller armature.

11. Because it decreases the counter electro-motive force by decreasing the effective flux through the armature.

12. Volts lost in armature with one ampere equal .08 volts. Volts lost in armature with 30 amperes equal 2.4 volts. The drop in speed in per cent. will be 2.4 divided by 79.92 equals 3 per cent.

13. Because the ampere turns on the field coil of a series motor, and therefore the magnetic flux through the armature, depend upon the load on the armature.

14. Because the flux through the field magnets tends to become constant after the iron becomes saturated.

15. The magnetic flux across an air gap is strictly proportional to the ampere turns expended in the air gap, and if the iron is unsaturated at the highest voltage, practically all the ampere turns will be expended in the air gap and the flux through the armature will be proportional to the voltage, thus making the speed constant.

16. In the same way that the speed of a series motor does, but not in the same degree. There will be an upper limit set to the speed on account of the flux produced by the shunt coil.

17. The torque of an armature is proportional to the product of the current and magnetic flux through it. When the iron is unsaturated the flux through the armature will be doubled by doubling the current, and the double flux, acting on the double current, produces four times the torque.

18. To the current passing through the armature.

19. On a constant potential circuit with no load on the armature the increasing speed produces an increasing counter electro-motive force, which reduces the current through the fields, thus reducing the flux through the armature, which thus tends to further increase the speed. The con-

stant speed is finally reached on account of the mechanical power required to rotate the armature at such a high rate of speed. On a constant current circuit the counter electro-motive force tends to become equal to the primary electro-motive force.

20. In two ways: First, by reducing the ampere turns on the field by means of a centrifugal device; and second, by decreasing the effective flux through the armature by rocking the brushes.

## ANSWERS TO QUESTIONS ON CHAPTER XI.

1. Molecular friction.
2. An alternating current would set up changes in the direction of the magnetic flux, and therefore produce hysteresis, while a direct current would not.
3. Because at the same number of revolutions per minute there are twice as many reversals of magnetism in a four-pole motor armature as in a two-pole.
4. The direction of the magnetism is reversed in the iron core of an armature in passing from a south pole to a north pole.
5. Currents other than the main current set up in an armature due to its rotation, which produce wasteful heat.
6. In the same direction that the currents flow in the wires.
7. To prevent eddy currents.
8. To prevent eddy currents in the copper, which would be formed in the large solid conductor.
9. With a very short air gap there will be tufts of lines flowing from the pole pieces to the armature teeth, and therefore the flux of lines from a small given area of surface on the pole piece changes and so produces currents in accordance with Lenz law.
10. The permeability of steel pole pieces is so much greater than that of cast iron that it permits of this tufting to a much greater extent than cast iron.

11. The armature in Fig. 35 is four-pole and there will be two currents in one direction across it and two currents in the opposite direction. The voltage of one of these currents will be .48, or practically  $\frac{1}{2}$  of a volt; the resistance will be 1.6 of an ohm in the whole path of one of these currents. The watts lost will be .143 of a watt. The power lost will be  $\frac{5}{8}$  of a watt.

12. No.

13. To more perfectly insulate the armature discs from each other than is possible by means of the oxide on the surface of each disc.

14. The heating of the armature chars this paper insulation, and so loosens the armature discs on the shaft between the end plates.

15. As the square of the speed.

## ANSWERS TO QUESTIONS ON CHAPTER XII.

1. The action of the armature as a magnet due to the current which it generates passing around it.

2. On the amount of current delivered by the armature.

3. In a general way it is magnetized at right angles to the fields.

4. Because this pole piece is of opposite polarity to the pole produced in the armature, while the pole piece which the armature is approaching is of the same polarity as the armature, and there is consequently attraction between the first two and repulsion between the last two.

5. The movement of the brushes gives a component of the armature reaction, which tends to increase or decrease the flux produced by the field coils.

6. In order to stop the sparking the brushes must be rocked in such a direction that the armature reaction has a component which opposes the flux produced by the field coils.

7. They would have to be rocked backward, in a direction opposite to that of rotation, and this would produce severe sparking.

8. In constant current dynamos.

9. By rocking the brushes into various positions which controls the effect of the armature reaction in reducing the flux produced by the field coils, and so controls the voltage produced by the dynamo.



10. By reducing the current through the field coils and so weakening the flux, and consequently the voltage produced. This effect is greatly assisted by the effect of armature reaction and by rocking the brushes.

11. They should be set forward in the direction of rotation, which will usually cause severe sparking.

12. Not more than half the ampere turns in the field coil.

13. A gramme ring armature has twice as many turns as a drum armature, in order to produce the same voltage; therefore this form of armature has a great armature reaction with a given current. Armature reaction is necessary in a constant current machine and should be avoided as much as possible in a constant potential machine. Another reason is that it is easier to insulate successfully a gramme ring armature for the high voltages produced in arc machines than a drum armature.

14. The field is made multi-polar.

15. A four-pole machine would have half the ampere turns on each armature pole and the same number of ampere turns in the air gap on each field pole if the same voltage is to be produced. Therefore the armature reaction will be decreased by half.

## ANSWERS TO QUESTIONS ON CHAPTER XIII.

1. It is reversed.
2. Half the total armature current.
3. Chiefly on the field in which the coil is moving at the time, also on the resistance of leads and brushes.
4. To reduce the current in the short circuited coil to 0.
5. If the short circuited coil carries one-half the total armature current at the moment it ceases to be short circuited, perfect commutation will have been effected.
6. To retard the change of current in the short circuited coil and so to produce sparking.
7. None.
8. Because in a dynamo rocking the brushes forward brings the short circuited coil into a magnetic field, that tends to reverse the direction of current in the short circuited coil from what it was before it was short circuited, while in a motor the reverse is true.
9. No.
10. The production of over one-half the total armature current in the short circuited coil in the same direction that current flows in it after the coil leaves the brush.
11. Rock them a long distance forward.
12. The resistance between brush and commutator.

13. It tends to cause the current to pass from the brush to the commutator evenly all over the brush.

14. Over-commutation is only possible where current is flowing in opposition to the main current in one of the leads.

15. On account of their resistance they tend to make the current enter the commutator evenly over the whole surface of the brush.

16. The greater resistance of the carbon brush produces more heat than the copper brush with a given current.

17. It will stop it entirely.

18. Because its resistance is very much higher.

19. It allows time for the voltage to overcome the self-induction of the coil to be commutated.

20. See text.

21. The arc that is formed between bar and brush melts the edge of the copper bar and it appears as a fine flake of copper dust.

22. It must be very low in order to avoid sparking.

23. It shows that the commutation produced on account of the resistance of the brush is of much more importance in perfect commutation than that produced by the magnetic field.

## ANSWERS TO QUESTIONS IN CHAPTER XIV

1. As a conductor in which E. M. F. is produced; second, as a conductor to carry the current to magnetize the fields.
2. A circle surrounds the greatest area with the least length.
3. It reduces the leakage surfaces.
4. It must all flow in the same direction.
5. Because the N. and S. poles are 90 degrees apart.
6. 36 degrees for 36 degrees is 1-10 of the circumference of a circle, and current must flow in opposite directions in zones 36 degrees wide.
7. In order that the mechanical force shall be exerted in all the wires under the two poles in the same directions as explained in chapter IV.
8. 500 volts as a maximum.
9. About 15.6 volts for both third and fourth and eleventh and twelfth.
10. The full voltage on the armature.
11. One in which there is small difference of potential between coils in the same layer and the full difference of potential or voltage between the two layers.
12. One in which each coil occupies the full depth of the winding on the armature and in which there is a maximum difference of potential between coils of the same layer.

13. By carrying the leads or connections from the armature winding spirally around the armature the desired distance.

14. A wave winding is one in which it is possible to use two brushes on an armature for a four-pole machine without cross connecting the commutator. Under the same circumstances a lap winding would require four brushes.

15. Better magnetic balance in a unsymmetrical field and half the number of turns of wire.

16. Because the magnet poles are 60 degrees apart.

17. The positive brushes would be at 0 degree, 120 degrees and 240 degrees. The negative brushes would be at 60 degrees, 180 degrees and 300 degrees. With a wave-wound armature it is necessary to use only one positive and one negative brush, and these may be selected on opposite sides of the commutator if desired.

18. 216.

19. 108.

20. The wave-wound armature will have four times the resistance.

21. By cross connecting the commutator or connecting opposite bars on the commutator to each other.

22. The wave-wound armature will operate just as if the armature was central. In the lap-wound armature one of the circuits will produce a higher voltage than others, and therefore tends to produce local currents in the armature.

23. It cannot be connected symmetrically to the commutator.

2 . Diagram, Fig. 88.

25. A dynamo which has both series and shunt coils.

26. To produce a machine which will produce a constant voltage on a variable load.

27. The speed drops with increased load; volts lost in the armature drop, the armature reaction decreases the total flux. These three causes decrease the voltage on the fields and therefore the ampere turns on the magnet.

28. 4,200.

29. A compound wound motor has the characteristics of both the series and shunt motors, the series winding making the speed variations greater than with the plain shunt motor.

30. A compound wound motor will not spark on overload and has a greater torque with the same current than a plain shunt wound motor.

31. At 500 volts the magnetic circuit is nearly saturated, and the increase in the ampere turns due to the series coil does not produce a proportional increase in the flux, while at 250 volts it does.

## ANSWERS TO QUESTIONS ON CHAPTER XV.

1. It causes self-excitation.
2. No.
3. Reversing the connections causes the current due to the residual magnetism to flow around the magnets in such a way as to decrease the residual magnetism instead of increase it.
4. From two to five per cent.
5. The saturation of the iron in the magnets.
6. It would rise to an infinite voltage or until some part broke down.
7. Connections between field and armature should be reversed.
8. By bringing the machine up to speed, measuring the voltage due to residual magnetism with a milli volt meter, then making the connection with the field magnet coil and noting whether the voltage rises or falls when this connection is made.
9. As the load begins to come on the voltage will fall very rapidly.
10. Moving the rheostat arm increases or decreases the resistance in the shunt circuit. This changes the current through the shunt coil, which changes the ampere turns on the magnetizing circuit, and therefore the flux and voltage.
11. The arc obtained by suddenly opening a field circuit.

12. 6,750 volts.
13. 36,000.
14. So that the circuit can never be entirely opened.
15. In order that the possibility of a field discharge may be avoided.
16. The ends of the shunt coil are always connected by the resistance in the starting box and the armature.
17. To insert the resistance of the starting box in series with the armature to avoid sudden overload on the armature when the current returns.
18. With a series and shunt winding opposing each other. See text.



## ANSWERS TO QUESTIONS ON CHAPTER XVI.

1. A break in the armature winding which prevents the passage of the armature current.
2. By severe arcing on the commutator.
3. By connecting together the two commutator bars between which the arc occurs.
4. A connection in the armature or commutator which allows a local current to flow.
5. 2,750 amperes.
6. By heating the short circuited coil.
7. It will completely short circuit the armature, and it will refuse to generate as a dynamo.
8. It will run only a half revolution at a time.
9. Imperfect contact between brushes and commutator.
10. Continual contact and a constant pressure between brushes and commutator.
11. See text.
12. The inertia does not allow the brush to move quickly.
13. Heating and cutting the commutator and sparking.
14. Forward in the direction of rotation.
15. Backward in the direction opposite to that of rotation.
16. See text.
17. An unintentional connection between the armature or field winding and the frame.

18. To short circuit part of the armature or field winding.
19. Yes. If it has only a single ground.
20. To remove the intentional ground.
21. By making tests and finding the point of lowest voltage between the armature winding and the core.
22. If the short circuit is between the series coil and that part of the shunt coil connected to the pole of the machine opposite to that to which the series coil is connected, the machine will be completely short circuited.
23. By refusing to build up if it is a dynamo and by refusing to carry a heavy load with an ordinary current if a motor.
24. By short circuiting one coil after another and making a test each time until the field circuit as a whole is closed.
25. To decrease its magnetizing power and cause it to run cooler.
26. Because in the field coil the current is caused to flow by an external voltage, and if the resistance decreases the voltage decreases; while in the armature each turn produces a constant electro-motive force which is independent of the resistance of the circuit.
27. By causing four times the amount of heat to be generated in the field coil that remains in good condition.
28. It causes a machine to act as if the field circuit was open, if there are only two field coils.
29. By winding more wire on each field coil.
30. The minute elongation of each tooth as it suddenly enters the magnetic field,

## ANSWERS TO QUESTIONS ON CHAPTER XVII.

1. By the heat produced by the passage of a current through the high resistance of a small carbon filament.

2. Primarily to keep the filament from being burned up.

3. Because it is absolutely necessary to preserve the vacuum, and platinum is the only metal that contracts and expands at the same rate as glass.

4. It must be constant.

5. From  $2\frac{1}{2}$  to  $4\frac{1}{2}$ .

6. If one is paying for both lamps and electricity and wants light, it will pay to remove the dim lamps and replace them with new ones at such a time that the cost of current and lamps to produce a given amount of light shall be a minimum.

7. About 7000 degrees Fahrenheit.

8. Between 1-4 and 1-5.

9. Because the light is more diffused.

10. The oxygen of the air is excluded from the hot carbons.

11. See text.

## ANSWERS TO QUESTIONS ON CHAPTER XVIII.

1. A current proportional to the voltage.
2. Ohm's law.
3. Down through the plane of the paper.
4. The eddy currents generated in the copper coil on which the wire carrying the current is wound.
5. Magnetic field uniform.
6. The mechanical force acting on the wires carrying current and the reaction of the hair springs.
7. On the constancy of the permanent magnet.
8. A difference in the size of wire on the movable coil which in the ammeter is adapted to receive much larger currents at a correspondingly lower voltage.
9. See text.
10. See text.
11. The error introduced by the hysteresis of the soft iron.
12. Write answer and compare with text.
13. Write answer and compare with text.

## ANSWERS TO QUESTIONS ON CHAPTER XIX.

1. A current which is constantly reversing its direction.
2. From 12 to 16,000 per minute.
3. The time required for two successive alternations.
4. 36 2-3.
5. By connecting a circuit to two rings attached to opposite points on a direct current bi-polar commutator.
6. The form of alternating current wave produced by a coil revolving in a uniform field.
7. A single alternating current.
8. Two alternating currents produced or used by the same machine in such relation to each other that when one is zero the other is maximum.
9. To four points 90 degrees apart.
10. Three alternating currents having a certain relation to each other set forth in answer to question 11.
11. By taking current from three rings attached to three points on a two-pole direct current dynamo 120 degrees apart.
12. Because two-phase circuits are attached to points 90 degrees apart on a direct current bi-polar commutator, and to produce a three-phase to points 120 degrees apart.
13. Fig. 86.
14. The volts and amperes can be transformed by static apparatus.

15. A device of iron and copper by which electric energy is transferred from one circuit to another without metallic contact.

16. To receive a small current at a high voltage and produce a large current at a correspondingly lower voltage, or vice versa.

17. On account of the magnetic flux which is common to both the primary and the secondary coils.

18. The self-induction of the coil produces a counter electro-motive force, which is very nearly equal to the primary electro-motive force.

19. The ampere turns of the secondary coil oppose those of the primary, but the primary coil must always have enough ampere turns to force sufficient magnetic flux around the circuit to keep up its counter electro-motive force. When the resistance in the secondary circuit decreases, the current, by Ohm's law, increases, and the current in the primary must correspondingly increase.

20. They are practically equal.

21. A transformer of special design which has a small number of turns on the primary and a very great number on the secondary.

22. On account of the flexibility of transformation and simplicity and reliability of generators and motors.

TABLE XI.  
TENSILE STRENGTH OF COPPER WIRE.

Numbers, B. & S. G.	Breaking weight Pounds		Numbers, B. & S. G.	Breaking weight Pounds	
	Hard- drawn	Annealed		Hard- drawn	Annealed
0000	8 310	5 650	9	617	349
000	6 580	4 480	10	489	277
00	5 226	3 553	11	388	219
0	4 558	2 818	12	307	174
1	3 746	2 234	13	244	138
2	3 127	1 772	14	193	109
3	2 480	1 405	15	153	87
4	1 967	1 114	16	133	69
5	1 559	883	17	97	55
6	1 237	700	18	77	43
7	980	555	19	61	34
8	778	440	20	48	27

The strength of soft copper wire varies from 32 000 to 36 000 pounds per square inch, and of hard copper wire from 45 000 to 68 000 pounds per square inch, according to the degree of hardness.

The above table is calculated for 34 000 pounds for soft wire and 60 000 pounds for hard wire, except for some of the larger sizes, where the breaking weight per square inch is taken at 50 000 pounds for 0 000,000 and 00,55 000 for 0, and 57 000 pounds for 1.

TABLE XII.  
CIRCUMFERENCES OF CIRCLES.  
ADVANCING BY TENTHS.

Diam.	.0	.1	.2	.3	.4	.5	.6	.7	.8	.9	Diam.
0	.00	.31	.62	.94	1.25	1.57	1.88	2.19	2.51	2.82	0
1	3.14	3.45	3.77	4.08	4.39	4.71	5.02	5.34	5.65	5.61	1
2	6.28	6.59	6.91	7.22	7.53	7.85	8.16	8.48	8.79	9.11	2
3	9.42	9.74	10.05	10.36	10.68	10.99	11.30	11.62	11.93	12.25	3
4	12.56	12.88	13.19	13.50	13.82	14.13	14.45	14.76	15.08	15.39	4
5	15.70	16.02	16.33	16.65	16.96	17.27	17.59	17.90	18.22	18.53	5
6	18.84	19.16	19.47	19.79	20.10	20.42	20.73	21.04	21.36	21.67	6
7	21.99	22.30	22.61	22.93	23.24	23.56	23.87	24.19	24.50	24.81	7
8	25.13	25.44	25.76	26.07	26.38	26.70	27.01	27.33	27.64	27.96	8
9	28.27	28.58	28.90	29.21	29.53	29.84	30.15	30.47	30.78	31.10	9
10	31.41	31.73	32.04	32.35	32.67	32.98	33.30	33.61	33.92	34.24	10
11	34.55	34.87	35.18	35.50	35.81	36.12	36.44	36.75	37.07	37.38	11
12	37.69	38.01	38.32	38.64	38.95	39.27	39.58	39.89	40.21	40.52	12
13	40.84	41.15	41.46	41.78	42.09	42.41	42.72	43.03	43.35	43.66	13
14	43.98	44.29	44.61	44.92	45.23	45.55	45.86	46.18	46.49	46.80	14
15	47.12	47.43	47.75	48.06	48.38	48.69	49.00	49.32	49.63	49.95	15
16	50.26	50.57	50.89	51.20	51.52	51.83	52.15	52.46	52.78	53.09	16
17	53.40	53.72	54.03	54.35	54.65	54.97	55.29	55.60	55.92	56.23	17
18	56.54	56.86	57.17	57.49	57.80	58.11	58.43	58.74	59.06	59.37	18
19	59.69	60.00	60.31	60.63	60.94	61.26	61.57	61.88	62.20	62.51	19
20	62.83	63.14	63.46	63.77	64.08	64.40	64.71	65.03	65.34	65.65	20
21	65.97	66.28	66.60	66.91	67.22	67.54	67.85	68.17	68.48	68.80	21
22	69.11	69.42	69.74	70.05	70.37	70.68	71.00	71.31	71.62	71.94	22
23	72.25	72.57	72.88	73.19	73.51	73.82	74.14	74.45	74.76	75.08	23
24	75.39	75.71	76.02	76.34	76.65	76.96	77.28	77.59	77.91	78.22	24
25	78.54	78.85	79.16	79.48	79.79	80.11	80.42	80.73	81.05	81.36	25
26	81.68	81.99	82.30	82.62	82.93	83.25	83.56	83.88	84.19	84.50	26
27	84.82	85.13	85.45	85.76	86.07	86.39	86.70	87.02	87.33	87.65	27
28	87.96	88.27	88.59	88.90	89.22	89.53	89.84	90.16	90.47	90.79	28
29	91.10	91.42	91.73	92.04	92.36	92.67	92.99	93.30	93.61	93.93	29
30	94.24	94.56	94.87	95.19	95.50	95.81	96.13	96.44	96.76	97.07	30
31	97.38	97.70	98.01	98.33	98.64	98.96	99.27	99.58	99.90	100.2	31
32	100.5	100.8	101.1	101.4	101.7	102.1	102.4	102.7	103.0	103.3	32
33	103.6	103.9	104.3	104.6	104.9	105.2	105.5	105.8	106.1	106.5	33
34	106.8	107.1	107.4	107.7	108.0	108.3	108.6	109.0	109.3	109.6	34
35	109.9	110.2	110.5	110.8	111.2	111.5	111.8	112.1	112.4	112.7	35
36	113.0	113.4	113.7	114.0	114.3	114.6	114.9	115.2	115.6	115.9	36
37	116.2	116.5	116.8	117.1	117.4	117.8	118.1	118.4	118.7	119.0	37
38	119.3	119.6	120.0	120.3	120.6	120.9	121.2	121.5	121.8	122.2	38
39	122.5	122.8	123.1	123.4	123.7	124.0	124.4	124.7	125.0	125.3	39
40	125.6	125.9	126.2	126.6	126.9	127.2	127.5	127.8	128.1	128.4	40
41	128.8	129.1	129.4	129.7	130.0	130.3	130.6	131.0	131.3	131.6	41
42	131.9	132.2	132.5	132.8	133.2	133.5	133.8	134.1	134.4	134.7	42
43	135.0	135.4	135.7	136.0	136.3	136.6	136.9	137.2	137.6	137.9	43
44	138.2	138.5	138.8	139.1	139.4	139.8	140.1	140.4	140.7	141.0	44
45	141.3	141.6	142.0	142.3	142.6	142.9	143.2	143.5	143.9	144.2	45
46	144.5	144.8	145.1	145.4	145.7	146.0	146.3	146.7	147.0	147.3	46
47	147.6	147.9	148.3	148.6	148.9	149.2	149.5	149.8	150.1	150.4	47
48	150.7	151.1	151.4	151.7	152.0	152.3	152.6	152.9	153.3	153.6	48
49	153.9	154.2	154.5	154.8	155.1	155.5	155.8	156.1	156.4	156.7	49
50	157.0	157.3	157.7	158.0	158.3	158.6	158.9	159.2	159.5	159.9	50



TABLE XIII.

## AREAS OF CIRCLES ADVANCING BY TENTHS.

Diam.	.0	.1	.2	.3	.4	.5	.6	.7	.8	.9	Diam.
0	.0	.0078	.0314	.0706	.1256	.1963	.2827	.3848	.5026	.6231	0
1	.7854	.9503	1.1309	1.3273	1.5393	1.7671	2.0106	2.2698	2.5446	2.8352	1
2	3.1416	3.4636	3.8013	4.1547	4.5239	4.9087	5.3093	5.7255	6.1575	6.6062	2
3	7.0686	7.5476	8.0424	8.5530	9.0792	9.6211	10.1787	10.7521	11.3411	11.9459	3
4	12.5664	13.2025	13.8544	14.5220	15.2053	15.9043	16.6190	17.3494	18.0951	18.8574	4
5	19.6350	20.4282	21.2372	22.0618	22.9022	23.7583	24.6301	25.5176	26.4208	27.3397	5
6	28.2744	29.2247	30.1907	31.1725	32.1699	33.1831	34.2120	35.2566	36.3168	37.3928	6
7	38.4846	39.5920	40.7151	41.8539	43.0085	44.1787	45.3647	46.5663	47.7837	49.0168	7
8	50.2656	51.5300	52.8102	54.1062	55.4178	56.7451	58.0881	59.4469	60.8213	62.2115	8
9	63.6174	65.0389	66.4762	67.9292	69.3979	70.8823	72.3824	73.8982	75.4298	76.9770	9
10	78.5400	80.1186	81.7130	83.3230	84.9488	86.5903	88.2475	89.9204	91.6090	93.3133	10
11	95.0334	96.7691	98.5205	100.287	102.070	103.869	105.683	107.513	109.359	111.220	11
12	113.097	114.990	116.898	118.823	120.763	122.718	124.690	126.677	128.679	130.698	12
13	132.732	134.782	136.848	138.929	141.026	143.139	145.267	147.411	149.571	151.747	13
14	153.938	156.145	158.368	160.606	162.860	165.130	167.415	169.717	172.034	174.366	14
15	176.715	179.079	181.458	183.854	186.265	188.692	191.134	193.593	196.067	198.556	15
16	201.062	203.583	206.120	208.672	211.241	213.825	216.424	219.040	221.671	224.318	16
17	226.980	229.658	232.352	235.062	237.787	240.528	243.285	246.057	248.846	251.650	17
18	254.469	257.304	260.155	263.022	265.905	268.803	271.716	274.646	277.591	280.552	18
19	283.529	286.521	289.529	292.553	295.593	298.648	301.719	304.805	307.908	311.026	19
20	314.160	317.309	320.474	323.655	326.852	330.064	333.292	336.536	339.795	343.070	20
21	346.361	349.667	352.990	356.328	359.681	363.051	366.436	369.837	373.253	376.685	21
22	380.133	383.597	387.076	390.571	394.082	397.608	401.150	404.708	408.282	411.871	22
23	415.476	419.097	422.733	426.385	430.051	433.737	437.436	441.151	444.881	448.628	23
24	452.390	456.168	459.961	463.770	467.595	471.436	475.292	479.164	483.052	486.955	24
25	490.875	494.809	498.760	502.726	506.708	510.706	514.719	518.748	522.793	526.854	25

AREAS OF CIRCLES.  
ADVANCING BY TENTHS.

Diam.	.0	.1	.2	.3	.4	.5	.6	.7	.8	.9	Diam.
26	530.930	535.022	539.129	543.253	547.392	551.547	555.717	559.903	564.105	568.323	26
27	572.556	576.805	581.070	585.350	589.646	593.958	598.286	602.629	606.988	611.363	27
28	615.753	620.159	624.581	629.019	633.472	637.941	642.425	646.926	651.442	655.973	28
29	660.521	665.084	669.663	674.258	678.868	683.494	688.136	692.793	697.466	702.155	29
30	706.860	711.580	716.316	721.067	725.835	730.618	735.417	740.231	745.061	749.907	30
31	754.769	759.646	764.539	769.448	774.372	779.313	784.268	789.240	794.227	799.230	31
32	804.249	809.284	814.334	819.399	824.481	829.578	834.691	839.820	844.964	850.124	32
33	855.300	860.492	865.699	870.922	876.160	881.415	886.685	891.970	897.272	902.589	33
34	907.922	913.270	918.685	924.011	929.410	934.822	940.249	945.692	951.150	956.625	34
35	962.115	967.620	973.142	978.679	984.231	989.800	995.384	1000.98	1006.60	1012.23	35
36	1017.87	1023.54	1029.21	1034.91	1040.62	1046.34	1052.09	1057.84	1063.62	1069.40	36
37	1075.21	1081.03	1086.86	1092.71	1098.58	1104.46	1110.36	1116.28	1122.21	1128.15	37
38	1134.11	1140.09	1146.08	1152.09	1158.11	1164.15	1170.21	1176.28	1182.37	1188.47	38
39	1194.59	1200.72	1206.87	1213.04	1219.22	1225.42	1231.63	1237.86	1244.10	1250.36	39
40	1256.64	1262.93	1269.23	1275.56	1281.89	1288.25	1294.62	1301.00	1307.40	1313.82	40
41	1320.25	1326.70	1333.16	1339.64	1346.14	1352.65	1359.18	1365.72	1372.28	1378.85	41
42	1385.44	1392.06	1398.67	1405.30	1411.96	1418.62	1425.31	1432.01	1438.72	1445.45	42
43	1452.20	1458.96	1465.74	1472.53	1479.34	1486.17	1493.01	1499.87	1506.74	1513.62	43
44	1520.53	1527.45	1534.38	1541.33	1548.30	1555.28	1562.29	1569.29	1576.32	1583.37	44
45	1590.43	1597.51	1604.60	1611.71	1618.83	1625.97	1633.12	1640.30	1647.48	1654.68	45
46	1661.90	1669.13	1676.37	1683.65	1690.93	1698.23	1705.54	1712.87	1720.21	1727.57	46
47	1734.94	1742.33	1749.74	1757.16	1764.60	1772.05	1779.52	1787.01	1794.51	1802.02	47
48	1809.56	1817.10	1824.67	1832.25	1839.84	1847.45	1855.08	1862.72	1870.38	1878.05	48
49	1885.74	1893.45	1901.17	1908.90	1916.65	1924.42	1932.20	1940.00	1947.82	1955.65	49
50	1963.50	1971.36	1979.23	1987.13	1995.04	2002.96	2010.90	2018.86	2026.83	2034.82	50

TABLE XIV.

## AREAS OF SMALL CIRCLES.

ADVANCING BY HUNDREDTHS.

Diam.	.00	.01	.02	.03	.04	.05	.06	.07	.08	.09
.0	.0	.000078	.00031	.0007	.00125	.00196	.00283	.00385	.00503	.00636
.1	.0078	.0095	.00113	.0133	.0154	.0177	.0201	.0227	.0255	.0283
.2	.0314	.03464	.038	.0415	.0452	.0491	.0531	.0572	.0616	.0666
.3	.0706	.0755	.0804	.0855	.0908	.0962	.1018	.1075	.1134	.1195
.4	.1256	.132	.1385	.1442	.1520	.1590	.1662	.1735	.181	.1886
.5	.1963	.2043	.2124	.2206	.2290	.2376	.2463	.2552	.2642	.2734
.6	.2827	.2922	.3014	.3117	.3217	.3318	.3421	.3526	.3632	.3739
.7	.3848	.3959	.4071	.4185	.4301	.4418	.4536	.4657	.4778	.4902
.8	.5026	.5153	.5281	.5411	.5542	.5674	.5809	.5945	.6082	.6221
.9	.6362	.6504	.6648	.6793	.694	.7088	.7238	.739	.7543	.7698

TABLE XV.

## PRICE LIST OF COPPER MAGNET WIRE.

Size, B. & S. Gauge	Cotton		Silk	
	Single	Double	Single	Double
16	.....	.....	\$ 1 12	\$ 1 53
17	.....	.....	1 12	1 53
18	.....	.....	1 15	1 57
19	.....	.....	1 15	1 57
20	\$ 0 60	\$ 0 74	1 18	1 61
21	70	88	1 20	1 63
22	76	95	1 30	1 76
23	83	1 05	1 42	1 93
24	90	1 14	1 56	2 13
25	1 00	1 27	1 81	2 48
26	1 10	1 38	2 10	2 88
27	1 25	1 57	2 25	3 07
28	1 35	1 69	2 38	3 27
29	1 50	1 89	2 75	3 76
30	1 65	2 07	2 95	4 02
31	1 80	2 23	3 25	4 40
32	1 95	2 28	3 45	4 53
33	2 40	2 85	3 90	5 10
34	2 85	3 42	4 10	5 30
35	3 25	3 88	5 85	7 78
36	4 37	4 93	7 00	8 88
37	6 75	7 25	11 00	13 63
38	9 00	9 50	13 00	14 50
39	11 00	12 00	15 00	18 00
40	13 00	15 00	20 00	23 00

TABLE XVI.

## SPECIFIC GRAVITIES OF METALS.

Names of metals	Specific gravity	Weights per cubic foot	Specific heat	Melting point in degrees Fahrenheit
Aluminum, cast.....	2.5	156.06	.214 3	.....
“ hammered...	2.67	166.67	.....	.....
Antimony .....	6.702	418.37	.050 8	810.
Arsenic.....	5.763	359.76	.081 4	365.
Barium .....	4.	249.7	.....	.....
Bismuth .....	9.822	613.14	.030 8	497.
Cadmium .....	8.604	537.1	.056 7	500.
Calcium.....	1.566	97.76	.....	.....
Chromium .....	7.3	455.7	.....	.....
Cobalt .....	8.6	536.86	.107	.....
Copper.....	8.895	555.27	.095 1	1 996.
“ rolled .....	8.878	554.21	.....	.....
“ cast .....	8.788	548.59	.....	.....
“ drawn.....	8.946	558.47	.....	.....
“ hammered.....	8.958	559.25	.....	.....
“ pressed.....	8.931	557.52	.....	.....
“ electrolytic.....	8.914	556.46	.....	.....
Gold .....	19.258	1 202.18	.032 4	2 016.
Iron, bar.....	7.483	467.18	.13	2 786.
“ wrought .....	7.79	486.29	.113	3 286.
Steel .....	7.85	490.03	.116	3 286.
Lead .....	11.445	714.45	.031 4	612.
Magnesium .....	2.24	139.83	.249 9	.....
Manganese.....	6.9	430.73	.114	3 000.
Mercury.....	13.568	846.98	.031 9	38.
Nickel.....	7.832	488.91	.109 1	280 0.
Platinum .....	20.3	1 267.22	.032 4	328 6.
Potassium .....	.855	54.	.169 6	136.
Silver .....	10.522	656.84	.057	1 873.
Sodium .....	.972	60.68	.293 4	194.
Strontium .....	2.504	156.31	.....	.....
Tin.....	7.291	455.14	.056 2	442.
Zinc .....	6.861	428.29	.095 5	773.

# WIRE GAUGES IN MILLS.

## TABLE XVII.

Numbers	Roebing	Brown & Sharpe	Birmingham or Stubs	New British standard
000 000	460.	.....	.....	464.
00 000	430.	.....	.....	432.
0 000	393.	460	454.	400.
000	362.	409.6	425.	372.
00	331.	364.8	380.	348.
0	307.	324.9	340.	324.
1	283.	289.3	300.	300.
2	263.	257.6	284.	276.
3	244.	229.4	259.	252.
4	225.	204.3	238.	232.
5	207.	181.9	220.	212.
6	192.	162.	203.	192.
7	177.	144.3	180.	176.
8	162.	128.5	165.	160.
9	148.	114.4	148.	144.
10	135.	101.9	134.	128.
11	120.	90.74	120.	116.
12	105.	80.81	109.	104.
13	92.	71.96	95.	92.
14	80.	64.08	83.	80.
15	72.	57.07	72.	72.
16	63.	50.82	65.	64.
17	54.	45.26	58.	56.
18	47.	40.3	49.	48.
19	41.	35.89	42.	40.
20	35.	31.96	35.	36.
21	32.	28.46	32.	32.
22	28.	25.35	28.	28.
23	25.	22.57	25.	24.
24	23.	20.1	22.	22.
25	20.	17.9	20.	20.
26	18.	15.94	18.	18.
27	17.	14.2	16.	16.4
28	16.	12.64	14.	14.8
29	15.	11.26	13.	13.6
30	14.	10.03	12.	12.4
31	13.5	8.93	10.	11.6
32	13.	7.95	9.	10.8
33	11.	7.08	8.	10.
34	10.	6.3	7.	9.2
35	9.5	5.62	5.	8.4
36	9.	5.	4.	7.6

TABLE XVII.

## DECIMAL EQUIVALENTS OF PARTS OF AN INCH.

8ths	16ths	32ds	64ths
$\frac{1}{8}$ equals .125	$\frac{1}{16}$ equals .0625	$\frac{1}{32}$ equals .03125	$\frac{1}{64}$ equals .015625
$\frac{1}{4}$ " .250	$\frac{3}{16}$ " .1875	$\frac{3}{32}$ " .09375	$\frac{3}{64}$ " .046875
$\frac{3}{8}$ " .375	$\frac{5}{16}$ " .3125	$\frac{5}{32}$ " .15625	$\frac{5}{64}$ " .078125
$\frac{1}{2}$ " .500	$\frac{7}{16}$ " .4375	$\frac{7}{32}$ " .21875	$\frac{7}{64}$ " .109375
$\frac{5}{8}$ " .625	$\frac{9}{16}$ " .5625	$\frac{9}{32}$ " .28125	$\frac{9}{64}$ " .140625
$\frac{3}{4}$ " .750	$\frac{11}{16}$ " .6875	$\frac{11}{32}$ " .34375	$\frac{11}{64}$ " .171875
$\frac{7}{8}$ " .875	$\frac{13}{16}$ " .8125	$\frac{13}{32}$ " .40625	$\frac{13}{64}$ " .203125
.....	$\frac{15}{16}$ " .9375	$\frac{15}{32}$ " .46875	$\frac{15}{64}$ " .234375
.....	.....	$\frac{17}{32}$ " .53125	$\frac{17}{64}$ " .265625
.....	.....	$\frac{19}{32}$ " .59375	$\frac{19}{64}$ " .296875
.....	.....	$\frac{21}{32}$ " .65625	$\frac{21}{64}$ " .328125
.....	.....	$\frac{23}{32}$ " .71875	$\frac{23}{64}$ " .359375
.....	.....	$\frac{25}{32}$ " .78125	$\frac{25}{64}$ " .390625
.....	.....	$\frac{27}{32}$ " .84375	$\frac{27}{64}$ " .421875
.....	.....	$\frac{29}{32}$ " .90625	$\frac{29}{64}$ " .453125
.....	.....	$\frac{31}{32}$ " .96875	$\frac{31}{64}$ " .484375
.....	.....	.....	$\frac{33}{64}$ " .515625
.....	.....	.....	$\frac{35}{64}$ " .546875
.....	.....	.....	$\frac{37}{64}$ " .578125
.....	.....	.....	$\frac{39}{64}$ " .609375
.....	.....	.....	$\frac{41}{64}$ " .640625
.....	.....	.....	$\frac{43}{64}$ " .671875
.....	.....	.....	$\frac{45}{64}$ " .703125
.....	.....	.....	$\frac{47}{64}$ " .734375
.....	.....	.....	$\frac{49}{64}$ " .765625
.....	.....	.....	$\frac{51}{64}$ " .796875
.....	.....	.....	$\frac{53}{64}$ " .828125
.....	.....	.....	$\frac{55}{64}$ " .859375
.....	.....	.....	$\frac{57}{64}$ " .890625
.....	.....	.....	$\frac{59}{64}$ " .921875
.....	.....	.....	$\frac{61}{64}$ " .953125
.....	.....	.....	$\frac{63}{64}$ " .984375

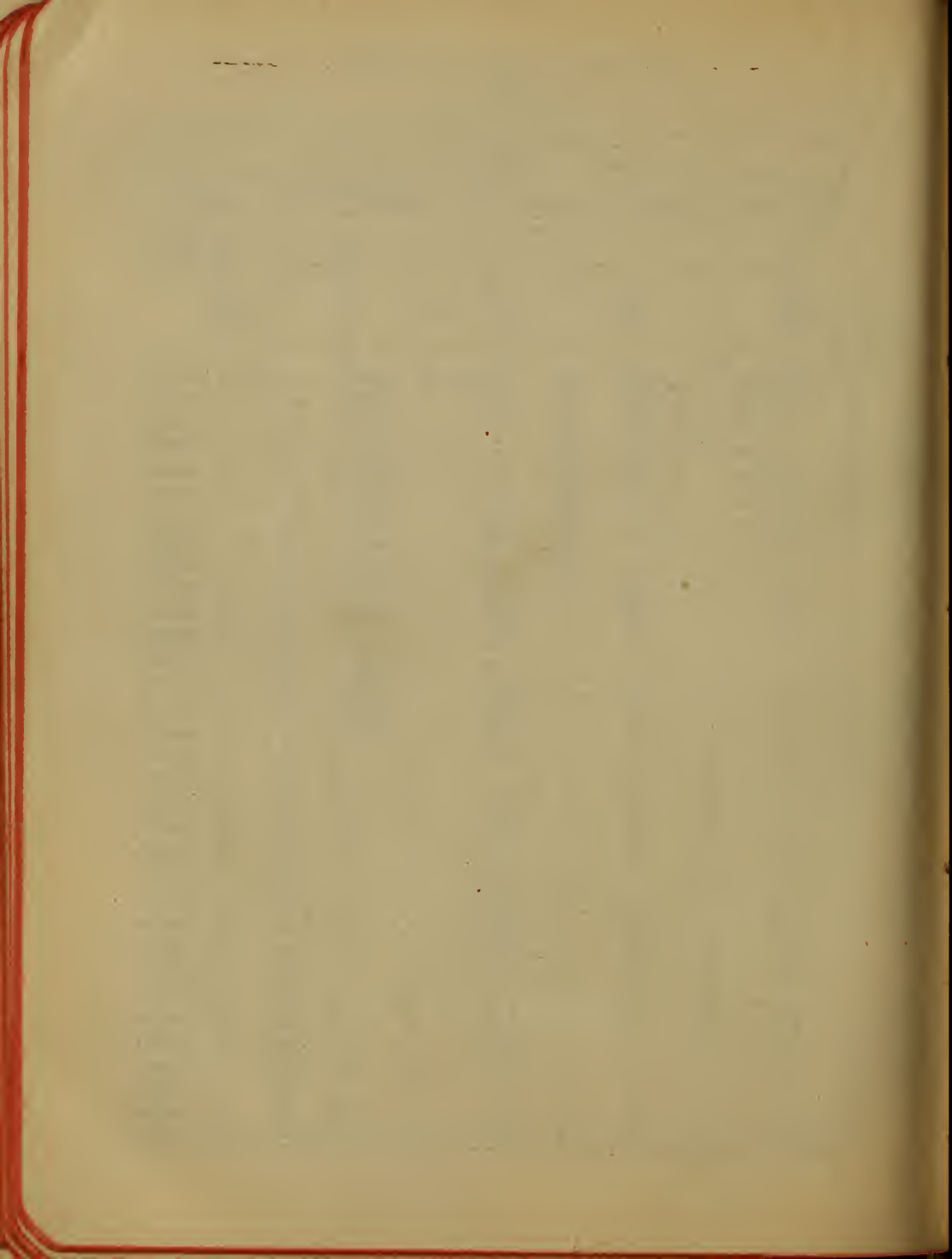



## ELECTRICAL WORDS, TERMS AND PHRASES DEFINED

### A

A. C.—Abbreviation for alternating current.

ACCELERATION—The rate of change of speed or velocity.

ACCUMULATOR, A SECONDARY OR STORAGE CELL—

Two inert plates partially surrounded by a fluid incapable of acting chemically on either of them until after the passage of an electric current, when they become capable of furnishing an independent electric current.

AFFINITY, CHEMICAL—Atomic attraction.

The force which causes atoms to unite and form chemical molecules.

ALARM, BURGLAR—A device, generally electric, for automatically announcing the opening of a door, window, closet, drawer, or safe, or the passage of a person through a hallway, or on a stairway.

ALARM, ELECTRIC—An automatic device by which attention is called to the occurrence of certain events.

ALLOY—A combination, or mixture, of two or more metallic substances.

ALLOY, GERMAN SILVER—An alloy employed for the wires of resistance coils, consisting of 50 parts of copper, 25 of zinc, and 25 of nickel.

**ALPHABET, TELEGRAPHIC: MORSE'S**—Various groupings of dots and dashes, which represent the letters of the alphabet or other signs.

**ALTERNATIONS**—Changes in the direction of a current in a circuit.

A current that changes its direction 300 times per second is said to possess 300 alternations per second.

**ALTERNATIONS, COMPLETE**—A change in the direction of a current in a circuit from its former direction and back again to that direction. A complete to-and-fro change.

Complete alternations are sometimes indicated by the symbol. 

**ALTERNATOR**—A name commonly given to an alternate current dynamo.

**AMALGAM**—A combination or mixture of a metal with mercury.

**AMBER**—A resinous substance, generally of a transparent, yellow color.

**AMMETER**—A form of galvanometer in which the value of the current is measured directly in amperes.

**AMMETER, MAGNETIC-VANE**—An ammeter in which the strength of a magnetic field produced by the current that is to be measured is determined by the repulsion exerted between a fixed and movable iron vane, placed in said field and magnetized thereby.

**AMMETER, PERMANENT-MAGNET**—A form of ammeter in which a magnetic needle is moved against the field of a permanent magnet by the field of the current it is measuring.

**AMPERAGE**—The number of amperes passing in a given circuit.

**AMPERE**--The practical unit of electric current.

Such a current as would pass with an electromotive force of one volt through a circuit whose resistance is equal to one ohm.

A current of such strength as would deposit .005034 grain of copper per second.

**AMPERE-TURN**--(See Turn, Ampere).

**ANION**--The electro-negative radical of a molecule.

An anion is that group of atoms of an electrically decomposed of electrolyzed molecule which appears at the anode.

**ANNUNCIATOR, ELECTRO-MAGNETIC**--An electric device for automatically indicating the points or places at which one or more electric contacts have been closed.

**ANNUNCIATOR, HOTEL**--An annunciator connected with the different rooms of a hotel.

**ANODE**--The conductor or plate of a decomposition cell connected with the positive terminal of a battery, or other electric source.

That terminal of an electric source out of which the current flows into the liquid of a decomposition cell.

**ARC**--A voltaic arc.

**ARC**--To form a voltaic arc.

**ARC, ALTERNATING**--A voltaic arc formed by means of an alternating current.

**ARC, HISSING OF**--A hissing sound attending the formation of voltaic arcs when the carbons are too near together.

ARC, VOLTAIC—The source of light of the electric arc lamp.

ARM BRIDGE—One of the sections in a Wheatstone bridge for necessary resistance.

ARM-CROSS—A transverse piece attached to a pole for the support of wires.

ARM, ROCKER—An arm on which the brushes of a dynamo or motor are mounted for the purpose of shifting their position on the commutator.

ARMATURE—A mass of iron or other magnetizable material placed on or near the pole or poles of a magnet.

ARMATURE, BI-POLAR—An armature of a dynamo-electric machine the polarity of which is reversed twice in every revolution through the field of the machine.

ARMATURE, DRUM—An armature of a dynamo-electric machine, in which the armature coils are wound longitudinally over the surface of a cylinder or drum.

ARMATURE, DYNAMO-ELECTRIC MACHINE—That part of a dynamo-electric machine in which the differences of potential which cause the useful currents are generated.

ARMATURE, POLARIZED—An armature which possesses a polarity independent of that imparted by the magnet pole near which it is placed.

ARMATURE, RING—A dynamo-electric machine armature, the coils of which are wound on a ring-shaped core.

ARMATURE, SPHERICAL—A dynamo-electric machine armature, the coils of which are wound on a spherical iron core.

**ARRESTER, LIGHTNING**—A device by means of which the apparatus placed in any electric circuit is protected from the destructive effects of a flash or bolt of lightning.

**ASTATIC**—Possessing no directive power.

Usually applied to a magnetic or electro-magnetic device which is free from any tendency to take a definite position on account of the earth's magnetism.

**ATMOSPHERE, AN**—A unit of gas or fluid pressure equal to about 15 pounds to the square inch.

**ATTRACTION, MAGNETIC**—The mutual attraction exerted between unlike magnet poles.

**AURORA BOREALIS**—The Northern Light. Luminous sheets, columns, arches, or pillars of pale, flashing light, generally of a red color, seen in the northern heavens.

**AUTOMATIC CONTACT BREAKER**—(See Contact Breaker, Automatic).

**AUTOMATIC CUT-OUT**—(See Cut-Out, Automatic).

## B

**B**—A contraction used in mathematical writings for the internal magnetization, or the magnetic induction, or the number of lines of force per square inch or per square centimetre in the magnetized material.

**B. A. OHM**—(See Ohm, P. A.)

**B. W. G.**—A contraction for Birmingham wire gauge.

**BACK ELECTROMOTIVE FORCE**—(See Force, Electromotive, Back).

**BALANCE, COULOMB'S TORSION**—An apparatus to measure the force of electric or magnetic repulsion between two similarly charged bodies, or between two similar magnet poles, by opposing to such force the torsion of a thin wire.

The two forces balance each other; hence the origin of the name.

**BALANCE, INDUCTION, HUGHES'**—An apparatus for the detection of the presence of a metallic or conducting substance by the aid of induced electric currents.

**BALLS, PITH**—Two balls of pith, suspended by conducting threads of cotton to insulated conductors, employed to show the electrification of the same by their mutual repulsion.

**BARS, BUS**—Omnibus bars. (See Bars, Omnibus).

**BARS, OMNIBUS**—Main conductors common to two or more dynamos in an electrical generating plant.

The terms bus and omnibus bars refer to the fact that the entire or whole current is carried by them.

**BATH, COPPER**—An electrolytic bath containing a readily electrolyzable solution of a copper salt, and a copper plate acting as the anode, and placed in the liquid near the object to be electro-plated, which forms the cathode.

**BATH, ELECTRO-PLATING**—Tanks containing metallic solutions in which articles are placed so as to be electro-plated.

**BATH, NICKEL**—An electrolytic bath containing a readily electrolyzable salt of nickel, a plate of nickel acting as the anode of a battery and placed in the liquid near the object to be coated, which forms the cathode.

**BATTERY, CLOSED-CIRCUIT**—A voltaic battery which may be kept constantly on closed-circuit without serious polarization.

**BATTERY, ELECTRIC**—A general term applied to the combination, as a single source, of a number of separate electric sources.

**BATTERY, GAS**—A battery in which the voltaic elements are gases as distinguished from solids.

**BATTERY, LEYDEN JAR**—The combination of a number of separate Leyden jars so as to act as one single jar.

**BATTERY, LOCAL**—A voltaic battery used at a station on a telegraph line to operate the Morse sounder, or the registering or recording apparatus, at that point only.

**BATTERY, OPEN-CIRCUIT**—A voltaic battery which is normally on open circuit, and which is used continuously only for comparatively small durations of time on closed-circuit.

**BATTERY, PLUNGE**—A number of separate voltaic cells connected so as to form a single cell or electric source, the plates of which are so supported on a horizontal bar as to be capable of being simultaneously placed in, or removed from, the exciting liquid.

**BATTERY, PRIMARY**—The combination of a number of separate primary cells so as to form a single source.

**BATTERY, SECONDARY**—The combination of a number of separate secondary or storage cells, so as to form a single electric source.

**BATTERY SOLUTION**—(See Solution, Battery).

**BATTERY, STORAGE**—A number of separate storage cells connected so as to form a single electric source.

**BATTERY, VOLTAIC**—The combination, as a single source, of a number of separate voltaic cells.

- BELL MAGNETO ELECTRIC—A bell rung by the movement of the armature of an electro magnet.
- BELL, TELEPHONE-CALL—A call bell used to call a correspondent to the telephone.
- BI-POLAR—Having two poles.
- BLASTING, ELECTRIC—The electric ignition of powder or other explosive material in a blast.
- BLOCK, BRANCH—A device employed in electric wiring for taking off a branch from a main circuit.
- BLOCK, FUSE—A block containing a safety fuse or fuses for incandescent light circuits.
- BOARD, HANGER—A form of board provided for the ready placing or removal of an arc lamp from a circuit.
- BOARD, MULTIPLE SWITCH—A board to which the numerous circuits employed in systems of telegraphy, telephony, annunciator or electric light and power circuits are connected.
- BOARD, SWITCH—A board provided with a switch or switches, by means of which electric circuits connected therewith may be opened, closed, or interchanged.
- BOBBIN, ELECTRIC—An insulated coil of wire for an electro-magnet.
- BODY, ELECTRIC RESISTANCE OF—The resistance of the human body measured from hand to hand varies from 3,000 ohms to 15,000 ohms.
- BOLOMETER—An apparatus devised by Langley for measuring small differences of temperature.
- BOMBARDMENT, MOLECULAR—The forcible rectilinear projection from the negative electrode, of the gaseous molecules of the residual atmospheres of exhausted vessels on the passage of electric discharges.



**BORE, ARMATURE**--The space provided between the pole pieces of a dynamo or motor for the rotation of the armature.

**BOX, DISTRICT-CALL**--A box by means of which an electric signal is automatically sent over a telegraphic line and received by an electro-magnetic device at the other end of the line.

**BOX, FIRE-ALARM SIGNAL**--A signal box provided for the purpose of automatically sending an alarm of fire.

**BOX, FUSE**--The box in which the fuse-wire of a safety-fuse is placed.

**BOX, JUNCTION**--A moisture-proof box provided in a system of underground conductors to receive the terminals of the feeders, in which connection is made between the feeders and the mains, and from which the current is distributed to the individual consumer.

**BOX, RESISTANCE**--A box containing a number of separate coils of known resistances employed for determining the value of an unknown resistance, and for other purposes.

**BRAKE, ELECTRO-MAGNETIC**--A brake for car wheels, the braking power for which is either derived entirely from electro-magnetism, or is thrown into action by electro-magnetic devices.

**BRAKE, PRONY**--A mechanical device for measuring the power of a driving shaft.

**BRANCH-BLOCK**--(See Block, Branch).

**BREAKER, CIRCUIT**--Any device for breaking a circuit.

**BRIDGE-ARMS**--(See Arms, Bridge or Balance).

BRIDGE, ELECTRIC—A device for measuring the value of electric resistances.

The electric bridge is also called the Electric Balance.

BRIDGE, MAGNETIC—An apparatus invented by Edison for measuring magnetic resistance, similar in principle to Wheatstone's electric bridge.

BRUSH, DISCHARGE—(See Discharge, Brush).

BRUSH-HOLDERS FOR DYNAMO-ELECTRIC MACHINES—Devices for supporting the collecting brushes of dynamo-electric machines.

BRUSH ROCKER—(See Rocker, Brush).

BRUSHES, ADJUSTMENT OF DYNAMO-ELECTRIC MACHINES—Shifting the brushes into the required position on the commutator cylinder, either non-automatically by hand, or automatically by the current itself.

BRUSHES, CARBON, FOR ELECTRIC MOTORS—Plates of carbon for leading current to electric motors.

These are generally known simply as brushes.

BRUSHES, LEAD OF—The angle through which the brushes of a dynamo-electric machine must be moved forward, or in the direction of rotation, in order to diminish sparking and to get the best output from the dynamo.

BRUSHES OF DYNAMO-ELECTRIC MACHINE—Strips of metal, bundles of wire, slit plates of metal, or plates of carbon, that bear on the commutator cylinder of a dynamo-electric machine, and carry off the current generated.

**BUCKLING**—Irregularities in the shape of the surfaces of the plates of storage cells, following a too rapid discharge.

**BUG**—A term originally employed in quadruplex telegraphy to designate any fault in the operation of the apparatus.

**BUNSEN VOLTAIC CELL**—(See Cell, Voltaic, Bunsen's).

**BURGLAR ALARM ANNUNCIATOR**—(See Annunciator, Burglar Alarm).

**BURNER, AUTOMATIC-ELECTRIC**—An electric device for both turning on the gas and lighting it, and turning it off, by alternately touching different buttons.

**BUS**—A word generally used instead of omnibus.

**BUS-BARS**—(See Bars, Bus).

**BUTTON, CARBON**—A resistance of carbon in the form of a button.

**BUTTON, PUSH**—A device for closing an electric circuit by the movement of a button.

**BUZZER, ELECTRIC**—A call, not as loud as that of a bell, produced by a rapid automatic make-and-break.

## C

**C**—An abbreviation for centigrade.

**C**—A contraction for current.

**C. C.**—A contraction for cubic centimetre.

**C. G. S. UNITS**—A contraction for centimetre-gramme-second units.

C. P.—A contraction for candle power.

CABLE—To send a telegraphic dispatch, by means of a cable.

CABLE, BUNCHED—A cable containing more than a single wire or conductor.

CABLE, CAPACITY OF—The ability of a wire or cable to permit a certain quantity of electricity to be passed into it before acquiring a given difference of potential.

CABLE, ELECTRIC—The combination of an extended length of one or more separately insulated electric conductors, covered externally with a metallic sheathing or armor.

CABLE, SURMARINE—A cable designed for use under water.

CABLEGRAM—A message received by means of a submarine telegraphic cable.

CALIBRATE—To determine the absolute or relative value of the scale divisions, or of the indications of any electrical instrument, such as a galvanometer, electrometer, voltmeter, wattmeter, etc.

CALL-BELL, MAGNETO-ELECTRIC—An electric call-bell operated by currents produced by the motion of a coil of wire before the poles of a permanent magnet.

CALORIE, GREAT—The amount of heat required to raise the temperature of one kilogramme of water from 0 degree C. to 1 degree C.

CALORIE, SMALL—The amount of heat required to raise the temperature of one gramme of water from 0 degree C. to 1 degree C.

**CANDLE**—The unit of photometric intensity. Such a light as would be produced by the consumption of two grains of a standard candle per minute.

**CANDLE, JABLOCHKOFF**—An electric arc light in which the two carbon electrodes are placed parallel to each other and maintained a constant distance apart by means of a sheet of insulating material placed between them.

**CANDLE-POWER**—(See Power, Candle).

**CAOUTCHOUC, OR INDIA-RUBBER**—A resinous substance obtained from the milky juices of certain tropical trees.

**CAPACITY, ELECTROSTATIC**—The quantity of electricity which must be imparted to a given body or conductor as a charge, in order to raise its potential a certain amount.

**CAPACITY, ELECTROSTATIC, UNIT OF**—Such a capacity of a conductor or condenser that an electromotive force of one volt will charge it with a quantity of electricity equal to one coulomb. The farad.

**CAPACITY, SPECIFIC INDUCTIVE**—The ability of a dielectric to permit induction to take place through its mass, as compared with the ability possessed by a mass of air of the same dimensions and thickness, under precisely similar conditions.

**CARBON**—An elementary substance which occurs naturally in three distinct allotropic forms, viz: charcoal, graphite and the diamond.

**CARBON POINTS**—(See Points, Carbon).

CARBON TRANSMITTER FOR TELEPHONES—(See Transmitter, Carbon, for Telephones).

CARBONING LAMPS—(See Lamps, Carboning).

CARBONIZE—To reduce a carbonizable material to carbon.

CARBONS, ARTIFICIAL—Carbons obtained by the carbonization of a mixture of pulverized carbon with different carbonizable liquids.

CARBONS, CORED—A cylindrical carbon electrode for an arc lamp that is molded around a central core of charcoal, or other softer carbon.

CARBONS, FLASHING PROCESS FOR—A process for improving the electrical uniformity of the carbon conductors employed in incandescent lighting, by the deposition of carbon in their pores, and over their surfaces at those places where the electric resistance is relatively great.

CARD, COMPASS—A card used in the mariner's compass, on which are marked the four cardinal points of the compass N, S, E and W, and these again divided into thirty-two points called Rhumbs.

CARDEW VOLTMETER—(See Voltmeter, Cardew).

CATAPHORESIS—A term sometimes employed in place of electric osmose. (See Osmose, Electric).

CATHODE—A term sometimes used instead of Kathode.

CAUTERIZATION, ELECTRIC—Subjecting to cauterization by means of a wire electrically heated.

**CAUTERY, ELECTRIC**—An instrument used for electric cauterization. In electro-therapeutics, the application of variously shaped platinum wires heated to incandescence by the electric current in place of a knife, for removing diseased growths, or for stopping hemorrhages.

**CELL, ELECTROLYTIC**—A cell or vessel containing an electrolyte, in which electrolysis is carried on.

**CELL, POROUS**—A jar of unglazed earthenware, employed in double-fluid voltaic cells, to keep the two liquids separated.

**CELL, SECONDARY**—A term sometimes used instead of storage cell.

**CELL, SECONDARY OR STORAGE, CAPACITY OF**—The product of the current in amperes, by the number of hours the battery is capable of furnishing said current, when fully charged, until exhausted.

**CELL, SELENIUM**—A cell consisting of a mass of selenium fused in between two conducting wires or electrodes of platinized silver or other suitable metal.

**CELL, STORAGE**—A single one of the cells required to form a secondary battery.

**CELL, VOLTAIC**—The combination of two metals, or of a metal and a metalloid, which, when dipped into a liquid or liquids called electrolytes, and connected outside the liquid or liquids by a conductor, will produce a current of electricity.

**CELL, VOLTAIC, BICHROMATE**—A zinc-carbon couple used with an electrolyte known as electropoion, a solution of bichromate of potash and sulphuric acid in water.

CELL, VOLTAIC, BUNSEN'S—A zinc-carbon couple, the elements of which are immersed respectively in electrolytes of dilute sulphuric and strong nitric acids.

CELL, VOLTAIC, CLOSED-CIRCUIT—A voltaic cell that can be left for a considerable time on a closed circuit of comparatively small resistance without serious polarization.

CELL, VOLTAIC, CONTACT THEORY OF—A theory which accounts for the production of difference of potential or electromotive force in the voltaic cell by the contact of the elements of the voltaic couple with one another by means of the electrolyte.

CELL, VOLTAIC, DANIELL'S—A zinc-copper couple, the elements of which are immersed respectively in electrolytes of dilute sulphuric acid, and a saturated solution of copper sulphate.

CELL, VOLTAIC, DOUBLE-FLUID—A voltaic cell in which two separate fluids or electrolytes are employed.

CELL, VOLTAIC, DRY—A voltaic cell in which a moist material is used in place of the ordinary fluid electrolyte.

CELL, VOLTAIC, FULLER'S MERCURY BICHROMATE—A zinc-carbon couple immersed in an electrolyte of electropoion liquid. In which the zinc is in contact with liquid mercury.

CELL, VOLTAIC, GRAVITY—A zinc-copper couple, the elements of which are employed with electrolytes of dilute sulphuric acid or dilute zinc sulphate, and a concentrated solution of copper sulphate respectively.



CELL, VOLTAIC, GROVE—A zinc-platinum couple, the elements of which are used with electrolytes of sulphuric and nitric acids respectively.

CELL, VOLTAIC, LECLANCHE—A zinc-carbon couple, the elements of which are used in a solution of sal-ammoniac and a finely divided layer of black oxide of manganese respectively.

CELL, VOLTAIC, OPEN-CIRCUIT—A voltaic cell that can not be kept on closed circuit, with a comparatively small resistance, for any considerable time without serious polarization.

CELL, VOLTAIC, POLARIZATION OF—The collection of a gas, generally hydrogen, on the surface of the negative element of a voltaic cell.

CELL, VOLTAIC, SILVER CHLORIDE—A zinc and silver couple immersed in electrolytes of sal-ammoniac or common salt, in which chloride of silver is used as the depolarizer.

CELL, VOLTAIC, SMEE—A zinc-silver couple used with an electrolyte of dilute sulphuric acid.

CELL, VOLTAIC, STANDARD, CLARK'S—The form of standard cell designed by Latimer Clark, having an E. M. F. of 1.438 volts at 57 degrees F.

CHARACTERISTIC CURVE—(See Curve, Characteristic).

CHARGE, DISSIPATION OF—The gradual but final loss of any charge by leakage, which occurs even in a well insulated conductor.

**CHARGE, DISTRIBUTION OF**—The variations that exist in the density of an electrical charge at different portions of the surface of all insulated conductors except spheres.

**CHARGE, ELECTRIC**—The quantity of electricity that exists on the surface of an insulated electrified conductor.

**CHARGE, RESIDUAL**—The charge possessed by a charged Leyden jar for a few moments after it has been disruptively discharged by the connection of its opposite coatings.

**CHARGE, RETURN**—A charge induced in neighboring conductors by a discharge of lightning.

**CHARGING ACCUMULATORS**—Sending an electric current into a storage battery for the purpose of rendering it an electric source.

**CHOKING COIL**—(See Coil, Choking).

**CIRCUIT, CLOSED**—A circuit is closed, completed, or made when its conducting continuity is such that the current can pass.

**CIRCUIT, CLOSED-MAGNETIC**—A magnetic circuit which lies wholly in iron or other substance of high magnetic permeability.

**CIRCUIT, CONSTANT-CURRENT**—A circuit in which the current or number of amperes is maintained constant notwithstanding changes occurring in its resistance.

**CIRCUIT, CONSTANT POTENTIAL**—A circuit, the potential or number of volts of which is maintained approximately constant.

- CIRCUIT, EARTH**—A circuit in which the ground or earth forms part of the conducting path.
- CIRCUIT, ELECTRIC**—The path in which electricity circulates or passes from a given point, around or through a conducting path, back again to its starting point.
- CIRCUIT, EXTERNAL**—That part of a circuit which is external to, or outside the electric source.
- CIRCUIT, GROUND**—A circuit in which the ground forms part of the path through which the current passes.
- CIRCUIT, INDUCTIVE**—Any circuit in which induction takes place.
- CIRCUIT, INTERNAL**—That part of a circuit which is included within the electric source.
- CIRCUIT, LOCAL-BATTERY**—The circuit, in a telegraphic system, in which is placed a local battery as distinguished from a main battery.
- CIRCUIT, MAGNETIC**—The path through which the lines of magnetic force pass.
- CIRCUIT, METALLIC**—A circuit in which the ground is not employed as any part of the path of the current, metallic conductors being employed throughout the entire circuit.
- CIRCUIT, MULTIPLE**—A compound circuit, in which a number of separate sources or separate electro-receptive devices, or both, have all their positive poles connected to a single positive lead or conductor, and all their negative poles to a single negative lead or conductor.

**CIRCUIT, MULTIPLE-SERIES**—A compound circuit in which a number of separate sources, or separate electro-receptive devices, or both, are connected in a number of separate groups in series, and these separate groups subsequently connected in multiple.

**CIRCUIT, OPEN**—A broken circuit. A circuit, the conducting continuity of which is broken.

**CIRCUIT, RETURN**—That part of a circuit by which the electric current returns to the source.

**CIRCUIT, SERIES**—A compound circuit in which the separate sources, or the separate electro-receptive devices, or both, are so placed that the current produced in each, or passed through each, passes successively through the entire circuit from the first to the last.

**CIRCUIT, SERIES-MULTIPLE**—A compound circuit, in which a number of separate sources, or separate electro-receptive devices, or both, are connected in a number of separate groups in multiple-arc, and these separate groups subsequently connected in series.

**CIRCUIT, SHORT**—A shunt, or by-path, of comparatively small resistance, around the poles of an electric source, or around any portion of a circuit, by which so much of the current passes through the new path, as virtually to cut out the part of the circuit around which it is placed, and so prevent it from receiving an appreciable current.

**CIRCUIT, SHUNT**—A branch or additional circuit provided at any part of a circuit, through which the current branches or divides, part flowing through the original circuit, and part through the new branch.

- CLARK'S STANDARD VOLTAIC CELL—(See Cell. Voltaic, Standard, Clark's).
- CLEARANCE-SPACE—(See Space, Clearance).
- CLIFATS, ELECTRIC—Suitably shaped pieces of wood, porcelain, hard rubber or other non-conducting material used for fastening and supporting electric conductors to ceilings, walls, etc.
- CLOCK, ELECTRIC—A clock, the works of which are moved, controlled, regulated or wound, either entirely or partially, by the electric current.
- CLUTCH, CARBON, OF ARC LAMP—A clutch or clamp attached to the rod or other support of the carbon of an arc lamp, provided for gripping or holding the carbon.
- CODE, CIPHER—A code in which a number of words or phrases are represented by single words, or by arbitrary words or syllables.
- COIL, CHOKING—A coil of wire so wound on a core of iron as to possess high self-induction.
- COIL, IMPEDANCE—A term sometimes applied to a choking-coil.
- COIL, INDUCTION—An apparatus consisting of two parallel coils of insulated wire employed for the production of currents by mutual induction.
- COIL, INDUCTION, MICROPHONE—An induction coil in which the variations in the circuit of the primary are obtained by means of microphone contacts. (See Microphone).
- COL., KICKING—A term sometimes applied to a Choking-Coil.

- COIL, MAGNET—A coil of insulated wire surrounding the core of an electro-magnet, and through which the magnetizing current is passed.
- COIL, PRIMARY—That coil or conductor of an induction coil or transformer, through which the rapidly interrupted or alternate inducing currents are sent.
- COIL, RESISTANCE—A coil of wire of known electrical resistance employed for measuring resistance.
- COIL, RESISTANCE, STANDARD—A coil the resistance of which is that of the standard ohm or some multiple or sub-multiple thereof.
- COIL, RUIHKORFF—A term sometimes applied to any induction coil, the secondary of which gives currents of higher electromotive force than the primary.
- COIL, SECONDARY—That coil or conductor of an induction coil or transformer, in which alternating currents are induced by the rapidly interrupted or alternating currents in the primary coil.
- COIL, SHUNT—A coil placed in a derived or shunt circuit.
- COIL, SPARK—A coil of insulated wire connected with the main circuit in a system of electric gas-lighting, the extra spark produced on breaking the circuit of which is employed for electrically igniting gas jets.
- COILS, ARMATURE, OF DYNAMO-ELECTRIC MACHINE—The coils, strips or bars that are wound or placed on the armature core.
- COMMERCIAL EFFICIENCY—(See Efficiency, Commercial).
- COMMERCIAL EFFICIENCY OF DYNAMO—(See Efficiency, Commercial, of Dynamo).

**COMMUTATION, DIAMETER OF**—In a dynamo-electric machine a diameter on the commutator cylinder on one side of which the differences of potential, produced by the movement of the coils through the magnetic field, tend to produce a current in a direction opposite to those on the other side.

**COMMUTATOR**—In general, a device for changing the direction of an electric current.

**COMMUTATOR, DYNAMO-ELECTRIC MACHINE**—That part of a dynamo-electric machine which is designed to cause the alternating currents produced in the armature to flow in one and the same direction in the external circuit.

**COMPASS, AZIMUTH**—A compass used by mariners for measuring the horizontal distance of the sun or stars from the magnetic meridian. A mariner's Compass.

**COMPASS, INCLINATION**—A magnetic needle moving freely in a single vertical plane, and employed for determining the angle of dip at any place.

**COMPONENT, HORIZONTAL, OF EARTH'S MAGNETISM**—That portion of the earth's directive force which acts in a horizontal direction. That portion of the earth's magnetic force which acts to produce motion in a compass needle free to move in a horizontal plane only.

**COMPOUND-WINDING OF DYNAMO-ELECTRIC MACHINES**—(See Winding, Compound, of Dynamo-Electric Machines).

**COMPOUND-WOUND DYNAMO-ELECTRIC MACHINE**—(See Machine, Dynamo-Electric, Compound-Wound).

- COMPOUND-WOUND MOTOR—(See Motor, Compound-Wound).
- CONDENSER—A device for increasing the capacity of an insulated conductor by bringing it near another insulated earth-connected conductor, but separated therefrom by any medium that will readily permit induction to take place through its mass.
- CONDENSER, CAPACITY OF—The quantity of electricity in coulombs a condenser is capable of holding before its potential in volts is raised a given amount.
- CONDUCT—To pass electricity through conducting substances.
- CONDUCTANCE—A word sometimes used in place of conducting power. Conductivity.
- CONDUCTING POWER—(See Power, Conducting).
- CONDUCTION, ELECTROLYTIC—A term sometimes employed to indicate the passage of electricity through an electrolyte.
- CONDUCTIVITY, ELECTRIC—The reciprocal of electric resistance.
- CONDUCTOR—A substance which will permit the so-called passage of an electric current. A substance which possesses the ability of determining the direction in which electricity shall pass through the ether or other dielectric surrounding it.
- CONDUCTOR, LIGHTNING—A term sometimes used for a lightning rod.



**CONDUCTORS, SERVICE**—Conductors employed in systems of incandescent lighting connected to the street mains and to the electric apparatus placed in the separate buildings or areas to be lighted.

**CONDUIT, UNDERGROUND ELECTRIC**—An underground passageway or space for the reception of electric wires or cables.

**CONNECT**—To place or bring into electric contact.

**CONNECTOR**—A device for readily connecting or joining the ends of two or more wires.

**CONSEQUENT POLES**—(See Poles, Consequent).

**CONSERVATION OF ENERGY**—(See Energy, Conservation of).

**CONSTANT-CURRENT**—(See Current, Constant).

**CONSTANT-CURRENT CIRCUIT**—(See Circuit, Constant Current).

**CONSTANT POTENTIAL**—(See Potential, Constant).

**CONSTANT-POTENTIAL CIRCUIT**—(See Circuit, Constant-Potential).

**CONTACT-BREAKER, AUTOMATIC**—A device for causing an electric current to rapidly make and break its own circuit.

**CONTACT, METALLIC**—A contact of a metallic conductor produced by its coming into firm connection with another metallic conductor.

**CONTACT, SLIDING**—A contact connected with one part of a circuit that closes or completes an electric circuit by being slid over a conductor connected with another part of the circuit.

**CONTROLLER**—A magnet, in the Thomson-Houston system of automatic regulation, whose coils are traversed by the main current, and by means of which the regulator magnet is automatically thrown into or out of the main circuit on changes in the strength of the current passing.

**CONVECTION, ELECTROLYTIC**—A term proposed by Helmholtz to explain the apparent conduction of electricity by an electrolyte, without consequent decomposition.

**CONVERTER**—The inverted induction coil employed in systems of distribution by means of alternating currents. A term sometimes used instead of transformer.

**CONVERTER, EFFICIENCY OF**—The efficiency of a transformer.

**CONVERTER, HEDGEHOG**—A form of transformer. (See Transformer, Hedgehog).

**COPPER, STRAP**—Copper conductors in the form of straps or flat bars.

**CORD, ELECTRIC**—A flexible, insulated electric conductor, generally containing at least two parallel wires.

**CORE, ARMATURE, H**—An armature core the shape of the letter H, generally known as the shuttle armature, and sometimes as the girder armature.

**CORE, ARMATURE, LAMINATION OF**—The subdivision of the core of the armature of a dynamo-electric machine into separate insulated plates or strips for the purpose of avoiding eddy or Foucault currents.

**CORE, ARMATURE, OF DYNAMO-ELECTRIC MACHINE**—The iron core, on, or around, which the armature coils of a dynamo-electric machine are wound or placed.

**CORE, ARMATURE, VENTILATION OF**—Means for passing air through the armature cores of dynamo-electric machines in order to prevent undue accumulation of heat.

**CORE, LAMINATED**—A core of iron which has been divided or laminated, in order to avoid the injurious production of Foucault or eddy currents.

**CORE, STRANDED, OF CABLE**—The conducting wire or core of a cable formed of a number of separate conductors or wires instead of a single conductor of the same weight per foot as the combined conductors.

**CORED CARBONS**—(See Carbons, Cored).

**COULOMB**—Such a quantity of electricity as would pass in one second in a circuit whose resistance is one ohm, under an electromotive force of one volt.

**COUNTER-ELECTROMOTIVE FORCE**—(See Force, Electromotive, Counter).

**COUPLE, ASTATIC**—Two magnets of exactly equal strength so placed one over the other in the same vertical plane as to completely neutralize each other.

**COUPLE, MAGNETIC**—The couple which tends to turn a magnetic needle, placed in the earth's field, into the plane of the magnetic meridian.

**COUPLE, THERMO-ELECTRIC**—Two dissimilar metals which, when connected at their ends only, so as to form a completed electric circuit, will produce a difference of potential, and hence an electric current, when one of the ends is heated more than the other.

**COUPLE, VOLTAIC**—Two materials, usually two dissimilar metals, capable of acting as an electric source when dipped in an electrolyte, or capable of producing a difference of electric potential by mere contact.

**CROSS ARM**—(See Arm, Cross).

**CROSS, ELECTRIC**—A connection, generally metallic, accidentally established between two conducting lines.

**CRUCIBLE, ELECTRIC**—A crucible in which the heat of the voltaic arc, or of electric incandescence, is employed either to perform difficult fusions, or for the purpose of effecting the reduction of metals from their ores or the formation of alloys.

**CUP, POROUS**—A porous cell.

**CURRENT, ALTERNATING**—A current which flows alternately in opposite directions. A current whose direction is rapidly reversed.

**CURRENT, CONSTANT**—A current that continues to flow for some time without varying in strength.

**CURRENT, CONTINUOUS**—An electric current which flows in one and the same direction.

**CURRENT DENSITY**—The current of electricity which passes in any part of a circuit as compared with the area of cross-section of that part of the circuit.

**CURRENT, DIRECT**—A current constant in direction, as distinguished from an alternating current.

**CURRENT, DIRECTION OF**—The direction an electric current is assumed to take out from one pole of any source through the circuit and its translating devices back to the source through its other pole.

**CURRENT, ELECTRIC**—The quantity of electricity which passes per second through any conductor or circuit.

The rate at which a definite quantity of electricity passes or flows through a conductor or circuit.

**CURRENT, GENERATION OF, BY DYNAMO-ELECTRIC MACHINE**—The difference of potential developed in the armature coils by the cutting of the lines of magnetic force of the field by the coils, during the rotation of the armature.

**CURRENT, INDUCED**—The current produced in a conductor by cutting lines of force.

**CURRENT, PULSATORY**—A current, the strength of which changes suddenly.

**CURRENT, ROTATING**—A term applied to the current which results by combining a number of alternating currents, whose phases are displaced with respect to one another.

**CURRENT STRENGTH**—The product obtained by dividing the electromotive force by the resistance.

The current strength for a constant current according to Ohm's law is—

$$C \text{ equals } \frac{E}{R}$$

**CURRENT, TO TRANSFORM A**—To change the electromotive force of a current by its passage through a converter or transformer. To convert a current.

**CURRENT, UNIT STRENGTH OF**—Such a strength of current that when passed through a circuit one centimetre in length, arranged in an arc one centimetre in radius, will exert a force of one dyne on a unit magnet pole placed at the center. This absolute unit is equal to ten amperes or practical units of current.

**CURRENTS, CONVERTED**—Electric currents changed either in their electromotive force or in their strength, by passage through a converter or transformer.

**CURRENTS, EDDY**—Useless currents produced in the pole pieces, armatures, field-magnet cores of dynamo-electric machines or motors, or other metallic masses, either by their motion through magnetic fields, or by variations in the strength of electric currents flowing near them.

**CURRENTS, EXTRA**—Currents produced in a circuit by the induction of the current on itself on the opening or closing of the circuit.

**CURRENTS, FOUCAULT**—A name sometimes applied to eddy currents, especially in armature cores.

**CURRENTS, HEATING EFFECTS OF**—The heat produced by the passage of an electric current through any circuit.

**CURRENTS, SIMPLE PERIODIC**—Currents, the flow of which is variable, both in strength and duration, and in which the flow of electricity, passing any section of the conductor, may be represented by a simple periodic curve.

**CURVE, CHARACTERISTIC**—A diagram in which a curve is employed to represent the ratio of volts and amperes in a dynamo or motor.

**CURVE, CHARACTERISTIC, OF PARALLEL TRANSFORMER**—A curve so drawn that its ordinate and abscissa at any point represent the secondary electromotive force and the secondary current of a multiple connected transformer, when the resistance of the secondary circuit has a certain definite value.

**CURVE, PERMEABILITY**—A curve representing the magnetic permeability of a magnetic substance.

**CURVE, SIMPLE-HARMONIC**—The curve which results when a simple-harmonic motion in one line is compounded with a uniform motion in a straight line, at right angles thereto.

A harmonic curve is sometimes called a curve of sines because the abscissas of the curve are proportional to the times, while the ordinates are proportional to the sines of the angles, which are themselves proportional to the times.

**CUT-OUT, A**—A device by means of which an electro-receptive device or loop may be thrown out of the circuit of an electric source.

**CUT-OUT, AUTOMATIC, FOR MULTIPLE-CONNECTED ELECTRO-RECEPTIVE DEVICES**—A device for automatically cutting an electro-receptive device, such as a lamp, out of the circuit of the leads.

Automatic cut-outs for incandescent lamps, when connected to the leads in multiple-arc, consist of strips of readily melted metal called safety-fuses, which on the passage of an excessive current fuse, and thus automatically break the circuit in that particular branch.

**CUTTING LINES OF FORCE**—(See Force, Lines of Cutting)

**CYCLE**—A period of time within which a certain series of phenomena regularly recur, in the same order.

**CYCLE, MAGNETIC**—A single round of magnetic changes to which a magnetizable substance, such as a piece of iron, is subjected when it is magnetized from zero to a certain maximum magnetization, then decreased to zero, reversed and carried to a negative maximum, and then decreased again to zero.

## D

**DAMPER**—A metallic cylinder provided in an induction coil so as to partially or completely surround the iron core, for the purpose of varying the intensity of the currents induced in the secondary.

**DAMPING**—The act of stopping vibratory motion such as bringing a swinging magnetic needle quickly to rest, so as to determine the amount of its deflection, without waiting until it comes to rest after repeated swingings to and fro.

**DEAD-BEAT**—Such a motion of a galvanometer needle in which the needle moves sharply over the scale from point to point and comes quickly to rest.

**DECLINATION**—The variation of a magnetic needle from the true geographical north.

**DECLINATION, ANGLE OF**—The angle which measures the deviation of the magnetic needle to the east or west of the true geographical north.



**DECOMPOSITION, ELECTRIC**—Chemical decomposition by means of an electric discharge or current.

**DEMAGNETIZATION**—A process, generally directly opposite to that for producing a magnet, by means of which the magnet may be deprived of its magnetism.

**DENSITY, MAGNETIC**—The strength of magnetism as measured by the number of lines of magnetic force that pass through a unit area of cross-section of the magnet, i. e., a section taken at right angles to the lines of force.

**DEPOSIT. ELECTRO-METALLURGICAL**—The deposit of metal obtained by any electro-metallurgical process.

**DETECTOR, GROUND**—In a system of incandescent lamp distribution, a device placed in the central station, for showing by the candle-power of a lamp the approximate location of a ground on the system.

**DEVICE, ELECTRO-RECEPTIVE**—Various devices placed in an electric circuit, and energized by the passage through them of the electric current.

**DEVICE, TRANSLATING**—A term embracing electro-receptive and magneto-receptive devices. (See Device, Electro-Receptive).

**DIAMAGNETIC**—The property possessed by substances like bismuth, phosphorus, antimony, zinc and numerous others, of being apparently repelled when placed between the poles of powerful magnets.

**DIELECTRIC**—A substance which permits induction to take place through its mass.

**DIELECTRIC, POLARIZATION OF**—A molecular strain produced in the dielectric of a Leyden jar or other condenser, by the attraction of the electric charges on its opposite faces, or by the electrostatic stress.

**DIMMER**—A choking coil or resistance employed for regulating the potential of the feeders, which usually carry incandescent lamps.

**DIP, MAGNETIC**—The deviation of a magnetic needle from a true horizontal position. The inclination of the magnetic needle towards the earth.

**DIRECT CURRENT**—(See Current, Direct).

**DIRECT-CURRENT ELECTRIC MOTOR**—(See Motor, Electric, Direct-Current).

**DIRECTION OF LINES OF FORCE**—(See Force, Lines of, Direction of).

**DISC, ARAGO'S**—A disc of copper or other non-magnetic metallic substance, which, when rapidly rotated under a magnetic needle, supported independently of the disc, causes the needle to be deflected in the direction of rotation, and, when the velocity of the disc is sufficiently great, to rotate with it.

**DISC, FARADAY'S**—A metallic disc movable in a magnetic field on an axis parallel to the direction of the field.

**DISCHARGE**—The equalization of the difference of potential between the terminals of a condenser or source, on their connection by a conductor.

**DISCHARGE, BRUSH**—A faintly luminous discharge that occurs from a pointed positive conductor.

**DISCHARGE, DISRUPTIVE**—A sudden, and more or less complete, discharge that takes place across an intervening non-conductor or dielectric.

**DISCHARGE, LUMINOUS EFFECTS OF**—The luminous phenomena attending and produced by an electric discharge.

**DISCHARGE, OSCILLATING**—A number of successive discharges and recharges which occur on the disruptive discharge of a Leyden jar, or condenser.

**DISCHARGE, VELOCITY OF**—The time required for the passage of a discharge through a given length of conductor.

**DISCHARGER, UNIVERSAL**—An apparatus for sending the discharge of a powerful Leyden battery or condenser in any desired direction.

**DISCONNECT**—To break or open an electric circuit.

**DISTANCE, SPARKING**—The distance at which electrical sparks will pass through an intervening air space.

**DISTILLATION, ELECTRIC**—The distillation of a liquid in which the effects of heat are aided by an electrification of the liquid.

**DISTRIBUTION, CENTER OF**—In a system of multiple-distribution, any place where branch cut-outs and switches are located in order to control communication therewith. The electrical center of a system of distribution as regards the conducting network.

**DISTRIBUTION OF ELECTRICITY**—(See Electricity, Distribution of).

DISTRIBUTION OF ELECTRICITY BY CONSTANT POTENTIAL CIRCUIT—(See Electricity, Multiple Distribution of, by Constant Potential Circuit).

DOUBLE-CARBON ARC LAMP—(See Lamp, Electric Arc, Double-Carbon).

DOUBLE-FLUID VOLTAIC CELL—(See Cell, Voltaic, Double-Fluid).

DOUBLE-TOUCH, MAGNETIZATION BY—A method for producing magnetization by the simultaneous touch of two magnet poles.

DROP, ANNUNCIATOR—A movable signal operated by an electro-magnet, and placed on an annunciator, the dropping of which indicates the closing or opening of the circuit with which the electro-magnet is connected.

DROP, AUTOMATIC—A device for automatically closing the circuit of a bell and holding it closed until stopped by resetting a drop.

DRUM ARMATURE—(See Armature, Drum).

DRY VOLTAIC CELL—(See Cell, Voltaic, Dry).

DUPLEX TELEGRAPHY—(See Telegraphy, Duplex).

DYEING, ELECTRIC—The application of electricity either to the reduction or the oxidation of the salts used in dyeing.

DYNAMICS, ELECTRO—That branch of electric science which treats of the action of electric currents on one another and on themselves or on magnets.

DYNAMO—The name frequently applied to a dynamo-electric machine used as a generator.

**DYNAMO, COMPOSITE FIELD**—A dynamo whose field coils are series and separately excited.

**DYNAMO, COMPOUND-WOUND**—A compound-wound dynamo-electric machine. (See Machine, Dynamo-Electric, Compound-Wound).

**DYNAMO-ELECTRIC MACHINE, BI-POLAR**—(See Machine, Dynamo-Electric, Bi-Polar).

**DYNAMO-ELECTRIC MACHINE, MULTIPOLAR**—(See Machine, Dynamo-Electric, Multipolar).

**DYNAMO, INDUCTOR**—A dynamo-electric machine for alternating currents in which the differences of potential causing the currents are obtained by magnetic changes in the cores of the armature and field coils by the movement past them of laminated masses of iron inductors.

**DYNAMO, MULTIPHASE**—A polyphase dynamo. (See Dynamo, Polyphase. Dynamo, Rotating Current).

**DYNAMO, POLYPHASE**—A dynamo producing two or more currents differing in phase. A name sometimes applied to a rotating current dynamo. (See Dynamo, Rotating Current).

**DYNAMO, PYROMAGNETIC**—A name sometimes applied to a pyromagnetic generator.

**DYNAMO, SEPARATELY EXCITED**—A separately-excited dynamo-electric machine.

**DYNAMO, SERIES**—A series-wound dynamo-electric machine.

**DYNAMO, SHUNT**—A shunt-wound dynamo-electric machine.

**DYNAMOMETER, ELECTRO**—A form of galvanometer for the measurement of electric currents.

**DYNE**—The unit of force. The force which in one second can impart a velocity of one centimetre per second to a mass of one gramme.

## E

**E**.—A contraction sometimes used for earth. A contraction sometimes used for electromotive force, or E. M. F., as in the well-known formula for Ohm's law,

$$C \text{ equals } \frac{E}{R}$$

**E. M. F.**—A contraction generally used for electromotive force.

**EARTH**—A fault in a telegraphic or other line, caused by accidental contact of the line with the ground or earth, or with some conductor connected with the latter.

**EBONITE**—A tough, hard, black substance, composed of india rubber and sulphur, which possesses high powers of insulation and of specific inductive capacity.

**EDDY CURRENTS**—(See Currents, Eddy).

**EEL, ELECTRIC**—An eel possessing the power of giving powerful electric shocks. The *gymnotus electricus*.

**EFFECT, EDISON**—An electric discharge which occurs between one of the terminals of the incandescent filament of an electric lamp, and a metallic plate placed near the filament but disconnected therefrom, as soon as a certain difference of potential is reached between the lamp terminals.

**EFFECT, FERRANTI**—An increase in the electromotive force, or difference of potential, of mains or conductors towards the end of the same farthest from the terminals that are connected with a source of constant potential.

**EFFECT, HALL**—A transverse electromotive force, produced by a magnetic field in substances undergoing electric displacement.

**EFFECT, JOULE**—The heating effect produced by the passage of an electric current through a conductor, arising merely from the resistance of the conductor.

**EFFECT, PELTIER**—The heating effect produced by the passage of an electric current across a thermo-electric junction or surface of contact between two different metals.

**EFFECT, THERMO-ELECTRIC**—The production of an electromotive force at a thermo-electric junction by a difference of temperature between that junction and the other junction of the thermo-electric couple.

**EFFECT, THOMSON**—The production of an electromotive force in unequally heated homogeneous conducting substances. A term also applied to the increase or decrease in the differences of temperature in an unequally heated conductor, produced by the passage of an electrical current through the conductor.

**EFFECT, VOLTAIC**—A difference of potential observed at the point of contact of two dissimilar metals.

**EFFICIENCY, COMMERCIAL**—The useful or available energy produced divided by the total energy absorbed by any machine or apparatus.

The Commercial Efficiency equals

$$\frac{W}{M} \text{ equals } \frac{W}{W+w+m},$$

when  $W$  equals the useful or available energy;  $M$  equals the total energy;  $w$ , the energy absorbed by the machine, and  $m$ , the stray power, or power lost in friction of bearings, etc., air friction, eddy currents, etc.

**EFFICIENCY, COMMERCIAL, OF DYNAMO**—The useful or available electrical energy in the external circuit, divided by the total mechanical energy required to drive the dynamo that produced it.

**EFFICIENCY, ELECTRIC**—The useful or available electrical energy of any source, divided by the total electrical energy.

The electric efficiency equals  $\frac{W}{W+w}$ , where  $W$ , equals

the useful or available electrical energy, and  $w$ , the electrical energy absorbed by the machine.

**EFFICIENCY OF CONVERSION**—The ratio between the energy present in any result and the energy expended in producing that result.

**EFFICIENCY, QUANTITY, OF STORAGE BATTERY**—The ratio of the number of ampere-hours, taken out of a storage or secondary battery, to the number of ampere-hours put in the battery in charging it.



**EFFICIENCY, REAL, OF STORAGE BATTERY**—The ratio of the number of watt-hours taken out of a storage battery, to the number of watt-hours put into the battery in charging it.

**ELECTRIC**—Pertaining to electricity.

**ELECTRIC ARC**—(See Arc, Electric).

**ELECTRIC BATTERY**—(See Battery, Electric).

**ELECTRIC BOBBIN**—(See Bobbin, Electric).

**ELECTRIC BUZZER**—(See Buzzer, Electric).

**ELECTRIC CANDLE**—(See Candle, Electric).

**ELECTRIC CHARGE**—(See Charge, Electric).

**ELECTRIC CIRCUIT**—(See Circuit, Electric).

**ELECTRIC CLOCK**—(See Clock, Electric).

**ELECTRIC COIL**—See Coil, Electric).

**ELECTRIC CURRENT**—(See Current, Electric).

**ELECTRIC EFFICIENCY**—(See Efficiency, Electric).

**ELECTRIC ENERGY**—(See Energy, Electric).

**ELECTRIC FIELD**—(See Field, Electro Magnetic.)

**ELECTRIC FORCE**—(See Force, Electric).

**ELECTRIC FURNACE**—See Furnace, Electric).

**ELECTRIC FUSE**—(See Fuse, Electric).

**ELECTRIC HEAT**—(See Heat, Electric).

**ELECTRIC HORSE POWER**—(See Power, Horse, Electric)

**ELECTRIC INSULATION**—(See Insulation, Electric).

**ELECTRIC LAMP, ARC**—(See Lamp, Electric, Arc).

- ELECTRIC LAMP, INCANDESCENT—(See Lamp, Electric, Incandescent).
- ELECTRIC LAUNCH—(See Launch, Electric).
- ELECTRIC LIGHT—(See Light, Electric).
- ELECTRIC LIGHTING, CENTRAL STATION—(See Station, Central).
- ELECTRIC LOCOMOTIVE—(See Locomotive, Electric).
- ELECTRIC METER—(See Meter, Electric).
- ELECTRIC MOTOR—(See Motor, Electric).
- ELECTRIC OSCILLATIONS—(See Oscillations, Electric).
- ELECTRIC POTENTIAL—(See Potential, Electric).
- ELECTRIC POWER—(See Power, Electric).
- ELECTRIC RESISTANCE—(See Resistance, Electric).
- ELECTRIC RESONANCE—(See Resonance, Electric).
- ELECTRIC SHOCK—(See Shock, Electric).
- ELECTRIC TRAMWAY—(See Tramway, Electric).
- ELECTRIC WELDING—(See Welding, Electric).
- ELECTRIC WHIRL—(See Whirl, Electric).
- ELECTRIC WORK—(See Work, Electric).
- ELECTRICALLY—In an electrical manner.
- ELECTRICIAN—One versed in the principles and applications of electrical science.
- ELECTRICITY—The name given to the unknown thing, matter or force, or both, which is the cause of electric phenomena.
- Electricity, no matter how produced, is believed to be one and the same thing.

**ELECTRICITY, ANIMAL**--Electricity produced during life in the bodies of animals.

All animals produce electricity during life. In some, such as the electric eel or torpedo, the amount is comparatively large. In others, it is small.

**ELECTRICITY, ATMOSPHERIC**--The free electricity almost always present in the atmosphere.

**ELECTRICITY, ATMOSPHERE, ORIGIN OF**--The exact cause of the free electricity of the atmosphere is unknown.

**ELECTRICITY, CONTACT**--Electricity produced by the mere contact of dissimilar metals.

**ELECTRICITY, DISTRIBUTION OF**--Various combinations of electric sources, circuits and electro-receptive devices whereby electricity generated by the sources is carried or distributed to more or less distant electro-receptive devices by means of the various circuits connected therewith.

**ELECTRICITY, DISTRIBUTION OF, BY ALTERNATING CURRENTS**--A system of electric distribution by the use of alternating currents.

**ELECTRICITY, DISTRIBUTION OF, BY CONSTANT CURRENTS**--A system for the distribution of electricity by means of direct, i. e., continuous, steady or non-alternating currents, as distinguished from alternating currents.

**ELECTRICITY, DOUBLE FLUID HYPOTHESIS OF**--A hypothesis which endeavors to explain the causes of electric phenomena by the assumption of the existence of two different electric fluids.

- ELECTRICITY, FRICTIONAL**—Electricity produced by friction.
- ELECTRICITY, GALVANIC**—A term used by some in place of voltaic electricity.
- ELECTRICITY, HERTZ'S THEORY OF ELECTRO-MAGNETIC RADIATIONS OR WAVES**—A theory, now generally accepted, which regards light as one of the effects of electro-magnetic pulsations or waves.
- ELECTRICITY, MAGNETO**—Electricity produced by the motion of magnets past conductors, or of conductors past magnets. Electricity produced by magneto-electric induction.
- ELECTRICITY, MULTIPLE-DISTRIBUTION OF, BY CONSTANT POTENTIAL CIRCUIT**—Any system for the distribution of continuous currents of electricity in which the electro-receptive devices are connected to the leads in multiple-arc or parallel.
- ELECTRICITY, NEGATIVE**—One of the phases of electrical excitement. The kind of electric charge produced on resin when rubbed with cotton.
- ELECTRICITY, POSITIVE**—One of the phases of electric excitement. The kind of electric charge produced on cotton when rubbed against resin.
- ELECTRICITY, PYRO**—Electricity developed in certain crystalline bodies by unequally heating or cooling them.
- ELECTRICITY, SERIES DISTRIBUTION OF, BY CONSTANT CURRENT CIRCUIT**—Any system for the distribution of constant currents of electricity in which the electro-receptive devices are connected to the line-wire or circuit in series.

**ELECTRICITY, SINGLE-FLUID HYPOTHESIS OF**—A hypothesis which endeavors to explain the cause of electrical phenomena by the assumption of the existence of a single electric fluid.

**ELECTRICITY, STATIC**—A term applied to electricity produced by friction.

**ELECTRICITY, STORAGE OF**—A term improperly employed to indicate such a storage of energy as will enable it to directly reproduce electric energy.

**ELECTRICITY, THERMO**—Electricity produced by differences of temperature at the junctions of dissimilar metals.

**ELECTRICITY, UNIT QUANTITY OF**—The quantity of electricity conveyed by unit current per second.

The practical unit quantity of electricity is the coulomb, which is the quantity conveyed by a current of one ampere in one second.

**ELECTRICITY, VOLTAIC**—Differences of potential produced by the agency of a voltaic cell or battery.

**ELECTRIFICATION**—The act of becoming electrified. The production of an electric charge.

**ELECTRIFY**—To endow with electrical properties.

**ELECTROCUTION**—Capital punishment by means of electricity.

**ELECTRODE**—Either of the terminals of an electric source.

**ELECTRODE, NEGATIVE**—The electrode connected with the negative pole of an electric source.

**ELECTRODE, POSITIVE**—The electrode connected with the positive pole of an electric source.

**ELECTRODE, SPONGE**—A moistened sponge connected to one of the terminals of an electric source and acting as the electro-therapeutic electrode.

**ELECTRODES**—The terminals of an electric source.

**ELECTRODES, CARBON, FOR ARC-LAMPS**—Rods of artificial carbon employed in arc lamps.

These are more properly called simply arc-lamp carbons.

**ELECTRODES, CORED**—Carbon electrodes of a cylindrical shape provided with a central cylinder of softer carbon.

**ELECTROLIER**—A chandelier for holding electric lamps, as distinguished from a chandelier for holding gas-lights.

**ELECTROLYSIS**—Chemical decomposition effected by means of an electric current.

**ELECTROLYTE, POLARIZATION OF**—The formation of molecular groups or chains, in which the poles of all the molecules of any chain are turned in the same direction, viz: with their positive poles facing the negative plate, and their negative poles facing the positive plate.

**ELECTROLYTIC OR ELECTROLYTICAL**—Pertaining to electrolysis.

**ELECTROLYTIC CELL**—(See Cell, Electrolytic).

**ELECTROLYTIC DECOMPOSITION**—(See Decomposition, Electrolytic).

**ELECTRO-MAGNET**—(See Magnet, Electro).

**ELECTRO-METALLURGY**—(See Metallurgy, Electro).

**ELECTROMETER**—An apparatus for measuring differences of potential.

**ELECTROMETER, CAPILLARY**—An electrometer in which a difference of potential is measured by the movement of a drop of sulphuric acid in a tube filled with mercury.

**ELECTROMETER, QUADRANT**—An electrometer in which an electrostatic charge is measured by the attractive and repulsive force of four plates or quadrants, on a light needle of aluminum suspended within them.

**ELECTROMOTIVE FORCE**—(See Force, Electromotive).

**ELECTROMOTIVE FORCE, BACK OR COUNTER**—(See Force, Electromotive, Back).

**ELECTROPHORUS**—An apparatus for the production of electricity by electrostatic induction.

**ELECTRO-PLATING**—(See Plating, Electro).

**ELECTRO-PLATING BATH**—(See Bath, Electro-Plating).

**ELECTROPOION LIQUID**—(See Liquid, Electropoion).

**ELECTROSCOPE**—An apparatus for showing the presence of an electric charge, or for determining its sign, whether positive or negative, but not for measuring its amount or value.

**ELECTROSCOPE, GOLD-LEAF**—An electroscope in which two leaves of gold are used to detect the presence of an electric charge, or to determine its character whether positive or negative.

**ELECTROSCOPE, PITH-BALL**—An electroscope which shows the presence of a charge by the repulsion of two similarly charged pith-balls.

**ELECTROSTATIC CAPACITY**—(See Capacity, Electrostatic).

**ELECTROTONUS**—A condition of altered functional activity which occurs in a nerve when subjected to the action of an electric current.

**ELECTROTYPE**—A type, cast or impression of an object obtained by means of electro-metallurgy. (See Metallurgy, Electro. Electrotyping).

**ELECTROTYPING, OR THE ELECTROTYPE PROCESS**—Obtaining casts or copies of objects by depositing metals in molds by the agency of electric currents.

The molds are made of wax, or other plastic substance, rendered conducting by coating it with powdered plumbago.

**ELEMENT, NEGATIVE, OF A VOLTAIC CELL**—That element or plate of a voltaic cell into which the current passes from the exciting fluid of the cell. The plate that is not acted on by the electrolyte during the generation of current by the cell.

**ELEMENT, POSITIVE**—That element or plate of a voltaic cell from which the current passes into the exciting fluid of the cell. The element of a voltaic couple which is acted on by the exciting fluid of the cell.

**ELEMENT, THERMO-ELECTRIC**—One of the two metals or substances which form a thermo-electric couple.

**ELEMENT, VOLTAIC**—One of the two metals or substances which form a voltaic couple.

**ELEVATOR, ELECTRIC**—An elevator operated by electric power.



**ELONGATION, MAGNETIC**—An increase in the length of a bar of iron on its magnetization.

**ENDOSMOSE, ELECTRIC**—Differences in the level of liquids capable of mixing through the pores of a diaphragm separating them, produced by the flow of an electric current through the liquid.

**ENERGY**—The power of doing work.

**ENERGY, CONSERVATION OF**—The indestructibility of energy.

The total quantity of energy in the universe is unalterable.

**ENERGY, DISSIPATION OF**—The expenditure or loss of available energy.

**ENERGY, ELECTRIC**—The power which electricity possesses of doing work.

**ENERGY, ELECTRIC, TRANSMISSION OF**—The transmission of mechanical energy between two distant points connected by an electric conductor, by converting the mechanical energy into electrical energy at one point, sending the current so produced through the conductor, and reconverting the electrical into mechanical energy at the other point.

**ENERGY, KINETIC**—Energy which is due to motion as distinguished from potential energy.

**ENERGY, POTENTIAL**—Stored energy. Potency, or capability of doing work.

Energy possessing the power or potency of doing work, but not actually performing such work.

The capacity for doing work possessed by a body at rest, arising from its position as regards the earth, or from the position of its atoms as regards other atoms, with which it is capable of combining.

**ENERGY, RADIANT**—Energy transferred to or charged on the universal ether.

**ENERGY, STATIC**—A term used to express the energy possessed by a body at rest, resulting from its position as regards other bodies in contradistinction to kinetic energy or the energy possessed by a body whose atoms, molecules or masses are in actual motion.

Potential energy.

**EQUATOR, MAGNETIC**—The magnetic parallel or circle on the earth's surface where a magnetic needle, suspended so as to be free to move in a vertical as well as a horizontal plane, remains horizontal.

**EQUIVALENT, ELECTRO-CHEMICAL**—A number representing the weight in grammes of an elementary substance liberated during electrolysis by the passage of one coulomb of electricity.

**EQUIVALENT, JOULE'S**—The mechanical equivalent of heat.

**ERG**—The unit of work, or the work done when unit force is overcome through unit distance. The work accomplished when a body is moved through a distance of one centimetre with the force of one dyne.

**ETHER**—The tenuous, highly elastic fluid that is assumed to fill all space, and by vibrations or waves in which light and heat are transmitted.

**EVAPORATION, ELECTRIC**—The formation of vapors at the surfaces of substances by the influence of negative electrification.

**EVAPORATION, ELECTRIFICATION BY**—An increase in the difference of potential existing in a mass of vapor attending its sudden condensation.

**EXCHANGE, TELEPHONIC, SYSTEM OF**—A combination of circuits, switches and other devices, by means of which any one of a number of subscribers connected with a telephonic circuit, or a neighboring telephonic circuit or circuits, may be placed in electrical communication with any other subscriber connected with such circuit or circuits.

**EXPLODER, ELECTRIC MINE**—A small magneto-electric machine used to produce the currents of high electro-motive force employed in the direct firing of blasts.

**EXPLODER, ELECTRO-MAGNETIC**—(See Exploder, Electric Mine).

**EXPLORER, MAGNETIC**—A small, flat coil of insulated wire, used, in connection with the circuit of a telephone, to determine the position and extent of the magnetic leakage of a dynamo-electric machine or other similar apparatus.

## F

**FAHRENHEIT'S THERMOMETER SCALE**—(See Scale, Thermometer, Fahrenheit's).

**FALL OF POTENTIAL**—(See Potential, Fall of).

**FAN GUARD**—(See Guard, Fan).

**FARAD**—The practical unit of electric capacity.

Such a capacity of a conductor or condenser that one coulomb of electricity is required to produce in the conductor or condenser a difference of potential of one volt.

**FARAD. MICRO**—The millionth part of a farad.

**FAULT**—Any failure in the proper working of a circuit due to ground contacts, cross-contacts or disconnections.

**FEED, CLOCKWORK, FOR ARC LAMPS**—An arrangement of clockwork for obtaining a uniform feed motion of one or both electrodes of an arc lamp.

**FEED, TO**—To supply with an electric current, as by a dynamo or other source.

**FEEDER**.—One of the conducting wires or channels through which the current is distributed to the main conductors.

**FEEDER, STANDARD OR MAIN**—The main feeder to which the standard pressure indicator is connected, and whose pressure controls the pressure at the ends of all the other feeders.

**FEEDERS**—In a system of distribution by constant potential, as in incandescent electric lighting, the conducting wires extending between the bus-wires or bars, and the junction boxes.

**FEET, AMPERE**—The product of the current in amperes by the distance in feet through which that current passes.

**FIBRE, QUARTZ**—A fibre suitable for suspending galvanometer needles, etc., made of quartz.

**FIBRE, VULCANIZED**—A variety of insulating material suitable for purposes not requiring the highest insulation.

**FIELD, AIR**—That portion of a magnetic field in which the lines of force pass through air only.

**FIELD, ALTERNATING**—An electrostatic or magnetic field the positive direction of the lines of force in which is alternately reversed or changed in direction.

**FIELD, ALTERNATING MAGNETIC**—A magnetic field the direction of whose lines of force is alternately reversed.

**FIELD, DENSITY OF**—The number of lines of force that pass through any field, per unit of area of cross-section.

**FIELD, ELECTRO-MAGNETIC**—The space traversed by the lines of magnetic force produced by an electro-magnet.

**FIELD, ELECTROSTATIC**—The region of electrostatic influence surrounding a charged body.

**FIELD, EXCITER OF**—In a separately excited dynamo-electric machine, the dynamo-electric machine, voltaic battery, or other electric source employed to produce the field of the field magnets.

**FIELD, INTENSITY OF**—The strength of a field as measured by the number of lines of force that pass through it per unit of area of cross-section.

**FIELD, MAGNETIC**—The region of magnetic influence surrounding the poles of a magnet.

A space or region traversed by lines of magnetic force.

A place where a magnetic needle, if free to move, will take up a definite position, under the influence of the lines of magnetic force.

**FIELD, MAGNETIC, OF AN ELECTRIC CURRENT**—The magnetic field surrounding a circuit through which an electric current is flowing.

An electric current produces a magnetic field.

**FIELD, MAGNETIC, PULSATORY**—A field, the strength of which pulsates in such manner as to produce oscillatory currents by induction.

**FIELD, MAGNETIC, STRAY**—That portion of the field of a dynamo-electric machine which is not utilized for the development of differences of potential in the armature, because its lines of force do not pass through the armature.

**FIELD, MAGNETIC, STRENGTH OF**—The dynamic force acting on a free magnetic pole, placed in a magnetic field.

**FIELD, ROTATING CURRENT**—A magnetic field produced by means of a rotating current.

**FIGURES, MAGNETIC**—A name sometimes applied to the groupings of iron filings on a sheet of paper so held in a magnetic field as to be grouped or arranged under the influence of the lines of force of the same.

**FILAMENT OF INCANDESCENT ELECTRIC LAMP**—(See Lamp, Incandescent Electric, Filament of).

**FILAMENTS, FLASHED**—Filaments for an incandescent lamp, that have been subjected to the flashing process.

**FINDER, RANGE, ELECTRIC**—A device by means of which the exact distance of an enemy's ship or other target can be readily determined.

**FIRE ALARM, AUTOMATIC**—(See Alarm, Fire, Automatic).

**FIRE ALARM SIGNAL BOX**—(See Box, Fire Alarm Signal)

**FIRE, HOT, ST. ELMO'S**—A term proposed by Tesla for a form of powerful brush discharge between the secondary terminals of a high frequency induction coil.

**FITTINGS OR FIXTURES, ELECTRIC LIGHT**—The sockets, holders, arms, etc., required for holding or supporting incandescent electric lamps.

**FIXTURES, TELEGRAPHIC**—A term generally limited to the variously shaped supports provided for the attachment of telegraphic wires.

**FLASHED FILAMENTS**—(See Filaments, Flashed).

**FLASHES, AURORAL**—Sudden variations in the intensity of the auroral light. Intermittent flashes of auroral light that occur during the prevalence of an aurora.

**FLASHING OF DYNAMO-ELECTRIC MACHINE**—(See Machine, Dynamo-Electric, Flashing of).

**FLATS**—A name sometimes applied to those parts of commutator segments the surface of which, through wear, has become lower than the other portions.

**FLOW, MAGNETIC**—The magnetic flux.

**FLOW OF CURRENT, ASSUMED DIRECTION OF**—(See Current, Assumed Direction of Flow of).

**FLUID, DEPOLARIZING**—An electrolytic fluid in a voltaic cell that prevents polarization.

**FLUORESCENCE**—A property possessed by certain solid or liquid substances of becoming self-luminous while exposed to light.

**FLUX, MAGNETIC**—The number of lines of magnetic force that pass or flow through a magnetic circuit. The total number of lines of magnetic force in any magnetic field.

The magnetic flux is also called the magnetic flow.

**FLYER, ELECTRIC**—A wheel arranged so as to be set into rotation by the escape of convection streams from its points when connected with a charged conductor.

**FOCUS**—A point in front or back of a lens or mirror, where all the rays of light meet or seem to meet.

**FOLLOWING HORN OF POLE PIECES OF DYNAMO-ELECTRIC MACHINE**—(See Horns, Following of Pole Pieces of a Dynamo-Electric Machine).

**FOOT-POUND**—A unit of work.

**FORCE**—Any cause which changes or tends to change the condition of rest or motion of a body.

**FORCE, CENTRIFUGAL**—The force that is supposed to urge a rotating body directly away from the center of rotation.

**FORCE, COERCIVE**—The power of resisting magnetization or demagnetization.

**FORCE, CONTACT**—A difference of electrostatic potential, produced by the contact of dissimilar metals.

**FORCE, ELECTRIC**—The force developed by electricity.

**FORCE, ELECTROMOTIVE**—The force starting electricity in motion, or tending to start electricity in motion.

The force which moves or tends to move electricity.

**FORCE, ELECTROMOTIVE, ABSOLUTE UNIT OF**—A unit of electromotive force expressed in absolute or C. G. S. units. The one-hundred millionth part of a volt, since 1 volt equals  $10^8$  C. G. S. units of electromotive force.



**FORCE, ELECTROMOTIVE, AVERAGE OR MEAN**—The sum of the values of a number of separate electromotive forces divided by their number.

**FORCE, ELECTROMOTIVE, BACK**—A term sometimes used for counter electromotive force.

Counter electromotive force is the preferable term.

**FORCE, ELECTROMOTIVE COUNTER**—An opposed or reverse electromotive force, which tends to cause a current in the opposite direction to that actually produced by the source. In an electric motor, an electromotive force contrary to that produced by the current which drives the motor, and which is proportional to the velocity attained by the motor.

**FORCE, ELECTROMOTIVE, DIRECT**—An electromotive force acting in the same direction as another electromotive force already existing.

**FORCE, ELECTROMOTIVE, EFFECTIVE**—The difference between the direct and the counter electromotive force.

**FORCE, ELECTROMOTIVE, IMPRESSED**—The electromotive force acting on any circuit to produce a current therein.

**FORCE, ELECTROMOTIVE, INVERSE**—An electromotive force which acts in the opposite direction to another electromotive force already existing.

**FORCE, ELECTROMOTIVE, OF INDUCTION**—The electromotive force developed by any inductive action.

In a coil of wire undergoing induction, the value of the induced electromotive force does not depend in any manner on the nature of the material of which the coil is composed.

FORCE, ELECTROMOTIVE, OF SECONDARY OR STORAGE CELL, TIME-FALL OF—A gradual decrease in the potential difference of a storage battery observed during the discharge of the same.

FORCE, ELECTROMOTIVE, OF SECONDARY OR STORAGE CELL, TIME-RISE OF—A gradual increase in the potential difference of a secondary or storage cell observed on beginning the discharge after a prolonged rest.

FORCE, ELECTROMOTIVE, SECONDARY IMPRESSED—An electromotive force produced which varies in such manner as to produce a simple periodic current, or an electromotive force the variations of which can be correctly represented by a simple-periodic curve.

FORCE, ELECTROMOTIVE THERMO—An electromotive force, or difference of potential, produced by differences of temperature acting at thermo-electric junctions.

FORCE, ELECTROMOTIVE VIRTUAL, OR EFFECTIVE—The square root of the mean square of an alternating or variable current.

FORCE, ELECTROSTATIC—The force producing the attractions or repulsions of charged bodies.

FORCE, ELECTROSTATIC, LINES OF—Lines of force produced in the neighborhood of a charged body by the presence of the charge.

Lines extending in the direction in which the force of electrostatic attraction or repulsion acts.

FORCE, LINES OF, CUTTING—Passing a conductor through lines of magnetic force, so as to cut to intersect them.

**FORCE LINES OF, DIRECTION OF**—It is generally agreed to consider the force lines of magnetic force as coming out of the north pole of a magnet and passing into its south pole.

**FORCE, LOOPS OF**—A term sometimes employed in the sense of lines of force.

**FORCE, MAGNETIC**—The force which causes the attractions or repulsions of magnetic poles.

**FORCE, MAGNETIC, LINES OF**—Lines extending in the direction in which the magnetic force acts.

Lines extending in the direction in which the force of magnetic attraction or repulsion acts.

**FORCE, MAGNETIC, LINES OF, CONDUCTING POWER FOR**—A term employed by Faraday for magnetic permeability.

**FORCE, MAGNETO-MOTIVE**—The force that moves or drives the lines of magnetic force through a magnetic circuit against the magnetic resistance.

**FORCE, MAGNETO-MOTIVE, PRACTICAL UNIT OF**—A value of the magneto-motive force equal to  $4\pi$  multiplied by the amperes of one turn, or to 1-10 of the absolute unit.

**FORCE, TUBES OF**—Tubes bounded by lines of electrostatic or magnetic force.

**FORCE, TWISTING**—A term sometimes used for torque.

**FORCE, UNIT OF**—A force which, acting for one second on a mass of one gramme, will give it a velocity of one centimetre per second.

Such a force of unit is called a dyne.

**FORCES, PARALLELOGRAM OF**—A parallelogram constructed about the two lines that represent the direction and intensity with which two forces are simultaneously acting on a body, in order to determine the direction and intensity of the resultant force with which it moves.

**FORK, TROLLEY**—The mechanism which mechanically connects the trolley wheel to the trolley pole.

**FORMING PLATES OF SECONDARY OR STORAGE CELLS**—(See Plates of Secondary or Storage Cells, Forming of).

**FORMULAE**—Mathematical expressions for some general rule, law or principle.

**FOUCAULT CURRENTS**—(See Currents, Foucault).

**FREE MAGNETIC POLE**—(See Pole, Magnetic, Free).

**FREQUENCY OF ALTERNATIONS**—(See Alternations, Frequency of).

**FRICTIONAL ELECTRICAL MACHINE**—(See Machine, Frictional Electric).

**FRICTIONAL ELECTRICITY**—(See Electricity, Frictional)

**FROG, GALVANOSCOPIC**—The hind legs of a recently killed frog employed as an electroscope or galvanoscope by sending an electric current from the nerves to the muscles.

**FROG, TROLLEY**—The name given to the device employed in fastening or holding together the trolley wires at any point where the trolley wire branches, and properly guiding the trolley wheel along the trolley wire on the movement of the car over the track.

**FURNACE, ELECTRIC**—A furnace in which heat generated electrically is employed for the purpose of effecting difficult fusions for the extraction of metals from their ores, or for other metallurgical operations.

**FUSE BLOCK**—(See Block, Fuse).

**FUSE BOX**—(See Box, Fuse).

**FUSE, BRANCH**—A safety fuse or strip placed in a branch circuit.

**FUSE, CONVERTER**—A safety fuse connected with the circuit of a converter or transformer.

**FUSE, ELECTRIC**—A device for electrically igniting a charge of powder.

**FUSE, MAIN**—A safety fuse or strip placed in a main circuit.

**FUSE, SAFETY**—A strip, plate or bar of lead, or some readily fusible alloy, that automatically breaks the circuit in which it is placed on the passage of a current of sufficient power to fuse such strip, plate or bar, when such current would endanger the safety of other parts of the circuit.

## G

**GAINS**—The spaces cut in the faces of telegraph poles for the support or placing of the cross arms.

**GALVANIC BATTERY**—(See Battery, Galvanic).

**GALVANIC CELL**—(See Cell, Voltaic).

**GALVANIC POLARIZATION**—(See Polarization, Galvanic).

GALVANIC TASTE—(See Taste, Galvanic).

GALVANISM—A term sometimes employed to express the effects produced by voltaic electricity.

GALVANIZATION, ELECTRO-METALLURGICAL — The process of covering any conductive surface with a metallic coating by electrolytic deposition, such, for example, as the thin copper coating deposited on the carbon pencils or electrodes used in systems of arc lighting.

GALVANOMETER—An apparatus for measuring the strength of an electric current by the deflection of a magnetic needle.

The galvanometer depends for its operation on the fact that a conductor, through which an electric current is flowing, will deflect a magnetic needle placed near it. This deflection is due to the magnetic field caused by the current.

GALVANOMETER, ABSOLUTE—A galvanometer whose constant can be calculated with an absolute calibration.

GALVANOMETER, ASTATIC—A galvanometer, the needle of which is astatic.

GALVANOMETER, BALLISTIC—A galvanometer designed to measure the strength of currents that last but a moment, such, for example, as the current caused by the discharge of a condenser.

GALVANOMETER CONSTANT—(See Constant, Galvanometer).

GALVANOMETER, DEAD-BEAT — A galvanometer, the needle of which comes quickly to rest, instead of swinging repeatedly to-and-fro. (See Damping).

**GALVANOMETER, DEPREZ-D'ARSONVAL**—A form of dead-beat galvanometer.

**GALVANOMETER, DIFFERENTIAL**—A galvanometer containing two coils so wound as to tend to deflect the needle in opposite directions.

**GALVANOMETER, FIGURE OF MERIT OF**—The reciprocal of the current required to produce a deflection of the galvanometer needle through one degree of the scale.

**GALVANOMETER, MARINE**—A galvanometer devised by Sir William Thomson for use on steamships where the motion of magnetized masses of iron would seriously disturb the needles of ordinary instruments.

**GALVANOMETER, MIRROR**—A galvanometer in which, instead of reading the deflections of the needle directly by its movements over a graduated circle, they are read by the movements of a spot of light reflected from a mirror attached to the needle.

**GALVANOMETER, REFLECTING**—A term sometimes applied to a mirror galvanometer.

**GALVANOMETER, SENSIBILITY OF**—The readiness and extent to which the needle of a galvanometer responds to the passage of an electric current through its coils.

**GALVANOMETER, SINE**—A galvanometer in which a vertical coil is movable around a vertical axis, so that it can be made to follow the magnetic needle in its deflections.

In the sine galvanometer, the coil is moved so as to follow the needle until it is parallel with the coil. Under these circumstances, the strength of the deflecting currents in any two different cases is proportional to the sines of the angles of deflection.

**GALVANOMETER, TANGENT**—An instrument in which the deflecting coil consists of a coil of wire within which is placed a needle very short in proportion to the diameter of the coil, and supported at the center of the coil.

The galvanometer acts as a tangent galvanometer only when the needle is very small as compared with the diameter of the coil. The length of the needle should be less than one-twelfth the diameter of the coil.

**GALVANOMETER, TORSION**—A galvanometer in which the strength of the deflecting current is measured by the torsion exerted on the suspension system.

**GAP, AIR**—A gap, or opening in a magnetic circuit containing air only.

**GAP, AIR, MAGNETIC**—A gap filled with air which exists in the opening at any part of a core of iron or other medium of high permeability.

**GAP, SPARK**—A gap forming part of a circuit between two opposing conductors, separated by air, or other similar dielectric which is closed by the formation of a spark only when a certain difference of potential is attained.

**GAS, DIELECTRIC, STRENGTH OF**—The strain a gas is capable of bearing without suffering disruption, or without permitting a disruptive discharge to pass through it.

**GAS-LIGHTING, MULTIPLE ELECTRIC**—A system of electric gas-lighting in which a number of gas-jets are lighted by means of a discharge of high electromotive force, derived from a Ruhmkorff coil or a static induction machine.



- GASSING—The evolution of gas from the plates of a storage or secondary cell.
- GAUGE, BATTERY—A form of portable galvanometer, suitable for ordinary test work.
- GAUGE, WIRE, AMERICAN—A name sometimes applied to the Brown & Sharpe Wire Gauge.
- GAUGE, WIRE, BIRMINGHAM—A term sometimes applied to one of the English wire gauges.
- GAUGE, WIRE, MICROMETER—A gauge employed for accurately measuring the diameter of a wire in thousandths of an inch, based on the principle of the vernier or micrometer.
- GAUSS—The unit of intensity of magnetic field.
- GAUSS, FLEMING'S—Such a strength of magnetic field as is able to develop an electromotive force of one volt in a wire one million centimetres in length moved through the field with unit velocity.
- GAUSS, S. P. THOMPSON'S—Such a strength of magnetic field that its intensity is equal to  $10^8$  C. G. S. units.
- GAUSS, SIR WILLIAM THOMSON'S—Such an intensity of magnetic field as would be produced by a current of one ampere at the distance of one centimetre.
- GENERATOR, DYNAMO-ELECTRIC—An apparatus in which electricity is produced by the mechanical movement of conductors through a magnetic field so as to cut the lines of force. A dynamo-electric machine.
- GENERATOR, MOTOR—A dynamo-electric generator in which the power required to drive the dynamo is obtained from an electric current.

**GENERATOR, PYRO-MAGNETIC**—An apparatus for producing electricity directly from heat derived from the burning of fuel.

**GERMAN SILVER ALLOY**—(See Alloy, German Silver).

**GIMBALS**—Concentric rings of brass, suspended on pivots in a compass box, and on which the compass card is supported so as to enable it to remain horizontal notwithstanding the movements of the ship.

**GLOBE, VAPOR, OF INCANDESCENT LAMP**—A glass globe surrounding the chamber of an incandescent electric lamp, for the purpose of enabling the lamp to be safely used in an explosive atmosphere, or to permit the lamp to be exposed in places where water is liable to fall on it.

**GOVERNOR, CURRENT**—A current regulator. A device for maintaining constant the current strength in any circuit.

**GOVERNOR, ELECTRIC**—A device for electrically controlling the speed of a steam engine, the direction of current in a plating bath, the speed of an electric motor, the resistance of an electric circuit, the flow of water or gas into or from a containing vessel, or for other similar purposes.

**GRAME**—A unit of weight equal to 15.43235 grains.

The grame is equal to the weight of one cubic centimetre of pure water at the temperature of its maximum density.

**GRAMOPHONE**—An apparatus for recording and reproducing articulate speech.

- GRAPHITE**—A soft variety of carbon suitable for writing on paper or similar surfaces.
- GRAY'S HARMONIC TELEGRAPHY**—(See Telegraphy, Gray's Harmonic Multiple).
- GRAVITATION**—A name applied to the force which causes masses of matter to tend to move towards one another.
- GRAVITY, CENTRE OF**—The centre of weight of a body.
- GRID**—A lead plate, provided with perforations, or other irregularities of surface, and employed in storage cells for the support of the active material. The support provided for the active material on the plate of a secondary or storage cell.
- GROTHUSS' HYPOTHESIS**—(See Hypothesis, Grothuss).
- GROUND DETECTOR**--(See Detector, Ground).
- GROUND OR EARTH**—A general term for the earth when employed as a conductor, or as a large reservoir of electricity.
- GROUND-RETURN**—A general term used to indicate the use of the ground or earth for a part of an electric circuit. The earth or ground which forms part of the return path of an electric circuit.
- GROUND-WIRE**—The wire or conductor leading to or connecting with the ground or earth in a grounded circuit.
- GUARD, FAN**—A wire netting placed around the fan of an electric motor for the purpose of preventing its revolving arms from striking external objects.
- GUTTA-PERCHA**—A resinous gum obtained from a tropical tree and valuable electrically for its high insulating powers.

GYMNOTUS ELECTRICUS—The electric eel.

## H

H.—A contraction for the horizontal intensity of the earth's magnetism.

H.—A contraction used in mathematical writings for the magnetizing force that exists at any point, or, generally, for the intensity of the magnetic force.

The letter H, when used in mathematical writings or formulae for the intensity of the magnetic force, is always represented in bold or heavy faced type, thus: **H**

HAIR, ELECTROLYTIC REMOVAL OF—The permanent removal of hair from any part of the body, by the electrolytic destruction of the hair follicles.

HALF-SHADES FOR INCANDESCENT LAMPS—Shades for incandescent electric lamps, in which one-half of the lamp chamber proper is covered with a coating of silver, or other reflecting surface for reflecting the light, or is ground for the purpose of diffusing the light.

HANDHOLE OF CONDUIT—A box or opening communicating with an underground cable, provided for readily tapping the cable, and of sufficient size to permit of the introduction of the hand.

HANGER, DOUBLE-CURVE TROLLEY—A trolley hanger generally employed at the ends of single and double curves, and on intermediate points on double track curves, supported by lateral strain in opposite directions.

HANGER, TROLLEY—A device for supporting and properly insulating trolley wires.

HARMONIC RECEIVER—(See Receiver, Harmonic).

**HARMONIC TELEGRAPH**—(See Telegraphy, Gray's Harmonic Multiple).

**HEAD LIGHT, LOCOMOTIVE, ELECTRIC**—An electric light placed in the focus of a parabolic reflector in front of a locomotive engine.

The lamp is so placed that its voltaic arc is a little out of the focus of the reflector, so that, by giving a slight divergence to the reflected light, the illumination extends a short distance on either side, of the tracks.

**HEAT**—A form of energy.

The phenomena of heat are due to a vibratory motion impressed on the molecules. Heat is transmitted through space by means of a wave motion in the universal ether. This wave motion is the same as that causing light.

A hot body loses its heat by producing a wave motion in the surrounding ether. This process is called radiation. (See Radiation).

The energy given off by a heated body cooling is called radiant energy.

**HEAT ELECTRIC**—Heat produced by means of electric current.

**HEAT, MECHANICAL EQUIVALENT OF**—The amount of mechanical energy, converted into heat, that would be required to raise the temperature of 1 pound of water 1 degree Fahr.

The mechanical equivalence between the amount of energy expended and the amount of heat produced, as measured in heat units.

Rowland's experiments, the results of which are generally accepted, gave 778 foot-pounds as the energy equivalent to that expended in raising the temperature of 1 pound of water from 39 degrees F. to 40 degrees F.

**HEAT, SPECIFIC**—The capacity of a substance for heat as compared with the capacity of an equal quantity of some other substance taken as unity.

Water is generally taken as the standard for comparison, because its capacity for heat is greater than that of any other common substance.

**HEAT UNIT**—The quantity of heat required to raise a given weight of water through a single degree.

(1.) The British Heat Unit, or Thermal Unit, or the amount of heat required to raise 1 pound of water at greatest density 1 degree Fahr. This unit represents an amount of work equal to 778 foot-pounds.

(2.) The Greater Calorie, or the amount of heat required to raise the temperature of 1,000 grammes of water 1 degree C. (See Calorie).

(3.) The Smaller Calorie, or the amount of heat required to raise the temperature 1 gramme of water 1 degree C.

(4.) The Joule, or the quantity of heat developed in one second by the passage of a current of one ampere through a resistance of one ohm.

**HEATER, ELECTRIC**—A device for the conversion of electricity into heat for purposes of artificial heating.

**HEDGEHOG TRANSFORMER**—(See Transformer, Hedgehog).

**HENRY, A**—The practical unit of self-induction.

A circuit has a self-induction of one Henry when a change of one ampere per second produces in it a counter E. M. F. of one volt.

**HIGH-BARS**--A term applied to those commutator segments, or parts of commutator segments, which, through less wear, faulty construction or looseness, are higher than adjoining portions.

**HOLDERS, CARBON, FOR ARC LAMPS**—A clutch or clamp attached to the end of the lamp rod or other support, and provided to hold the carbon pencils used on arc lamps.

**HOLDERS FOR BRUSHES OF DYNAMO-ELECTRIC MACHINE**—A device for holding the collecting brushes of a dynamo-electric machine.

**HOLTZ MACHINE**—(See Machine, Holtz).

**HOOD FOR ELECTRIC LAMP**—A hood provided for the double purpose of protecting the body of an electric lamp from rain or sun, and for throwing its light in a general downward direction.

**HORIZONTAL COMPONENT OF EARTH'S MAGNETISM**—(See Component, Horizontal, of Earth's Magnetism).

**HORNS, FOLLOWING, OF POLE PIECES OF A DYNAMO-ELECTRIC MACHINE**—The edges or terminals of the pole pieces of a dynamo-electrical machine from which the armature is carried during its rotation.

**HORNS, LEADING, OF POLE PIECES OF A DYNAMO-ELECTRIC MACHINE**—The edges or terminals of the pole pieces of a dynamo-electrical machine from which the armature is carried during its rotation.

**HORSE-POWER**--A commercial unit for power or rate of doing work.

**HORSE-POWER, ELECTRIC**—(See Power, Horse, Electric).

HORSESHOE MAGNET—(See Magnet, Horseshoe).

HOTEL ANNUNCIATOR—(See Annunciator, Hotel).

HOUR, AMPERE—A unit of electrical quantity equal to one ampere flowing for one hour.

HOUR, HORSE-POWER—A unit of work.

An amount of work equal to one-horse power for an hour.

One horse power is equal to 1,980,000 foot-pounds, or 745.941 watt hours.

HOUR, KILO-WATT—A unit of electrical power equal to a kilo-watt maintained for one hour.

HOUR, LAMP—Such a service of electric current as will maintain one electric lamp during one hour.

HOUR, WATT—A unit of electrical work.

An expenditure of electrical work of one watt for one hour.

HUMAN BODY, ELECTRICAL RESISTANCE OF—(See Body, Human, Resistance of).

HYDROGEN, ELECTROLYTIC—Hydrogen produced by electrolytic decomposition.

HYPOTHESIS, GROTHUSS—A hypothesis produced by Grothuss to account for the electrolytic phenomena that occur on closing the circuit of a voltaic cell.

HYSTERESIS—Molecular friction to magnetic change of stress.

A retardation of the magnetizing or demagnetizing effects as regards the causes which produce them.

The quality of a paramagnetic substance by virtue of which energy is dissipated on the reversal of its magnetization.



## I

**I. H. P.**—A contraction for indicated horse-power, or the horse-power of an engine as obtained by the means of an indicator card.

**IGNITION, ELECTRIC**—The ignition of a combustible material by heat of an electric origin.

**ILLUMINATION, ARTIFICIAL**—The employment of artificial sources of light.

**ILLUMINATION, UNIT OF**—A standard of illumination proposed by Preece, equal to the illumination given by a standard candle at the distance of 12.7 inches.

**IMPEDANCE**—Generally any opposition to current flow.

A quantity which is related to the strength of the impressed electromotive force of a simple periodic or alternating current, in the same manner that resistance is related to the steady electromotive force of a continuous current.

**IMPEDANCE COIL**—(See Coil, Impedance).

**IMPRESSED ELECTROMOTIVE FORCE**—(See Force, Electromotive, Impressed).

**INCANDESCENCE**—To shine or glow by means of heat.

**INCANDESCENCE, ELECTRIC**—The shining or glowing of a substance, generally a solid, by means of heat of electric origin.

**INCLINATION, ANGLE OF**—The angle which a magnetic needle, free to move in a horizontal plane, makes with a horizontal line passing through its point of support.  
The angle of magnetic dip.

INCANDESCENT ELECTRIC LAMP—(See Lamp, Electric, Incandescent).

INCLINATION, MAGNETIC—The angular deviation from a horizontal position of a freely suspended magnetic needle.

INDIA RUBBER—A resinous substance obtained from the milky juice of several tropical trees.

INDICATOR, ELECTRIC—A name applied to various devices, generally operated by the deflection of a magnetic needle, or the ringing of a bell, or both, for indicating, at some distant point, the condition of an electric circuit, the strength of current that is passing through it, the height of water or other liquid, the pressure on a boiler, the temperature, the speed of an engine or line of shafting, the working of a machine or other similar events or occurrences.

INDICATOR, ELECTRIC, FOR STEAMSHIPS—An electric indicator operated by circuits connected with the throttle valve and reversing gear of the steam engine.

INDICATOR, LAMP—An apparatus used in the central station of a system of incandescent lamp distribution to indicate the presence of the proper voltage or potential difference on the mains.

INDICATOR, POTENTIAL—An apparatus for indicating the potential difference between any points of a circuit.

INDICATOR, SPEED—A name sometimes applied to a tachometer. A revolution counter.

INDUCED CURRENT—(See Current, Induced).

**INDUCTANCE**—The induction of a current on itself, or on other circuits.

Self-induction.

A term generally employed instead of self-induction.

That property in virtue of which a finite electromotive force, acting on a circuit, does not immediately generate the full current due to its resistance, and when the electromotive force is withdrawn, time is required for the current strength to fall to zero.—(Fleming.)

A quality by virtue of which the passage of an electric current is necessarily accompanied by the absorption of electric energy in the formation of a magnetic field.

**INDUCTANCE, CO-EFFICIENT OF**—A constant quantity, such that when multiplied by the current strength passing in any coil or circuit, will represent numerically the induction through the coil or circuit due to that current.

A term sometimes used for co-efficient of self-induction.

**INDUCTANCE, VARIABLE**—The inductance which occurs in circuits formed partly or wholly of substances like iron or other paramagnetic substances, the magnetic permeability of which varies with the intensity of the magnetic induction, and where the lines of force have their circuit partly or wholly in such material or variable magnetic permeability.

**INDUCTION**—An influence exerted by a charged body or by a magnetic field on neighboring bodies without apparent communication.

**INDUCTION, ELECTRO—DYNAMIC**—Electromotive forces set up by induction in conductors which are either actually or practically moved so as to cut the lines of magnetic force.

These electromotive forces, when permitted to act through a circuit, produce an electric current.

**INDUCTION, ELECTRO-MAGNETIC**—A variety of electrodynamic induction in which electric currents are produced by the motion of electro-magnetic solenoids.

**INDUCTION, ELECTROSTATIC**—The production of an electric charge in a conductor brought into an electrostatic field.

**INDUCTION, MAGNETIC**—The production of magnetism in a magnetizable substance by bringing it into a magnetic field.

**INDUCTION, MAGNETIC, CO-EFFICIENT OF**—A term sometimes used instead of magnetic permeability. (See Permeability, Magnetic).

**INDUCTION, MAGNETIC LINES OF**—Lines which show not only the direction in which magnetic induction takes place, but also the magnitude of the induction.

This term is often loosely used for lines of force.

**INDUCTION, MAGNETIC-ELECTRIC**—A variety of electrodynamic induction in which electric currents are produced by the motion of permanent magnets, or of conductors past permanent magnets.

**INDUCTION, MUTUAL**—Induction produced by two neighboring circuits on each other by the mutual interaction of their magnetic fields.

**INDUCTION, MUTUAL, CO-EFFICIENT OF**—The quantity which represents the number of lines of force which are common to or linked in with two circuits, which are producing mutual induction on each other.

**INDUCTION, REFLECTION OF**—A term proposed by Fleming to express an action which resembles a reflection of inductive power.

**INDUCTION, SELF**—Induction produced in a circuit while changing the current therein by the induction of the current on itself.

**INDUCTION, SELF, CO-EFFICIENT OF**—The amount of cutting of magnetic lines in any circuit due to the passage of unit current.

For a given coil the co-efficient of self-induction is, according to S. P. Thompson:

(1.) Proportional to the square of the number of convolutions.

(2.) Is increased by the use of an iron core.

(3.) If the magnetic permeability is assumed as constant, the co-efficient of self-induction is numerically equal to the product of the number of lines of magnetic force due to the current, and the number of times they are enclosed by the circuit.

**INDUCTION, TOTAL MAGNETIC**—The total magnetic induction of any space is the number of lines of magnetic induction which pass through that space, where the magnetizable material is placed, together with the lines added by the magnetization of the magnetic material.

**INDUCTION, UNIPOLEAR**—A term sometimes applied to the induction that occurs when a conductor is so moved through a magnetic field as to continuously cut its lines of force.

INDUCTIONLESS RESISTANCE—(See Resistance, Inductionless.)

INDUCTIVE CAPACITY, SPECIFIC—(See Capacity, Specific Inductive.)

INDUCTIVE CIRCUIT—(See Circuit, Inductive.)

INDUCTIVE RESISTANCE—(See Resistance, Inductive.)

INDUCTOR DYNAMO—(See Dynamo, Inductor.)

INDUCTORIUM—A name sometimes applied to a Ruhmkorff induction coil.

INEQUALITY, ANNUAL, OF EARTH'S MAGNETISM—Variations in the value of the earth's magnetism during the earth's revolution depending on the position of the sun.

Annual variations in the earth's magnetism.

INERTIA—The inability of a body to change its condition of rest or motion, unless some force acts on it.

INERTIA, ELECTRIC—A term sometimes employed instead of electro-magnetic inertia.

A term employed to indicate the tendency of a current to resist its stopping or starting.

INERTIA, MAGNETIC—The inability of a magnetic core to instantly lose or acquire magnetism.

INFLUENCE, MACHINE—(See Machine, Electrostatic Induction.)

INK WRITER, TELEGRAPHIC—A device employed for recording the dots and dashes of a telegraphic message in ink on a fillet or strip of paper.

**INSTALLATION**—A term embracing the entire plant and its accessories required to perform any specified work.

The act of placing, arranging or erecting a plant or apparatus.

**INSTALLATION, ELECTRIC**—The establishment of any electric plant.

**INSULATING STOOL**—(See Stool, Insulating.)

**INSULATING TAPE**—(See Tape, Insulating.)

**INSULATION, ELECTRIC**—Non-conducting material so placed with respect to a conductor as to prevent the loss of a charge, or the leakage of a current.

**INSULATOR, DOUBLE-CUP**—An insulator consisting of two funnel-shaped cups, placed in an inverted position on the supporting pin and insulated from one another by a free air space, except near the ends, which are cemented.

**INSULATOR, FLUID**—An insulator provided with a small, internally placed, annular, cup-shaped space, filled with an insulating oil, thus increasing the insulating power of the support.

**INSULATOR, OIL**—A fluid insulator filled with oil.

**INSULATOR TELEGRAPHIC OR TELEPHONIC**—A non-conducting support of telegraphic, telephonic, electric light or other wires.

**INTENSITY, MAGNETIC**—Density of magnetic induction.

**INTENSITY OF CURRENT**—(See Current, Intensity of.)

**INTENSITY OF FIELD**—(See Field, Intensity of.)

**INTENSITY OF MAGNETIZATION**—(See Magnetization, Intensity of.)

INTENSITY, PHOTOMETRIC, UNIT OF—(The amount of light produced by a candle that consumes two grains of spermaceti wax per minute.)

INTERRUPTER, AUTOMATIC—An automatic contact breaker.

INTERRUPTER, TUNING-FORK—An interrupter in which the successive makes and breaks are produced by the vibrations of a tuning-fork or reed.

INVERSION, THERMO-ELECTRIC—An inversion of the thermo-electric electromotive force of a couple at certain temperatures.

IONS—Groups of atoms or radicals which result from the electrolytic decomposition of a molecule.

IONS, ELECTRO-NEGATIVE—The negative atoms, or groups of atoms, called radicals, into which the molecules of an electrolyte are decomposed by electrolysis.

IONS, ELECTRO-POSITIVE—The positive atoms, or groups of atoms, called radicals, into which the molecules of an electrolyte are decomposed by electrolysis.

IRON-CLAD ELECTRO-MAGNET—(See Magnet, Electro, Iron-Clad.)

IRON CORE, EFFECT OF, ON THE MAGNETIC STRENGTH OF A HOLLOW COIL OF WIRE—An increase in the number of lines of magnetic force, beyond those produced by the current itself, due to the opening out of the closed magnetic circuits in the atoms or molecules of the iron.

ISOCHRONISM—Equality of time of vibration or motion.  
A contraction proposed for Joule.



## J

JABLOCHKOFF CANDLE—(See Candle, Jablochhoff.)

JAR, LEYDEN—A condenser in the form of a jar, in which the metallic coatings are placed opposite each other on the outside and the inside of the jar respectively.

JAR, LEYDEN, CAPACITY OF—The quantity of electricity a Leyden jar will hold at a given difference of potential.

JAR, LIGHTNING—A Leyden jar, the coatings of which consist of metallic fillings.

As the discharge passes, an irregular series of sparks appear, which somewhat resemble in their shape a lightning flash. Hence the origin of the term.

JAR OF SECONDARY CELL—The containing vessel in which the plates of a single secondary cell are placed.

JAR, POROUS—A porous cell.

JAR, UNIT—A small Leyden jar sometimes employed to measure approximately the quantity of electricity passed into a Leyden battery or condenser.

JOINT, AMERICAN TWIST—A telegraphic or telephonic joint in which each of the two wires is twisted around the other.

JOINT, BRITANNIA—A telegraphic or telephonic joint in which the wires are laid side by side, bound together and subsequently soldered.

JOINT, MAGNETIC—The line of junction between two separate parts of magnetization material.

**JOINT, SLEEVE**—A junction of the ends of conducting wires obtained by passing them through tubes and then twisting and soldering.

**JOINT, TESTING OF**—Ascertaining the resistance of the insulating material around a joint in a cable.

A contraction for electrostatic capacity.

**JOULE**—The unit of electric energy or work.

1 joule equals .73732 foot-pounds.

1 joule per second equals 1 watt.

The British Association proposed to call one joule the work done by one watt in one second.

## K

**K. W.**—A contraction for kilo-watt.

**KAOLIN**—A variety of white clay sometimes employed for insulating purposes.

**KAPP LINES**—(See Lines, Kapp.)

**KARTAVERT**—A kind of insulating material resembling fiber.

**KATHION**—The electro-positive ion, atom or radical into which the molecules of an electrolyte is decomposed by electrolysis.

**KATHODAL**—Pertaining to the kathode.

**KATHODE**—The conductor or plate of an electro-decomposition cell connected with the negative terminal or electrode of a battery or other source.

**KEEPER OF MAGNET**—(See Magnet, Keeper of.)

**KERITE**—An insulating material.

**KEY, DISCHARGE**—A key employed to enable the discharge from a condenser or cable to be readily passed through a galvanometer for purposes of measurement.

**KEY, INCREMENT, OF QUADRUPLIX TELEGRAPHIC SYSTEM**—A key employed to increase the strength of the current and so operate one of the distant instruments in a quadruplex system by an increase in the strength of the current.

**KEY PLUG**—A simple form of key in which a connection is readily made or broken by the insertion of a plug of metal between two metallic plates that are thus introduced into a circuit.

**KEY, REVERSING**—A key inserted in the circuit of a galvanometer for obtaining deflections of the needle on either side of the galvanometer scale.

**KEY, REVERSING, OF QUADRUPLIX TELEGRAPHIC SYSTEM**—A key employed to reverse the direction of the current and so operate one of the distant instruments, in a quadruplex system, by a change in the direction of the current.

**KEY, SHORT-CIRCUIT**—A key which in its normal condition short circuits galvanometer.

**KEY, TELEGRAPHIC**—The key employed for sending over the line the successive makes and breaks that produce the dots and dashes of the Morse alphabet, or the deflections of the needle of the needle telegraph.

**KICKING COIL**—(See Coil, Kicking.)

**KILOAMPERE**—One thousand amperes.

**KILOGRAMME**—One thousand grammes, or 2.2046 pounds avoirdupois.

KILOWATT—One thousand watts.

KILOWATT HOUR—(See Hour, Kilowatt.)

KINETIC ENERGY—(See Energy, Kinetic.)

KINETOGRAPH—A device for the simultaneous reproduction of a distant stage and its actors under circumstances such that the actors can be heard at any distance from the theatre.

KITE, FRANKLIN'S—A kite raised in Philadelphia, Pa., in June, 1752, by means of which Franklin experimentally demonstrated the identity between lightning and electricity, and which, therefore, led to the invention of the lightning rod.

KNIFE, BREAK SWITCH—(See Switch, Knife Break.)

## L

L—A contraction for co-efficient of inductance.

L—A contraction for length.

LAG, ANGLE OF—The angle through which the axis of magnetism of the armature of a dynamo-electric machine is shifted by reason of the resistance its core offers to sudden reversals of magnetization.

LAG, ANGLE OF, OF CURRENT—An angle whose tangent is equal to the ratio of the inductive to the ohmic resistance.

An angle, the tangent of which is equal to the inductive resistance of the circuit, divided by the ohmic resistance of the circuit.

LAG, MAGNETIC—A magnetic viscosity as manifested by the sluggishness with which a magnetizing force produces its magnetizing effects in iron.

LAMINATED CORE—(See Core, Laminated.)

LAMP, ALL-NIGHT—A term sometimes applied to a double-carbon arc lamp.

LAMP, ARC, ELECTRIC—An electric lamp in which the light is produced by a voltaic arc formed between two or more carbon electrodes.

LAMP, CHAMBER OF—The glass bulb or chamber of an incandescing electric lamp in which the incandescing conductor is placed, and in which is maintained a high vacuum.

LAMP, ELECTRIC, ARC, DIFFERENTIAL—An arc lamp in which the movements of the carbons are controlled by the differential action of two magnets opposed to each other, one of whose coils is in the direct and the other in shunt circuit around the carbons.

LAMP, ELECTRIC, ARC, DOUBLE CARBON—An electric arc lamp provided with two pairs of carbon electrodes, so arranged that when one pair is consumed, the circuit is automatically completed through the other pair.

LAMP, ELECTRIC GLOW—A term employed mainly in Europe for an incandescent electric lamp.

LAMP, ELECTRIC, INCANDESCENT—An electric lamp in which the light is produced by the electric incandescence of a strip or filament of some refractory substance, generally carbon.

LAMP, ELECTRIC, INCANDESCENT, LIFE OF—The number of hours that an incandescent electric lamp, when traversed by the normal current, will continue to afford a good commercial light.

- LAMP, ELECTRIC, SAFETY—An incandescent electric lamp, with thoroughly insulated leads, employed in mines, or other similar places, where the explosive effects of readily ignitable substances are to be feared.
- LAMP, ELECTRIC, SERIES CONNECTED INCANDESCENT—An incandescent electric lamp adapted for use in series circuits.
- LAMP, ELECTRIC, INCANDESCENT, ELECTRIC FILAMENT OF—A term now generally applied to the incandescing conductor of an incandescent electric lamp, whether the same be of very small cross-section or of comparatively large cross-section.
- LAMP, PILOT—In systems for the operation of electric lamps, an incandescent lamp employed in a station to indicate the difference of potential at the dynamo terminals, by means of the intensity of its emitted light.
- LAMP ROD—(See Rod, Lamp.)
- LAMPS, BANK OF—A term applied to a number of lamps, equal to about half the load, that were formerly placed in view of the attendant in circuit with a dynamo that is to be placed in a parallel circuit with another dynamo, one of the lamps of which is also in view.
- LAMPS, CARBONING—Placing carbons in electric arc lamps.
- LAUNCH, ELECTRIC—A boat, the motive power for which is electricity, suitable for launching from a ship.
- LAW, JACOBI'S—The maximum work done by a motor is reached when the counter-electromotive force is equal to one-half of the impressed electromotive force.

**LAW, JOULE'S**—The heating power of a current is proportional to the product of the resistance and the square of the current strength.

**LAW, NATURAL**—A correct expression of the order in which the causes and effects of natural phenomena follow one another.

**LAW OF OHM, OR LAW OF CURRENT STRENGTH**—The strength of a continuous current is directly proportional to the difference of potential or electromotive force in the circuit, and inversely proportional to the resistance of the circuit. i. e., is equal to the quotient arising from dividing the electromotive force by the resistance.

**LAW, VOLTAMERIC**—The chemical action produced by electrolysis in any electrolyte is proportional to the amount of electricity which passes through the electrolyte.

**LAWS, LENZ'S**—Laws for determining the directions of currents produced by electrodynamic induction.

The direction of the currents set up by electrodynamic induction is always such as to oppose the motions by which such currents were produced.

**LAWS OF COULOMB, OR LAWS OF ELECTROSTATIC AND MAGNETIC ATTRACTIONS AND REPULSIONS.**—Laws for the force of attraction and repulsion between charged bodies or between magnet poles.

The fact that the force of electrostatic attraction or repulsion between two charges, is directly proportional to the product of the qualities of electricity of the two charges and inversely proportional to the square of the distance between them, is known as Coulomb's Law.

**LAWS OF JOULE**—Laws expressing the development of heat produced in a circuit by an electric current.

**LEAD, ANGLE OF**—The angular deviation from the normal position, which must be given to the collecting brushes on the commutator cylinder of a dynamo-electric machine, in order to avoid destructive burning.

**LEAD OF BRUSHES OF DYNAMO-ELECTRIC MACHINE**—The angular deviation from the normal position, which it is necessary to give the brushes on the commutator of a dynamo-electric machine, in order to obtain efficient action.

**LEADING HORN OF POLE PIECES OF DYNAMO-ELECTRIC MACHINE**—(See Horns, Leading, of Pole Pieces of a Dynamo-Electric Machine).

**LEADING-IN WIRES**—(See Wires, Leading-In).

**LEADS**—The conductors in any system of electric distribution.

**LEAKAGE, ELECTRIC**—The gradual dissipation of a current due to insufficient insulation.

**LEAKAGE, MAGNETIC**—A useless dissipation of the lines of magnetic force of a dynamo-electric machine, or other similar device, by their failure to pass through the armature where they are needed.

Useless dissipation of lines of magnetic force outside that portion of the field of a dynamo-electric machine through which the armature moves.

**LECLANCHE'S VOLTAIC CELL**—(See Cell, Voltaic, Leclanche).



**LEG**--In a system of telephonic exchange, where a ground return is used, a single wire, or, where a metallic circuit is employed, two wires, for connecting a subscriber with the main switchboard, by means of which any subscriber may be legged or placed directly in circuit with two or more other parties.

**LEGAL OHM**—(See Ohm, Legal).

**LENGTH OF SPARK**—(See Spark, Length of).

**LENZ'S LAW**—(See Law, Lenz's).

**LEYDEN JAR BATTERY**—(See Battery, Leyden Jar).

**LIGHT, ELECTRIC**—Light produced by the action of electric energy.

**LIGHT, MAXWELL'S, ELECTRO-MAGNETIC THEORY OF**  
—A hypothesis for the cause of light produced by Maxwell, based on the relations existing between the phenomena of light and those of electro-magnetism.

**LIGHT, SEARCH, ELECTRIC**—An electric arc light placed in a focusing lamp before a lens or mirror, so as to obtain either a parallel beam or a slightly divergent pencil of light for lighting the surrounding space for purposes of exploration.

**LIGHTER, CIGAR, ELECTRIC**—An apparatus for electrically lighting a cigar.

**LIGHTING, ARC**—Artificial illumination obtained by means of an arc light.

The term arc lighting is used in contradistinction to incandescent lighting.

**LIGHTING, ELECTRIC, CENTRAL STATION**—The lighting of a number of houses or other buildings from a single station, centrally located.

**LIGHTING, ELECTRIC GAS**—Igniting gas jets by means of electric discharges.

**LIGHTING, ELECTRIC, ISOLATED**—A system of electric lighting where a separate electric source is placed in each house or area to be lighted, as distinguished from the central station lighting, where electric sources are provided for the production of the current required for an entire neighborhood.

**LIGHTNING**—The spark or bolt that results from the disruptive discharge of a cloud to the earth, or to a neighboring cloud.

**LIGHTNING ARRESTER**—(See Arrester, Lightning).

**LIGHTNING, BACK-STROKE OF**—An electric discharge, caused by an induced charge, which occurs after the direct discharge of a lightning flash.

**LIGHTNING, CHAIN**—A variety of lightning flash in which the discharge takes a rippling path, somewhat resembling a chain.

**LIGHTNING, FORKED**—A variety of lightning flash, in which the discharge, on nearing the earth or other object, divides into two or more branches.

**LIGHTNING, GLOBULAR**—A rare form of lightning, in which a globe of fire appears, which quietly floats for a while in the air and then explodes with great violence.

**LIGHTNING, HEAT**—A variety of lightning flash in which the discharge lights up the surfaces of the neighboring clouds.

**LIGHTNING, SHEET**—A variety of lightning flash unaccompanied by any thunder audible to the observer, in which the entire surfaces of the clouds are illuminated.

- LIGHTNING, VOLCANIC**—The lightning discharges that attend most volcanic eruptions.
- LIGHTNING, ZIGZAG**—The commonest variety of lightning flashes, in which the discharge apparently assumes a forked zigzag, or even a chain-shaped path.
- LINE**--A wire or other conductor connecting any two points or stations.
- LINE, AERIAL**—An air line as distinguished from an underground conductor.
- LINE, ARTIFICIAL**—A line so made up by condensers and resistance coils as to have the same inductive effects on charging or discharging as an actual telegraph line.
- LINE, CAPACITY OF**—The ability of a line or cable to act like a condenser, and therefore like it to possess a capacity.
- LINE CIRCUIT**—(See Circuit, Line).
- LINE, NEUTRAL, OF A MAGNET**--A line joining the neutral points of a magnet or points approximately midway between the poles.
- LINE, NEUTRAL, OF COMMUTATOR CYLINDER**—A line on the commutator cylinder of a dynamo-electric machine connecting the neutral points, or the points of maximum positive and negative difference of potential.
- LINEMAN**—One who puts up and repairs line circuits and attends to the devices connected therewith.
- LINES, KAPP**—A term proposed by Mr. Gisbert Kapp for a unit of lines of magnetic force.  
One Kapp line equals 6,000 C. G. S. magnetic lines.

- LINES OF FORCE, CUTTING—(See Force, Lines of, Cutting).
- LINES OF FORCE, DIRECTION OF—(See Force, Lines of, Direction of).
- LINES OF MAGNETIC FORCE—(See Force, Magnetic, Lines of).
- LINES, OVERHEAD—A term applied to telegraph, telephone and electric light or power lines that run overhead, in contradistinction to similar lines placed underground.
- LINKS, FUSE—Strips or plates of fusible metal in the form of links, employed for safety fuses for incandescent or other circuits.
- LIQUID, ELECTROPOION—A battery liquid consisting of 1 pound of bichromate of potash dissolved in 10 pounds of water, to which  $2\frac{1}{2}$  pounds of commercial sulphuric acid has been gradually added.
- LIQUID, EXCITING, OF VOLTAIC CELL—The electrolyte or liquid in a voltaic cell, which acts on the positive plate.
- LOAD, LIQUID RESISTANCE—An artificial load for a dynamo-electric machine, consisting of a mass of liquid interposed between electrodes.
- LOCAL BATTERY—(See Battery, Local).
- LOCOMOTIVE, ELECTRIC—A railway engine whose motive power is electricity.
- LOCOMOTIVE HEAD LIGHT, ELECTRIC—(See Head Light, Locomotive).

**LODESTONE**—A name formerly applied to an ore or iron (magnetic iron ore), that naturally possesses the power of attracting pieces of iron to it.

**LOOP, ELECTRIC**—A portion of a main circuit consisting of a wire going out from one side of a break in the main circuit and returning to the other side of the break.

## M

**MACHINE, ARMSTRONG'S HYDRO-ELECTRIC**—A machine for the development of electricity by the friction of a jet of steam passing over a water surface.

**MACHINE, DYNAMO-ELECTRIC**—A machine for the conversion of mechanical energy into electrical energy, by means of magneto-electric induction.

**MACHINE, DYNAMO-ELECTRIC, ALTERNATING-CURRENT**—A dynamo-electric machine in which alternating currents are produced.

**MACHINE, DYNAMO-ELECTRIC, BI-POLAR**—A dynamo-electric machine, the armature of which rotates in a field formed by two magnet poles, as distinguished from a machine the armature of which rotates in a field formed by more than two magnet poles.

**MACHINE, DYNAMO-ELECTRIC, CLOSED-COIL**—A dynamo-electric machine, the armature coils of which are grouped in sections, communicating with successive bars of a collector, so as to be connected continuously together in a closed circuit.

**MACHINE, DYNAMO-ELECTRIC, CLOSED-COIL DRUM**—A closed-coil dynamo-electric machine, the armature core of which is drum-shaped.

MACHINE DYNAMO-ELECTRIC, CLOSED-COIL RING—A closed-coil dynamo-electric machine, the armature core of which is ring-shaped.

MACHINE, DYNAMO-ELECTRIC, COMPOUND-WOUND—Machines whose field magnets are excited by more than one circuit of coils, or by more than a single electric source.

MACHINE, DYNAMO-ELECTRIC, CONTINUOUS-CURRENT—A dynamo-electric machine, the current of which is commuted so as to flow in one and the same direction, as distinguished from an alternating dynamo.

MACHINE, DYNAMO-ELECTRIC, EFFICIENCY OF—The ratio between the electric energy or the electrical horse-power produced by a dynamo, and the mechanical energy or horse-power expended in driving the dynamo.

MACHINE, DYNAMO-ELECTRIC, FLASHING OF—A name given to long flashing sparks at the commutator, due to the short circuiting of the external circuit at the commutator, by arcing over the successive commutator insulating strips.

MACHINE, DYNAMO-ELECTRIC, MULTIPOLAR—A dynamo-electric machine, the armature of which revolves in a field formed by more than a single pair of poles.

MACHINE, DYNAMO-ELECTRIC, OPEN-COIL—A dynamo-electric machine, the armature coils of which, though connected to the successive bars of the commutator, are not connected continuously in a closed circuit.

MACHINE, DYNAMO-ELECTRIC, OPEN-COIL RING—An open-coil dynamo-electric machine, the armature core of which is ring-shaped.

**MACHINE, DYNAMO-ELECTRIC, REVERSIBILITY OF—**

The ability of a dynamo to act as a motor when traversed by an electric current.

**MACHINE, DYNAMO-ELECTRIC, SEPARATELY EXCITED—**

A dynamo-electric machine in which the field magnet coils have no connection with the armature coils, but receive their current from a separate machine or source.

**MACHINE, DYNAMO-ELECTRIC, SERIES-WOUND—**

A dynamo-electric machine, in which the field circuit and the external circuit are connected in series with the armature circuit, so that the entire armature current must pass through the field coils.

**MACHINE, DYNAMO-ELECTRIC, SHUNT-WOUND—**

A dynamo-electric machine in which the field magnet coils are placed in a shunt to the armature circuit, so that only a portion of the current generated passes through the field magnet coils, but all the difference of potential of the armature acts at the terminals of the field circuit.

**MACHINE, DYNAMO-ELECTRIC, SINGLE-MAGNET—**

A dynamo-electric machine, in which the field magnet poles are obtained by means of a single coil of insulated wire, instead of by more than a single coil.

**MACHINE, DYNAMO-ELECTRIC, SPARKING OF—**

An irregular and injurious operation of a dynamo-electric machine, attended with sparks at the collecting brushes.

**MACHINE, DYNAMO-ELECTRIC, TO SHORT CIRCUIT A**

—To put a dynamo-electric machine on a circuit of comparatively small electric resistance.

**MACHINE, ELECTROSTATIC INDUCTION**—A machine in which a small initial charge produces a greatly increased charge by its inductive action on a rapidly rotated disc of glass or other dielectric.

**MACHINE, FRICTIONAL ELECTRIC**—A machine for the development of electricity by friction.

**MACHINE, HOLTZ**—A particular form of electrostatic induction machine.

**MACHINE, INDUCTOR**—An alternating current dynamo in which the field magnet projections are all of the same polarity.

**MACHINE, MAGNETO BLASTING**—A magneto-electric machine employed for generating the current used in electric blasting.

**MACHINE, MAGNETO-ELECTRIC**—A machine in which there are no field magnet coils, the magnetic field of the machine being due to the action of permanent steel magnets.

**MACHINE, RHEOSTATIC**—A machine devised by Plante in which continuous static effects of considerable intensity are obtained by charging a number of condensers in multiple-arc and discharging them in series.

**MACHINE, TOPPLER-HOLTZ**—A modified form of Holtz machine in which the initial charge of the armatures is obtained by the friction of metallic brushes against the armatures.

**MACHINE, WIMSHURST ELECTRICAL**—A form of convection electric machine invented by Wimshurst.



**MAGNET**—A body possessing the power of attracting the unlike pole of another magnet or of repelling the like pole; or of attracting readily magnetizable bodies like iron filings to either pole. A body possessing a magnetic field.

**MAGNET, ARTIFICIAL**—A magnet produced by induction from another magnet, or from an electric current.

**MAGNET, COMPOUND**—A number of single magnets, placed parallel and with their similar poles facing one another.

**MAGNET, DAMPING**—Any magnet employed for the purpose of checking the velocity of motion of a moving body or magnet.

**MAGNET, ELECTRO**—A magnet produced by the passage of an electric current through a coil of insulated wire surrounding a core of magnetizable material.

**MAGNET, ELECTRO, HORSESHOE**—An electro-magnet, the core of which is in the shape of a horseshoe or U.

**MAGNET, ELECTRO, HUGHES'**—An electro-magnet in which a U-shaped permanent magnet is provided with pole pieces of soft iron, on which only are placed the magnetizing coils.

A quick-acting electro-magnet, in which the magnetizing coils are placed on soft iron pole pieces that are connected with and form the prolongations of the poles of a permanent horseshoe magnet.

**MAGNET, ELECTRO, IRON-CLAD**—An electro-magnet whose magnetizing coil is almost entirely surrounded by iron.

**MAGNET, HORSESHOE**—A magnetized bar of steel or iron bent in the form of a horseshoe or letter U.

**MAGNET, IRON-CLAD**—A magnet whose magnetic resistance is lowered by a casing of iron connected with the core and provided for the passage of the lines of magnetic force.

**MAGNET, KEEPER OF**—A mass of soft iron applied to the poles of a magnet through which its lines of magnetic force pass.

**MAGNET, PERMANENT**—A magnet of hardened steel or other paramagnetic substance which retains its magnetism for a long time after being magnetized.

**MAGNET, PORTATIVE POWER OF**—The lifting power of a magnet.

**MAGNET, RELAY**—An electro-magnet, whose coils are connected to the main line of a telegraphic circuit, and the movements of whose armature is employed to bring a local battery into action at the receiving station, the current of which operates the register or sounder.

**MAGNET, FIELD, OF DYNAMO-ELECTRIC MACHINE**—One of the electro-magnets employed to produce the magnetic field of a dynamo-electric machine.

**MAGNETIC ATTRACTION**—(See Attraction, Magnetic).

**MAGNETIC CIRCUIT**—(See Circuit, Magnetic).

**MAGNETIC DENSITY**—(See Density, Magnetic).

**MAGNETIC FIELD**—(See Field, Magnetic).

**MAGNETIC LEAKAGE**—(See Leakage, Magnetic).

**MAGNETIC LINES OF FORCE**—(See Force, Magnetic Lines of).

**MAGNETIC POLES**—(See Poles, Magnetic).

MAGNETIC RELUCTANCE—(See Reluctance, Magnetic).

MAGNETIC RESISTANCE—(See Resistance, Magnetic).

MAGNETIC STORM—(See Storm, Magnetic).

MAGNETIC WHIRL—(See Whirls, Magnetic).

MAGNETISM—That branch of science which treats of the nature and properties of magnets and the magnetic field.

MAGNETISM, AMPERE'S THEORY OF—A theory or hypothesis proposed by Ampere, to account for the cause of magnetism, by the presence of electric currents in the ultimate particles of matter.

MAGNETISM, ELECTRO—Magnetism produced by means of electric currents.

MAGNETISM, EWING'S THEORY OF—A theory of magnetism proposed by Prof. Ewing, based on the assumption of originally magnetized particles.

MAGNETISM, HUGHES' THEORY OF—A theory propounded by Hughes to account for the phenomena of magnetism apart from the presence of electric currents.

MAGNETISM, RESIDUAL—The magnetism remaining in the core of an electro-magnet on the opening of the magnetizing circuit.

The small amount of magnetism retained by soft iron when removed from any magnetizing field.

MAGNETISM, STRENGTH OF—A term sometimes used in the sense of intensity of magnetization.

MAGNETIZABLE—Capable of being magnetized after the manner of a paramagnetic substance like iron.

**MAGNETIZATION**—The act of calling out or of endowing with magnetic properties.

**MAGNETIZATION, INTENSITY OF**—A quantity showing the intensity of the magnetization produced in a substance. A quantity showing the intensity with which a magnetizable substance is magnetized.

**MAGNETIZATION, TIME-LAG OF**—A lag which appears to exist between the time of action of the magnetizing force and the appearance of the magnetism. The time which must elapse in the case of a given paramagnetic substance before a magnetizing force can produce magnetization.

**MAGNETIZE**—To endow with magnetic properties.

**MAGNETO-ELECTRIC BELL**—(See Bell, Magneto-Electric)

**MAGNETO-ELECTRIC BRAKE**—(See Brake, Magneto-Electric).

**MAGNETOMETER**—An apparatus for the measurement of magnetic force.

**MAGNETO-MOTIVE FORCE**—(See Force, Magneto-Motive)

**MAIN, ELECTRIC**—The principal conductor in any system of electric distribution.

**MAIN, HOUSE**—A term employed in a system of multiple incandescent lamp distribution for the conductor connecting the house service conductors with a center of distribution, or with a street main.

**MAIN, STREET**—In a system of incandescent lamp distribution the conductors extending in a system of networks through the streets from junction box to junction box, through which the current is distributed from the feeder ends, through cut-outs, to the district to be lighted, and from which service wires are taken.

**MAKE-AND-BREAK, AUTOMATIC**—A term sometimes employed for such a combination of contact points with the armature of any electro-magnet, that the circuit is automatically made and broken with great rapidity.

**MARINER'S COMPASS**—(See Compass, Azimuth).

**MATERIALS, INSULATING**—Non-conducting substances which are placed around a conductor, in order that it may either retain an electric charge, or permit the passage of an electric current through the conductor without sensible leakage.

**MATTING, INVISIBLE ELECTRIC FLOOR**—A matting or other floor covering, provided with a series of electric contacts, which are closed by the passage of a person walking over them.

**MEDIUM, ELECTRO-MAGNETIC**—Any medium in which electro-magnetic phenomena occur.

**MEG OR MEGA** (as a prefix)—1,000,000 times; as, megohm, 1,000,000 ohms; megavolt, 1,000,000 volts.

**MEGOHM**—1,000,000 ohms.

**METALLIC CIRCUIT**—(See Circuit, Magnetic).

**METALLOID**—A name formerly applied to a non-metallic body, or to a body having only some of the properties of a metal, as carbon, boron, oxygen, etc.

**METALLURGY, ELECTRO**—That branch of applied science which relates to the electrical reduction or treatment of metals. Metallurgical processes effected by the agency of electricity.

**METER, AMPERE**—(See Ampere-Meter. Ammeter).

**METER, CURRENT**—A term now applied to an electric meter or galvanometer which measures the current in amperes, as distinguished from one which measures the energy in watts.

**METER, ELECTRIC**—Any apparatus for measuring commercially the quantity of electricity that passes in a given time through any consumption circuit.

**METER, ELECTRO-CHEMICAL**—An electric meter in which the current passing is measured by the electrolytic decomposition it effects.

**METER, ELECTRO-MAGNETIC**—An electric meter in which the current passing is measured by the electromagnetic effects it produces.

**METER, ENERGY**—A term sometimes applied to a watt meter.

**METER, MILLI-AMPERE**—An ampere meter graduated to read milli-amperes.

**METER, WATT**—An instrument generally consisting of a galvanometer constructed so as to measure directly the product of the current, and the difference of potential.

**MHO**—A term proposed by Sir Wm. Thomson for the practical unit of conductivity. Such a unit of conductivity as is equal to the reciprocal of 1 ohm.

**MICA**—A mineral substance employed as an insulator.

**MICA, MOULDED**—An insulating substance consisting of finely divided mica made into a paste, with some fused insulating substance, and moulded into any desired shape.

MICRO (as a prefix)—The one-millionth; as, a microfarad, the millionth of a farad; a microvolt, the one-millionth of a volt.

MICRO-FARAD—(See Farad, Micro).

MICROPHONE—An apparatus invented by Prof. Hughes for rendering faint or distant sounds distinctly audible.

MIL—A unit of length equal to the 1-1000 of an inch, or .001 inch, used in measuring the diameter of wires.

MIL, CIRCULAR—A unit of area employed in measuring the areas of cross-sections in wires, equal to .78540 square mil. The area of a circle one mil in diameter.

MIL, SQUARE—A unit of area employed in measuring the areas of cross-sections of wires, equal to .000001 square inch. One square mil equals 1.2732 circular mil.

MILLI (as a prefix)—The one-thousandth part.

MILLI-AMPERE—The thousandth of an ampere.

MINE, ELECTRO-CONTACT—A submarine mine that is fired automatically on the completion of the current of a battery placed on the shore through the closing of floating contact points by passing vessels.

MIRROR GALVANOMETER—(See Galvanometer, Mirror).

MORSE ALPHABET—(See Alphabet, Telegraphic: Morse's)

MORSE RECORDER—(See Recorder, Morse).

MORSE SYSTEM OF TELEGRAPHY—(See Telegraphy, Morse System of).

MORSE'S TELEGRAPHIC ALPHABET—(See Alphabet, Telegraphic: Morse's).

**MOTION, SIMPLE-HARMONIC**—Motion which repeats itself at regular intervals, taking place backwards or forwards, and which may be studied by comparison with uniform motion round a circle of reference.

**MOTOGRAPH, ELECTRO**—A land speaking telephone invented by Edison whereby the friction of a platinum point against a rotating cylinder of moist chalk, is reduced by the passage of an electric current.

**MOTOR, COMPOUND-WOUND**—An electric motor whose field magnets are excited by a series and a shunt wire.

**MOTOR, ELECTRIC**—A device for transforming electric power into mechanical power.

**MOTOR, ELECTRIC, ALTERNATING-CURRENT**—An electric motor driven or operated by means of alternating currents.

**MOTOR, ELECTRIC, DIRECT-CURRENT**—An electric motor driven or operated by means of direct or continuous electric currents, as distinguished from a motor driven or operated by alternating currents.

**MOTOR, ELECTRIC, SLOW-SPEED**—An electric motor so constructed as to run with fair efficiency at slow speed.

**MOTOR, PYROMAGNETIC**—A motor driven by the attraction of magnet poles on a movable core of iron or nickel unequally heated.

**MOTOR, ROTATING-CURRENT**—An electric motor designed for use with a rotating electric current.

**MOTOR, SERIES-WOUND**—An electric motor in which the field and armature are connected in series with the external circuit as in a series dynamo.



**MOTOR, SHUNT-WOUND**—An electric motor in which the field magnet coils are placed in a shunt to the armature circuit.

**MULTIPHASE CURRENT**—(See Current, Multiphase).

**MULTIPHASE DYNAMO**—(See Dynamo, Multiphase).

**MULTIPHASE SYSTEM**—(See System, Multiphase).

**MULTIPLE-SERIES**—A multiple connection of series groups.

## N

**N.**—A contraction employed in mathematical writings for the whole number of lines of magnetic force in any magnetic circuit.

**N.**—A contraction for North Pole.

**NEEDLE, ASTATIC**—A compound magnetic needle of great sensibility, possessing little or no directive power.

An astatic needle consisting of two separate magnetic needles, rigidly connected together and placed parallel and directly over each other, with opposite poles opposed.

**NEEDLE, MAGNETIC**—A straight bar-shaped needle of magnetized steel, poised near or above its center of gravity, and free to move either in a horizontal plane only, or in a vertical plane only, or in both.

**NEEDLE, MAGNETIC, DAMPED**—A magnetic needle so placed as to quickly come to rest after it has been set in motion.

**NEEDLE, MAGNETIC, DECLINATION OF**—The angular deviation of the magnetic needle from the true geographical north. The variation of the magnetic needle.

**NEEDLE, MAGNETIC, DEFLECTION OF**—The movement of a needle out of a position of rest in the earth's magnetic field or in the field of another magnet, by the action of an electric current or another magnet.

**NEEDLE, MAGNETIC, DIPPING**—A magnetic needle suspended so as to be free to move in a vertical plane, employed to determine the angle of dip or the magnetic inclination.

**NEEDLE, MAGNETIC, DIRECTIVE TENDENCY OF**—The tendency of a magnetic needle to move so as to come to rest in the direction of the lines of the earth's magnetic field.

**NEEDLE, TELEGRAPHIC**—A needle employed in telegraphy to represent by its movements to the left or right respectively the dots and dashes of the Morse alphabet.

**NEGATIVE ELECTRODE**--(See Electrode, Negative).

**NEGATIVE ELEMENT OF A VOLTAIC CELL**—(See Element, Negative, of a Voltaic Cell).

**NEGATIVE FEEDERS**—(See Feeders, Negative).

**NEGATIVE POLE**--(See Pole, Negative).

**NEUTRAL FEEDER**—The feeder that is connected with the neutral or intermediate terminal of the dynamos in a three-wire system of distribution.

**NEUTRAL LINE OF COMMUTATOR CYLINDER**—(See Line, Neutral, of Commutator Cylinder).

**NEUTRAL POINT**—(See Point, Neutral).

**NEUTRAL POINTS OF DYNAMO-ELECTRIC MACHINE**—(See Points, Neutral, of Dynamo-Electric Machine).

**NICKEL-PLATING**--(See Plating, Nickel).

**NON-CONDUCTORS**—Substances that offer so great resistance to the passage of an electric current through their mass as to practically exclude a discharge passing through them.

## O

**OHM**—The unit of electrical resistance.

Such a resistance as would limit the flow of electricity under an electromotive force of one volt to a current of one ampere, or to one coulomb per second.

**OHM, B. A.**—A contraction for British Association ohm.

**OHM, BOARD OF TRADE**—A unit of resistance as determined by a committee of the English Board of Trade.

**OHM, BRITISH ASSOCIATION**—The British Association unit of resistance, adopted prior to 1884.

**OHM, LEGAL**—The resistance of a column of mercury 1 square millimetre in area of cross-section, and 106 centimetres in length, at the temperature of 0 degree C. or 32 degrees F.

**OHM, MEG**—One million ohms.

**OHMIC RESISTANCE**—(See Resistance, Ohmic or True).

**OHMMETER**—A commercial galvanometer, devised by Ayrton, for directly measuring by the deflection of a magnetic needle, the resistance of any part of a circuit through which a strong current of electricity is flowing.

**OHM'S LAW**—(See Law of Ohm).

**OIL INSULATOR**—(See Insulator, Oil).

**OIL TRANSFORMER**—(See Transformer, Oil).

OPEN-CIRCUIT VOLTAIC CELL—(See Cell, Voltaic, Open-Circuit).

OPEN-CIRCUITED—Put on an open circuit.

OPEN-COIL DRUM DYNAMO-ELECTRIC MACHINE—(See Machine, Dynamo-Electric, Open-Coil Drum).

OSCILLATIONS, ELECTRIC—The series of partial, intermittent discharges of which the apparent instantaneous discharge of a Leyden jar through a small resistance actually consists.

OSMOSE, ELECTRIC—A difference of liquid level between two liquids on opposite sides of a diaphragm produced by the passage of a strong electric current through the liquids between two electrodes placed therein.

## P

P. D. OR p. d.—A contraction frequently employed for difference of potential.

PACINOTTI RING--(See Ring, Pacinotti).

PAIR, ASTATIC—A term sometimes applied to an astatic couple.

PAPAFFINE—A name given to various solid hydrocarbons of the marsh gas series, that are derived from coal or petroleum by the action of nitric acid.

PARAMAGNETIC--Possessing properties ordinarily recognized as magnetic. Possessing the power of concentrating the lines of magnetic force.

PARAMAGNETISM—The magnetism of a paramagnetic substance.

**PELTIER EFFECT**—(See Effect, Peltier).

**PENDANT, ELECTRIC**—A hanging fixture provided with a socket for the support of an incandescent lamp.

**PENDANT, FLEXIBLE ELECTRIC LIGHT**—A pendant for an incandescent lamp formed by the flexible conductors which support the lamp.

**PENDULUM, ELECTRIC**—A pendulum so arranged that its to-and-fro motion send electric impulses over a line, either by making or breaking contacts.

**PERIODIC CURRENT, POWER OF**—The rate of transformation of the energy of a circuit traversed by a simple periodic current.

**PERIODICITY**—The rate of change in the alterations or pulsations of an electric current.

**PERMANENT MAGNET VOLTMETER**—(See Voltmeter, Permanent Magnet).

**PERMEABILITY CURVE**—(See Curve, Permeability).

**PERMEABILITY, MAGNETIC**—Conductibility for lines of magnetic force.

The ratio existing between the magnetization produced, and the magnetizing force producing such magnetization.

**PERMEAMETER**—An apparatus devised by S. P. Thompson for roughly measuring the magnetic permeability.

**PHASE, ANGLE OF DIFFERENCE OF, BETWEEN ALTERNATING CURRENTS OF SAME PERIOD**—The angle which measures the shifting of phase of a simple periodic current with respect to another due to lag or other cause.

- PHASE, SHIFTING OF, OF ALTERNATING CURRENT—  
A change in phase of current due to magnetic lag or other causes.
- PHONE—A term frequently used for telephone.
- PHONOGRAM—A record produced by the phonograph.
- PHONOGRAPH—An apparatus for the reproduction of articulate speech, or of sounds of any character, at any indefinite time after their occurrence, and for any number of times.
- PHOSPHORESCENCE, . ELECTRIC — Phosphorescence caused in a substance by the passage of an electric discharge.
- PHOSPHORESCENCE, PHYSICAL—Phosphorescence produced in matter by the actual impact of light waves resulting in a vibratory motion of the molecules of sufficient rapidity to cause them to emit light.
- PHOSPHORUS—ELECTRIC SMELTING OF—An electric process for the direct production of phosphorus.
- PHOTOMETER—An apparatus for measuring the intensity of the light emitted by any luminous source.
- PHOTOMETER, ACTINIC—A photometer in which the intensity of any light is measured by the amount of chemical decomposition it effects.
- PHOTOMETER, DISPERSION—A photometer in which the light to be measured is decreased in intensity a known amount so as to more readily permit it to be compared with a standard light of much smaller intensity.
- PHOTOMETER, SHADOW—A photometer in which the intensity of the light to be measured is estimated by a comparison of the distances at which it and a standard light produce a shadow of the same intensity.

**PHOTOMETER, TRANSLUCENT DISC**—A photometer in which the light to be measured is placed on one side of a partly translucent and partly opaque disc, and a standard candle is placed on the opposite side, and the intensity of the light estimated by the distances of the light from the disc when an equal illumination of all parts of the disc is obtained.

**PHOTOPHONE**—An instrument invented by Bell for the telephonic transmission of articulate speech along a ray of light instead of along a conducting wire.

**PIECES, POLE, OF DYNAMO-ELECTRIC MACHINE**—Masses of iron connected with the poles of the field magnet frames of dynamo-electric machines, and shaped to conform to the outline or contour of the armature.

**PILE, DRY**—A voltaic pile or battery consisting of numerous cells, the voltaic couple in each of which consists of sheets of paper covered with zinc-foil on one disc and black oxide of manganese on the other.

**PILE, THERMO, DIFFERENTIAL**—A thermopile in which the two opposite faces are exposed to the action of two nearly equal sources of heat in order to determine accurately the differences in thermal intensities of such sources of heat.

**PILE, THERMO-ELECTRIC**—A number of separate thermo-electric couples, united in series, so as to form a single thermo-electric source.

**PILOT LAMP**—(See Lamp, Pilot.)

**PIN, INSULATOR**—A bolt by means of which an insulator is attached to the telegraphic support or arm.

**PITH BALL**—(See Balls, Pith.)

PLANE, PROOF—A small insulated conductor employed to take test charges from the surfaces of insulated, charged conductors.

PLAT—A word sometimes used for installation, or for the apparatus required to carry on any manufacturing operation.

PLANTS, ELECTRICITY OF—Electricity produced naturally by plants during their vigorous growth.

PLATE, NEGATIVE, OF STORAGE CELL—That place of a storage cell which, by the action of the charging current, is converted into or partly covered with a coating of spongy lead.

PLATE, NEGATIVE, OF VOLTAIC CELL—The electro-negative element of a voltaic couple.  
That element of a voltaic couple which is negative in the electrolyte of the cell.

PLATE, POSITIVE, OF STORAGE BATTERY—That plate of a storage battery which is converted into, or covered by, a layer of lead peroxide, by the action of the charging current.

That plate of storage battery which is connected with the positive terminal of the charging source and which is, therefore, the positive pole of the battery on discharging.

PLATE, POSITIVE, OF VOLTAIC CELL—The electro-positive in the electrolyte of the cell.

PLATES OF SECONDARY OR STORAGE CELL, FORMING OF—Obtaining a thick coating of lead peroxide on the lead plates of a storage battery, by repeatedly sending the charging current through the cell alternately in opposite directions.



**PLATING, ELECTRO**—The process of covering any electrically conducting surface with a metal by the aid of the electric current.

**PLATING, NICKEL**—Electro-plating with nickel.

**PLATING, SILVER**—Electro-plating with silver.

**PLOW**—The sliding contacts connected to the motor of an electric street car, and placed within the slotted underground conduit, and provided for the purpose of taking off the current from the electric mains placed therein, as the contacts are pushed forward over them by the motion of the car.

**PLUG**—A piece of metal in the shape of a plug, provided for making or breaking a circuit by placing in, or removing from, a conical opening formed in the ends of two closely approached pieces of metal which are connected with the circuits to be made or broken.

**PLUG, SAFETY**—A wire, bar, plate or stripe of readily fusible metal, capable of conducting, without fusing, the current ordinarily employed on the circuit, but which fuses, and thus breaks the circuit, on the passage of an abnormal current.

**PLUG, SHORT-CIRCUITING**—A plug by means of which one part of a circuit is cut out by being short-circuited.

**PLUG, WALL**—A plug provided for the insertion of a lamp or other electro-receptive device in a wall socket, and thus connecting it with a lead.

**PLUGS, GRID**—Plugs of active material that fill the spaces or apertures in the lead grid or plate of a storage battery.

**PLUNGE BATTERY**—(See Battery, Plunge.)

**POINT, CARBON**—A term formerly applied to the carbon electrodes used in the production of the voltaic arc.

**POINTS, NEUTRAL, OF DYNAMO-ELECTRIC MACHINE**  
—Two points of greatest difference of potential, situated on the commutator cylinder, at the opposite ends of a diameter thereof, at which the collecting brushes must rest in order to carry off the current quietly.

**POLARITY, MAGNETIC**—The polarity acquired by a magnetizable substance when brought into a magnetic field.

**POLARIZATION**—A counter E. M. F. produced by the passage of a current through an electric couple or battery.

**POLARIZED ARMATURE**—See Armature, Polarized.

**POLE CHANGER**—A switch or key for changing or reversing the direction of current produced by any electric source, such as a battery.

**POLE, CONSEQUENT**—A magnet pole formed by two free north or two free south poles placed together.

**POLE, MAGNETIC, FREE**—A pole in a piece of iron, or other paramagnetic substance, which acts as if it existed as one magnetic pole only.

**POLE, MAGNETIC, NORTH**—That pole of a magnetic needle which points approximately to the earth's geographical north.

**POLE, MAGNETIC, NORTH-SEEKING**--That pole of a magnetic needle which points approximately towards the earth's geographical north.

**POLE, MAGNETIC SALIENT**—A term sometimes applied to the single poles at the extremities of an anomalous magnet in order to distinguish them from the double or consequent pole formed by the juxtaposition of two simliar magnetic poles.

**POLE, MAGNETIC, SOUTH**—That pole of a magnetic needle which points approximately towards the earth's geographical south.

The south-seeking pole of a magnetic needle.

**POLE, NEGATIVE**—That pole of an electric source through which the current is assumed to enter or flow back into the source after having passed through the circuit external to the source.

**POLE, POSITIVE**—That pole of an electric source out of which the electric current is assumed to flow.

**POLE, TELEGRAPHIC**—A wooden or iron upright on which telegraphic or other wires are hung.

**POLE, TROLLEY**—The pole which supports the trolley bearing and rests on the socket in the trolley base frame in an overhead wire electric railway system.

**POLES, MAGNETIC**—The two points where the lines of magnetic force pass from the iron into the air, and from the air into the iron.

The two points in a magnet where the magnetic force appears to be concentrated.

**POPGUN, ELECTRO-MAGNETIC**—A magnetizing coil, provided with a tubular space for the insertion of a core, much shorter than the length of the coil, which, when the energizing current is passed through the coil, is thrown violently out from the coil.

**POROUS CUP**—(See Cup, Porous.)

**POSITIVE DIRECTION OF LINES OF MAGNETIC FORCE**  
—(See Force, Magnetic, Lines of, Positive Direction of.)

**POSITIVE PLATE OF STORAGE BATTERY**—See Plate, Positive, of Storage Battery.)

**POSITIVE PLATE OF VOLTAIC CELL**—(See Plate, Positive, of Voltaic Cell.)

**POSITIVE POLE**—(See Pole, Positive).

**POST, BINDING**—A device for connecting the terminal of an electric source with the terminal of an electro-receptive device, or for connecting different parts of an electric apparatus with one another.

**POTENTIAL, ALTERNATING**—A potential, the sign of direction of which is alternately changing from positive to negative.

**POTENTIAL CONSTANT**—A potential which remains constant under all conditions.

**POTENTIAL, DIFFERENCE OF**—A term employed to denote that portion of the electromotive force which exists between any two points in a circuit.

**POTENTIAL, ELECTRIC**—The power of doing electric work.

Electrical level.

**POTENTIAL, FALL OF**—A decrease of potential in the direction in which an electric current is flowing, proportional to the resistance when the current is constant.

**POTENTIAL, MAGNETIC**—The amount of work required to bring up a unit north-seeking magnetic pole from an infinite distance to a given point in a magnetic field.

**POTENTIAL, UNIT DIFFERENCE OF**—Such a difference of potential between two points that requires the expenditure of one erg of work to bring a unit of positive electricity from one of these points to another, against the electric force. (See Erg.)

The practical unit of difference of potential is the volt.

**POTENTIOMETER**—An apparatus for the galvanometer measurement of electromotive forces, or differences of potential, by a zero method.

**POWER**—Rate of doing work.

Mechanical power is generally measured in horse power, which is equal to work done at the rate of 550 foot-pounds per second.

**POWER, CANDLE**—An intensity of light emitted from a luminous body equal to the light produced by a standard candle.

**POWER, CANDLE, NOMINAL**—A term sometimes applied to the candle-power taken in a certain favorable direction.

This term is generally used in arc lighting. In the ordinary arc lamp the greatest amount of light is emitted at a particular point, viz: from the crater in the upper or positive carbon.

**POWER, CANDLE, SPHERICAL**—The average or mean value of candle power taken at a number of points around the source of light.

**POWER, CONDUCTING, FOR ELECTRICITY**—The ability of a given length and area of cross-section of a substance to conduct electricity, as compared with an equal length and area of cross-section of some other substance, such as pure silver or copper.

**POWER, ELECTRIC**—Power developed by means of electricity.

**POWER, ELECTRIC, DISTRIBUTION OF**—The distribution of electric power by means of any suitable system of generators, connecting circuits and electric motors.

**POWER, ELECTRIC TRANSMISSION OF**—The transmission of mechanical energy by converting it into electric energy at one point or end of a line, and reconverting at some distant point from electrical to mechanical energy.

**POWER, HORSE**—A rate of doing work equal to 550 foot-pounds per second, or 33,000 foot-pounds per minute.

**POWER, HORSE, ELECTRIC**—Such a rate of doing electric work as is equal to 746 watts per second.

This rate is equivalent to 33,000 foot-pounds per minute, or 550 foot-pounds per second.

**POWER, PROJECTING, OF MAGNET**—The power a magnet possesses of throwing or projecting its lines of magnetic force across an intervening air space or gap.

**PRESSURE WIRES**—(See Wires, Pressure).

**PRIMARY COIL**—(See Coil, Primary).

**PRIMARY, THE**—That conductor in an induction coil, or transformer, which receives the impressed electromotive force, or which carries the inducing current.

**PRIME CONDUCTOR**—(See Conductor, Prime).

**PRONY BRAKE**—(See Brake, Prony).

**PULL, ELECTRIC BELL**—A circuit-closing device operated by a pull.

**PULSATING CURRENT**—(See Current, Pulsating).

**PUMP, AIR, MERCURIAL**—A device for obtaining a high vacuum by the use of mercury.

**PUMP, AIR, SPRENGEL'S MERCURIAL**—A mercurial air pump in which the vacuum is obtained by means of the fall of a stream of mercury.

**PUSH**—A name sometimes applied to a push button, or to a floor push.

**PUSH BUTTON**—(See Button, Push).

**PYRO-ELECTRICITY**—(See Electricity, Pyro).

**PYROMETER, SIEMEN'S ELECTRIC**—An apparatus for the determination of temperature by the measurement of the electric resistance of a platinum wire exposed to the heat whose temperature is to be measured.

## Q

**QUADRATURE, IN**—A term employed to express the fact that one simple periodic quantity lags 90 degrees behind another.

**QUANTITY, UNIT OF ELECTRIC**—A definite amount or quantity of electricity called the coulomb.

## R

R.—A contraction used for ohmic resistance.

**RADIATION, ELECTRO-MAGNETIC**—The sending out in all directions from a conductor, through which an oscillating discharge is passing, of electro-magnetic waves in all respects similar to those of light except that they are of much greater length.

**RAILROAD, ELECTRIC**—A railroad. or railway, the cars on which are driven or propelled by means of electric motors connected with the cars.

**RAILROADS, AUTOMATIC ELECTRIC SAFETY SYSTEM FOR**—A system for automatically preventing the approach of two trains at any speed beyond a predetermined safety from collisions of moving railroad trains by dividing the road into a number of blocks or sections of a given length, and so maintaining telegraphic communication between towers located at the ends of each of such blocks as to prevent, by the display of suitable signals, more than one train or engine from being on the same block at the same time.

**RAILROADS, ELECTRIC, CONTINUOUS OVERHEAD SYSTEM OF MOTIVE POWER FOR**—A variety of the dependent system of motive power for electric railroads in which a continuous bare conductor is connected with the terminals of a generating dynamo, and supported overhead by suitable means, and a traveling wheel or trolley is moved over the same by the motion of the car, in order to carry off the current from the line to the car motor.



**RAILROADS, ELECTRIC, CONTINUOUS SURFACE SYSTEM OF MOTIVE POWER FOR**—A variety of the dependent system of motive power for electric railroads, in which the terminals of the generating dynamo are connected to the continuous bare metallic conductor that extends along the entire track on the surface of the roadway or street, and from which the current is taken off by means of a traveling conductor connected with the moving car.

**RAILROADS, ELECTRIC, CONTINUOUS UNDERGROUND SYSTEM OF MOTIVE POWER FOR**—A variety of the dependent system of motive power for electric railways, in which a continuous bare conductor is placed underground in an open slotted conduit, and the current taken off from the same by means of sliding or rolling contacts carried on the moving car.

**RAILROADS, ELECTRIC, DOUBLE-TROLLEY SYSTEM FOR**—A system of electric railroad propulsion, in which a double trolley is employed to take the driving current from two overhead trolley wires.

**RAILROADS, ELECTRIC, INDEPENDENT SYSTEM OF MOTIVE POWER FOR**—A term for the electric propulsion of railway cars by means of primary or storage batteries placed on the car and directly connected with the motor.

**RAILROADS, ELECTRIC, SINGLE-TROLLEY SYSTEM**—A system of electric railroad propulsion in which a single trolley is employed to take the driving current from a single overhead trolley wire.

**RAY, ELECTRIC**—A species of fish named the ray, which, like the electric eel, possesses the power of producing electricity.

**RECEIVER, HARMONIC**—A receiver, employed in systems of harmonic telegraphy, consisting of an electro-magnetic reed, tuned to vibrate to one note or rate only.

**RECEIVER, PHONOGRAPHIC**—The apparatus employed in a telephone, phonograph, graphophone or gramophone for the reproduction of articulate speech.

**RECEIVER, TELEPHONIC**—The receiver employed in the telephone.

**RECORD, GRAMOPHONE**—The irregular indentations, cuttings or tracings made by a point attached to the diaphragm spoken against, and employed in connection with the receiving diaphragm for the reproduction of articulate speech.

**RECORDER, CHEMICAL, BAIN'S**—An apparatus for recording the dots and dashes of a Morse telegraphic dispatch, on a sheet of chemically prepared paper.

**RECORDER, MORSE**—An apparatus for automatically recording the dots and dashes of a Morse telegraphic dispatch, on a fillet of paper drawn under an indenting or marking point on a striking lever, connected with the armature of an electro-magnet.

**RECORDER, SIPHON**—An apparatus for recording in ink on a sheet of paper, by means of a fine glass siphon supported on a fine wire, the message received over a cable.

**RECTIFIED**—Turned in one and <sup>the</sup> same direction.

**REFLECTING GALVANOMETER**—(See Galvanometer, Reflecting).

**REGISTER, TELEGRAPHIC**—An apparatus employed at the receiving end of a telegraphic line for the purpose of obtaining a permanent record of the telegraphic dispatch.

**REGISTER, WATCHMAN'S ELECTRIC**—A device for permanently recording the time of a watchman's visit to each of the different localities he is required to visit at stated intervals.

**REGULATION, AUTOMATIC, OF DYNAMO-ELECTRIC MACHINE**—Such a regulation of a dynamo-electric machine as will automatically present constant either the current or the potential difference.

**REGULATION, HAND**—Such a regulation of a dynamo-electric machine as will preserve constant, either the current or the potential, said regulation being effected by hand as distinguished from automatic regulation.

**REGULATOR, AUTOMATIC**—A device for securing automatic regulation as distinguished from hand regulation.

**RELAY**—An electro-magnet, employed in systems of telegraphy, provided with contact points placed on a delicately supported armature, the movements of which throw a battery, called the local battery, into or out of the circuit of the receiving apparatus.

**RELAY, DIFFERENTIAL**—A telegraphic relay containing two differentially wound coils of wire on its magnet cores.

**RELAY MAGNET**—A name sometimes given to a relay.

RELAY, MICROPHONE—A device for automatically repeating a telephonic message over another wire.

RELAY, POLARIZED—A telegraphic relay provided with a permanently magnetized armature in place of the soft iron armature of the ordinary instrument.

RELUCTANCE, MAGNETIC--A term recently proposed in place of magnetic resistance to express the resistance offered by a medium to the passage through its mass of lines of magnetic force.

RELUCTANCE, MAGNETIC, UNIT OF- Such a magnetic reluctance in a closed circuit that permits unit magnetic flux to traverse it under the action of unit magneto-motive force.

REPEATERS, TELEGRAPHIC--Telegraphic devices whereby the relay, sounder or registering apparatus, on the opening and closing of another circuit, with which it is suitably connected, is caused to repeat the signals received.

REPULSION, ELECTRO-DYNAMIC—The mutual repulsion between two electric circuits whose currents are flowing in opposite directions.

REPULSION, ELECTRO-MAGNETIC—The mutual repulsion produced by two similar electro-magnetic poles.

REPULSION, ELECTROSTATIC--The mutual repulsion produced by two similar electric charges.

REPULSION, MAGNETIC—The mutual repulsion exerted between two similar magnetic poles.

RESIDUAL MAGNETISM—(See Magnetism, Residual).

**RESIN**—A general term applied to a variety of dried juices of vegetable origin.

**RESISTANCE**—Something placed in a circuit for the purpose of opposing the passage or flow of the current in the circuit or branches of the circuit in which it is placed.

The electrical resistance of a conductor is that quality of the conductor in virtue of which there is a fixed numerical ratio between the potential difference of the two opposing faces of a cubic unit of such conductor, and the quantity of electricity which traverses either face per second, assuming a steady flow to take place normal to these faces, and to be uniformly distributed over them, such flow taking place solely by an electromotive force outside the volume considered.

**RESISTANCE, ABSOLUTE UNIT OF**—The one thousand millionth of an ohm.

**RESISTANCE BOX**—(See Box, Resistance).

**RESISTANCE COIL**—(See Coil, Resistance).

**RESISTANCE, EFFECT OF HEAT ON ELECTRIC**—Nearly all metallic conductors have their electric resistance increased by an increase of temperature.

The carbon conductor of an incandescent electric lamp, on the contrary, has its resistance decreased when raised to electric incandescence. The decrease amounts to about three-eighths of its resistance when cold.

**RESISTANCE, ELECTRIC**—The ratio between the electromotive force of a circuit and the current that passes therein. The reciprocal of electrical conductivity.

**RESISTANCE, ELECTRIC, OF LIQUIDS**—The resistance offered by a liquid mass to the passage of an electric current.

As a rule the electric resistances of liquids, with the single exception of mercury, are enormously higher than those of metallic bodies.

**RESISTANCE, FALSE**—A resistance arising from a counter electromotive force, and not directly from the dimensions of the circuit, or from its specific resistance.

**RESISTANCE, INDUCTIVE**—A resistance which possesses self-induction.

**RESISTANCE, INSULATION**—The resistance of a line or conductor existing between the line or conductor and the earth through the insulators, or between the two wires of a cable through the insulating material separating them.

**RESISTANCE, MAGNETIC**—The reciprocal of magnetic permeability or conductivity for lines of magnetic force. Resistance offered by a medium to the passage of the lines of magnetic force through it.

**RESISTANCE, NON-INDUCTIVE**—A resistance in which self-induction is practically absent.

**RESISTANCE, OHMIC**—The true resistance of a conductor due to its dimensions and specific conducting power, as distinguished from the spurious resistance produced by a counter electromotive force.

**RESISTANCE, OR CELL, SELENIUM**—A mass of crystalline selenium, the resistance of which is reduced by placing it in the form of narrow strips between the edges of broad conducting plates of brass.

RESISTANCE, SECONDARY—A term sometimes used in place of external secondary resistance.

RESISTANCE, SPECIFIC—The particular resistance which a substance offers to the passage of electricity through it.

RESISTANCE, UNIT OF—Such a resistance that unit difference of potential is required to cause a current of unit strength to pass. (See Ohm).

RESONANCE, ELECTRIC—The setting up of electric pulses in open-circuited conductors, by the action of pulses in neighboring conductors.

RESONATOR, ELECTRIC—An apparatus employed by Hertz in his investigations on electric resonance.

RESULTANT—In mechanics, a single force that represents in direction and intensity the effects of two or more separate forces.

RETARDATION—A decrease in the speed of telegraphic signaling caused either by the induction of the line conductor on itself, or by mutual induction between it and neighboring conductors, or by condenser action, or by all.

REVERSIBILITY OF DYNAMO—The ability of a dynamo to operate as a motor when traversed by an electric current.

REVERSING KEY—(See Key, Reversing).

RHEOSTAT—An adjustable resistance.

A rheostat enables the current to be brought to a standard, i. e., to a fixed value, by adjusting the resistance; hence the name.

**RHEOSTAT, WATER**—A rheostat the resistance of which is obtained by means of a mass of water of fixed dimensions.

**RING PACINNOTTI**—A kind of grame ring containing spaces or grooves for wire bobbins formed in the iron of the ring.

**ROCKER, BRUSH**—In a dynamo-electric machine or electric motor. any device for shifting the position of the brushes on the commutator cylinder.

**ROD, CLUTCH**—A clutch or clamp provided in an arc lamp to seize the lamp rod and thus arrest its fall, during feeding, beyond a certain point.

**ROD, LAMP**—A metallic rod provided in electric arc lamps for holding the carbon electrodes.

**ROD, LIGHTNING**—A rod, or wire cable of good conducting material, placed on the outside of a house or other structure, in order to protect it from the effects of a lightning discharge.

**ROD, LIGHTNING, POINTS ON**—Points of inoxidizable material, placed on lightning rods, to effect the quiet discharge of a cloud by convection streams.

**ROSETTE**—An ornamental plate provided with contacts connected to the terminals of the service wires, and placed in a wall for the ready attachment of the incandescent lamp.

A word sometimes used in place of rose.

**ROTARY-PHASE CURRENT**—(See Current, Rotating).

**ROTATING CURRENT**—(See Current, Rotating).

**RUHMKORFF COIL**—(See Coil, Rhumkorff).



**S**

S.—A contraction employed for second.

**SATURATION, MAGNETIC**—The maximum magnetization which can be imparted to a magnetic substance.

The condition of iron, or other paramagnetic substance, when its intensity of magnetization is so great that it fails to be further sensibly magnetized by any magnetic force, however great.

**SCALE, THERMOMETER, CENTIGRADE**—A thermometer scale, in which the length of the thermometric tube between the melting point of ice and the boiling point of water is divided into one hundred equal parts or degrees.

**SCALE, THERMOMETER, FAHRENHEIT'S**—A thermometer scale in which the length of the thermometer tube between the melting point of ice and the boiling point of water is divided into 180 equal parts called degrees.

**SCREEN, MAGNETIC**—A hollow box whose sides are made of thick iron, placed around a magnet or other body so as to cut it off or screen it from any magnetic field external to the box.

**SCREENING, MAGNETIC**—Preventing magnetic induction from taking place by interposing a metallic plate, or a closed circuit of insulated wire, between the body producing the magnetic field and the body to be magnetically screened.

**SECOND, WATT**—A unit of electrical work.

**SECONDARY BATTERY**—(See Battery, Secondary).

SECONDARY COIL—(See Coil, Secondary).

SECONDARY, MOVABLE—The secondary conductor of an induction coil, which, instead of being fixed as in most coils, is movable.

SECTION, TROLLEY—A single continuous length of trolley wire, with or without its branches.

SEISMOGRAPH, MICRO—An electric apparatus for photographically registering the vibrations of the earth produced by earthquakes or other causes.

SELENIUM—A comparatively rare element generally found associated with sulphur.

SELENIUM CELL—(See Cell, Selenium).

SELF-INDUCTION—(See Induction, Self).

SEMAPHORE—A variety of signal apparatus employed in railroad block systems.

SEPARATOR—An insulating sheet of ebonite, or other similar substance, corrugated and perforated so as to conform to the outline of the plates of a storage battery, and placed between them at suitable intervals, in such a manner as to avoid short-circuiting, without impeding the free circulation of the liquid.

SERIES, CONTACT—A series of metals arranged in such an order that each becomes positively electrified by contact with the one that follows it.

SERIES DISTRIBUTION OF ELECTRICITY BY CONSTANT CURRENTS—(See Electricity, Series Distribution of, by Constant Current Circuit).

**SERIES, THERMO-ELECTRIC**—A list of metals so arranged according to their thermo-electric powers, that each metal in the series is electro-positive to any metal lower in the list.

**SERIES TURNS OF DYNAMO-ELECTRIC MACHINE**—(See Turns, Series, of Dynamo-Electric Machine).

**SERIES WINDING**—(See Winding, Series).

**SERIES-WOUND DYNAMO**—(See Dynamo, Series).

**SHELLAC**—A resinous substance possessing valuable insulating properties, which is exuded from the roots and branches of certain tropical plants.

**SHOCK, ELECTRIC**—The physiological shock produced in an animal by an electric discharge.

**SHORT-CIRCUIT**—To establish a short circuit.

**SHUNT**—An additional path established for the passage of an electric current or discharge.

**SHUNT**—To establish an additional path for the passage of an electric current or discharge.

**SHUNT CIRCUIT**—(See Circuit, Shunt).

**SHUNT DYNAMO-ELECTRIC MACHINE**—(See Machine, Dynamo-Electric, Shunt-Wound).

**SHUNT, GALVANOMETER**—A shunt placed around a sensitive galvanometer for the purpose of protecting it from the effects of a strong current, or for altering its sensibility.

**SHUNT, MAGNETIC**—An additional path of magnetic material provided in a magnetic circuit for the passage of the lines of force.

- SHUTTLE ARMATURE—(See Armature, Shuttle.)
- SILVER PLATING—(See Plating, Silver.)
- SIPHON, ELECTRIC—A siphon in which the stoppage of flow, due to the gradual accumulation of air, is prevented by electrical means.
- SMELTING, ELECTRO—The separation or reduction of metallic substances from their ores by means of electric currents.
- SNAP SWITCH—(See Switch, Snap.)
- SOCKET, ELECTRIC LAMP—A support for the reception of an incandescent electric lamp.
- SOCKET, WALL—A socket placed in a wall and provided with openings for the insertion of a wall plug with which the ends of a flexible twin-lead are connected.
- SOLENOID—A cylindrical coil of wire the convolutions of which are circular.  
An electro-magnetic helix.
- SOLENOID CORE—The core, usually of soft iron, placed within a solenoid and magnetized by the magnetic field of the current passing through the solenoid.
- SOLUTION, BATTERY—The exciting liquid for voltaic cells. (See Cell, Voltaic.)
- SOURCE, ELECTRIC—Any arrangement capable of maintaining a difference of potential or an electromotive force.
- SPARK COIL—(See Coil, Spark.)
- SPARK, GAP—(See Gap, Spark.)

**SPARKING, LINE OF LEAST**—The line on a commutator cylinder of a dynamo connecting the points of contact of the collecting brushes where the sparking is a minimum.

**SPARKING OF DYNAMO-ELECTRIC MACHINE**—(See Machine, Dynamo-Electric, Sparking of.)

**SPECIFIC INDUCTIVE CAPACITY**—(See Capacity, Specific.)

**SPHERICAL ARMATURE**—(See Armature, Spherical.)

**SPIDER, ARMATURE**—A light framework or skeleton consisting of a central sleeve or hub keyed to the armature shaft, and provided with a number of radial spokes or arms for fixing or holding the armature core to the dynamo-electric machine.

**SPRING-JACK**—A device for readily inserting a loop in a main electric circuit. The spring-jack is generally used in connection with a multiple switch board.

**STAGGERING**—A term sometimes applied to the position of the brushes on a commutator cylinder, in which one brush is placed slightly in advance of the other brush so as to bridge over a break.

**STANDARD, DYNAMO**—The supports for the bearings of a dynamo-electric machine.

**STATION, CENTRAL**—A station, centrally located, from which electricity for light or power is distributed by a series of conductors radiating therefrom.

**STATION, TRANSFORMING**—In a system of distribution by transformers or converters a station where a number of transformers are placed, in order to supply a group of houses in the neighborhood.

STOOL, INSULATING—A support isolated from the ground usually by glass insulators.

STORAGE BATTERY—(See Battery, Storage.)

STORAGE CELL—(See Cell, Storage.)

STORM, ELECTRIC—An unusual condition of the atmosphere as regards the quantity of its free electricity.

STORM, MAGNETIC—Irregularities occurring in the distribution of the earth's magnetism, affecting the magnetic declination, dip, and intensity.

STRENGTH, FIELD—The intensity or total flux of magnetism of a dynamo.

STRIPPING--Dissolving the metal coating from a silver-plated or other metal-plated article.

SUBMARINE CABLE—(See Cable, Submarine.)

SUBWAY, ELECTRIC—An accessible underground way or passage provided for the reception of electric wires or cables.

SULPHATING--A name applied to one of the sources of loss in the operation of a storage battery, by means of the formation of a coating of inert sulphate of lead on the battery plates.

SUSCEPTIBILITY, MAGNETIC—The ratio existing between the induced magnetization and the magnetic force producing such magnetism. or the intensity of magnetism divided by the magnetic force.

SUSPENSION, BIFILAR—The suspension of a needle by two parallel wires or fibres, as distinguished from a suspension by a single wire or fibre.

**SUSPENSION, KNIFE-EDGE**—The suspension of a needle on knife edges that are supported on steel or agate planes.

**SWITCH BOARD**—(See Board, Switch.)

**SWITCH, BREAK-DOWN**—A special switch, employed in small three-wire systems, for connecting the positive and negative bus-wires in such a manner as to practically convert it into a two-wire system and permit the system to be supplied with current from a single dynamo.

**SWITCH, CHANGING**—A switch designed to throw a circuit from one electric source to another.

**SWITCH, DOUBLE-BREAK KNIFE**—A knife switch provided with double-break contacts.

**SWITCH, DOUBLE-POLE**—A switch that makes or breaks contact with both poles of the circuit in which it is placed.

A switch consisting of a combination of two separate switches, one connected to the positive lead and the other to the negative lead.

**SWITCH, FEEDER**—The switch employed for connecting or disconnecting each conductor of a feeder from the bus-bars in a central station.

**SWITCH, KNIFE**—A switch which is opened or closed by the motion of a knife contact which moves between parallel contact plates.

A knife-edge switch.

**SWITCH, REVERSING**—A switch for reversing the direction of a circuit.

SWITCH, SNAP—A switch in which the transfer of the contact points from one position to another is accomplished by means of a quick motion obtained by the operation of a spring.

SWITCH, TELEPHONE, AUTOMATIC—A device for automatically transferring the connection of the main line from the call bell to the telephone circuit.

SWITCH, THREE-POINT—A switch by means of which a circuit can be completed through three different contact points.

SWITCH, TIME—An automatic switch in which a predetermined time is required either to insert a resistance in or remove it from a circuit.

SWITCH, TWO-POINT—A switch by means of which a circuit can be completed through two different contact points.

SYSTEM, THREE-WIRE—A system of electric distribution for lamps or other translating devices connected in multiple, in which three wires are used instead of the two usually employed.

In the three-wire system two dynamos are generally employed, which are connected with one another in series.

## T

T.—A symbol used for time.

TACHOMETER—An apparatus for indicating at any moment on a revolving dial the exact number of revolutions per minute of a shaft or machine.



**TALK, CROSS**—In telephony an indistinctness in the speech transmitted over any circuit, due to this circuit receiving, either by accidental contacts or by induction, the speech transmitted over neighboring circuits.

**TANNING, ELECTRIC**—An application of electric currents to tanning leather.

**TAPE, INSULATING**—A ribbon of flexible material impregnated with kerite, okonite, rubber or other suitable insulating material, employed for insulating wires or electric conductors at joints, or other exposed places.

**TASTE, GALVANIC**—A sensation of taste produced when a voltaic current is passed through the tongue or in the neighborhood of the gustatory nerves, or nerves of taste.

**TEASER, ELECTRIC CURRENT**—A coil of fine wire placed on the field magnets of a dynamo-electric machine, next to the series coil wound thereon, and connected as a shunt across the main circuit.

This term is also used to designate the auxiliary winding used for producing the polyphase current in a monocyclic dynamo.

**TECHNICS, ELECTRO**—The science which treats of the physical applications of electricity and the general principles applying thereto.

**TELEGRAPHIC**—Pertaining to telegraphy.

**TELEGRAPHIC ALPHABET**—(See Alphabet, Telegraphic.)

**TELEGRAPHIC CABLE**—(See Table, Telegraphic.)

**TELEGRAPHIC CODE**—(See Code, Telegraphic.)

TELEGRAPHIC KEY—(See Key, Telegraphic.)

TELEGRAPHING—Sending a communication by means of telegraphy.

TELEGRAPHY, ACOUSTIC—A non-recording system of telegraphic communication, in which the dots and dashes of the Morse system, or the deflections of the needle in the needle systems, are replaced by sounds that follow one another at intervals, that represent the dots and dashes, or the deflections of the needle, and thereby the letters of the alphabet.

TELEGRAPHY AND TELEPHONY, SIMULTANEOUS, OVER A SINGLE WIRE—Any system for simultaneous transmission of telegraphic and telephonic messages over a single wire.

TELEGRAPHY, AUTOMATIC—A system by means of which a telegraphic message is automatically transmitted by the motion of a previously perforated fillet of paper containing perforations of the shape and order required to form the message to be transmitted.

TELEGRAPHY, CHEMICAL—A system by means of which the closings of the mainline-circuit, corresponding to the dots and dashes of the Morse alphabet, are recorded on a fillet of paper by the electrolytic action of the current on a chemical substance with which the paper fillet is impregnated.

TELEGRAPHY, DIPLEX—A method of simultaneously sending two messages in the same direction over a single wire.

Diplex telegraphy is to be distinguished from duplex telegraphy, where two messages are simultaneously transmitted over a single wire in opposite directions,

**TELEGRAPHY, DUPLEX, BRIDGE METHOD OF**—A system whereby two telegraphic messages can be simultaneously transmitted over a single wire in opposite directions.

**TELEGRAPHY, DUPLEX, DIFFERENTIAL METHOD OF**—A system of duplex telegraphy in which the coils of the receiving and transmitting instruments are differentially wound.

**TELEGRAPHY, FAC-SIMILE**—A system whereby a facsimile or copy of a chart, diagram, picture or signature is telegraphically transmitted from one station to another.

**TELEGRAPHY, FIRE ALARM**—A system of telegraphy by means of which alarms can be sent to a central station, or to the fire engine houses in the district, from call boxes placed on the line.

**TELEGRAPHY, GRAY'S HARMONIC MULTIPLE**—A system for the simultaneous transmission of a number of separate and distinct musical notes over a single wire, which separate tones are utilized for the simultaneous transmission of an equal number of telegraphic messages.

**TELEGRAPHY, INDUCTION**—A system of telegraphing by induction between moving trains and fixed stations on a railroad, by means of impulses transmitted by induction between the car and a wire parallel with the track.

**TELEGRAPHY, INDUCTION, CURRENT SYSTEM OF**—A system of induction telegraphy depending on current induction between a fixed circuit along the road, and a parallel circuit on the moving train.

TELEGRAPHY, INDUCTION, STATIC SYSTEM OF—A system of inductive telegraphy depending on the static induction between the sending and receiving instrument.

TELEGRAPHY, MORSE SYSTEM OF—A system of telegraphy in which makes and breaks occurring at intervals corresponding to the dots and dashes of the Morse alphabet are received by an electro-magnetic sounder or receiver.

TELEGRAPHY, MULTIPLEX—A system of telegraphy for the simultaneous transmission of more than four separate messages over a single wire.

TELEGRAPHY, PRINTING—A system of telegraphy in which the messages received are printed on a paper fillet.

TELEGRAPHY, QUADRUPLEX—A system for the simultaneous transmission of four messages over a single wire, two in one direction and the remaining two in the opposite direction.

TELEGRAPHY, QUADRUPLEX, BRIDGE METHOD OF—A system of quadruplex telegraphy by means of a double bridge duplex system.

TELEGRAPHY, QUADRUPLEX, DIFFERENTIAL METHOD OF—A system of quadruplex telegraphy by means of a double differential duplex system.

TELEGRAPHY, SIMPLEX—A system of telegraphy in which in a single message only can be sent over the line.

**TELEGRAPHY, STEP-BY-STEP**—A system of telegraphy in which the signals are registered by the movements of a needle over a dial on which the letters of the alphabet, etc., are marked.

**TELEGRAPHY, SUBMARINE**—A system of telegraphy in which the line wire consists of a submarine cable.

**TELEGRAPHY, SYNCHRONOUS-MULTIPLY, DELANY'S SYSTEM**—A system devised by Delany for the simultaneous telegraphic transmission of a number of messages either all in the same direction, or part in one direction and the remainder in the opposite direction.

**TELEGRAPHY, WRITING**—A species of fac-simile telegraphy, by means of which the motions of a pen attached to a transmitting instrument so vary the resistance on two lines connected with a receiving instrument as to cause the current received thereby to reproduce the motions, on a pen or stylus, which transfers them to a sheet of paper.

A system of writing telegraphy consists essentially of transmitting and receiving instruments connected by a double line wire.

**TELEPHONE**—An apparatus for the electric transmission of articulate speech.

**TELEPHONIC EXCHANGE**—(See Exchange. Telephonic, System of).

**TERMINALS**—A name sometimes applied to the poles of a battery or other electric source, or to the ends of the conductors or wires connected thereto.

**THERAPEUTICS, ELECTRO, OR ELECTRO-THERAPY**—The application of electricity to the curing of disease.

- THERMO-ELECTRIC BATTERY**—(See Battery, Thermo-Electric.)
- THERMO-ELECTRIC COUPLE**—(See Couple, Thermo-Electric.)
- THERMOMETER, ELECTRIC RESISTANCE**—A thermometer the action of which is based on the change in the electric resistance of metallic substances with changes in temperature.
- THERMOSTAT**—An instrument for automatically maintaining a given temperature by the closing of an electric circuit through the expansion of a solid or liquid.
- THERMOSTAT, MERCURIAL**—A thermostat operating by the expansion of a mercury column.
- THREE-WIRE SYSTEM**—(See System, Three-Wire.)
- TICKER SERVICE, STOCK**—The simultaneous transmission of stock quotations or other desired information to a number of subscribers.
- TIPS, POLAR**—The free ends of the field magnet pole pieces of a dynamo-electric machine.
- TORQUE**—That moment of the force applied to a dynamo or other machine which turns it or causes its rotation.  
The mechanical rotary or turning force which acts on the armature of a dynamo-electric machine or motor and causes it to rotate.
- TOUCH, DOUBLE**—A method of magnetization in which two closely approximated magnet poles are simultaneously drawn from one end of the bar to be magnetized to the other and back again, and this repeated a number of times.

**TRACTION, MAGNETIC**—The force with which a magnet holds on to or retains its armature, when once attached thereto.

**TRAMWAY, ELECTRIC**—A railway over which cars are driven by means of electricity.

An electric railroad.

**TRANSFORMER**—An inverted Ruhmkorff induction coil employed in systems of distribution by means of alternating currents.

An apparatus for raising or lowering the voltage of an electric current used in transmitting and distributing power.

A transformer is sometimes called a converter. The word transformer is, however, the one most employed.

**TRANSFORMER, CLOSED IRON CIRCUIT**—A transformer the core of which forms a complete magnetic circuit.

These transformers are sometimes called ironclad transformers.

**TRANSFORMER, CONSTANT-CURRENT**—A transformer in which a current of a constant potential in the primary is converted into a current of constant strength in the secondary, despite changes in the load on the secondary.

**TRANSFORMER, CORE**—A transformer in which the primary and secondary wires are wrapped around the outside of a core consisting of a bundle of soft iron wires or plates.

**TRANSFORMER, EFFICIENCY OF**—The ratio between the whole energy supplied in any given time to the primary circuit of a transformer and that which appears in the form of electric current in the secondary circuit.

**TRANSFORMER, HEDGEHOG**—A name applied to a particular form of open-iron circuit transformer,

**TRANSFORMER, MULTIPLE**--Any form of transformer which is connected in multiple to the primary circuit.

**TRANSFORMER, OIL**--A transformer which is immersed in oil in order to insure a high insulation.

**TRANSFORMER, ROTARY-CURRENT**--A transformer operated by means of a rotary current.

**TRANSFORMER, SHELL**--A transformer in which the primary and secondary coils are laid on each other, and the iron core is then wound through and over them so as to enclose all the copper of the primary and secondary circuits within the iron.

**TRANSFORMER, STEP-DOWN**--A transformer in which a small current of comparatively great difference of potential is converted into a large current of comparatively small difference of potential.

**TRANSFORMER, WELDING**--A transformer suitable for changing a small electric current of comparatively high difference of potential, into the heavy currents of low difference of potential required for welding purposes.

Welding transformers have in general a very low resistance in their secondary coils, and almost invariably consist of a single turn or at the most of a few turns of very stout wire.

**TRANSLATING DEVICE**--(See Device, Translating.)

**TRANSMITTER, CARBON, FOR TELEPHONES**--A telephone transmitter consisting of a button of compressible carbon.

The sound waves impart to-and-fro movements to the transmitting diaphragm, and this to the carbon button, thus varying its resistance by pressure. This button is placed in circuit with the battery and induction coil.



**TRANSMITTER, ELECTRIC**—A name applied to various electric apparatus employed in telegraphy or telephony to transmit or send the electric impulses over a line wire or conductor.

**TREATMENT, HYDRO-CARBON, OF CARBONS**—Exposing carbons, while electrically heated to incandescence, to the action of a carbonizing gas, vapor or liquid, for the purpose of rendering them more uniformly electrically conducting throughout.

**TRIMMING**—A term sometimes applied to the act of placing the carbons in an electric arc lamp.

**TROLLEY**—A rolling contact wheel that moves over the overhead lines provided for a line of electric railway cars, and carries off the current required to drive the motor car.

**TROLLEY, DOUBLE**—The traveling conductors, which move more over the lines of wire in any system of electric railways that employs two overhead conductors.

**TROLLEY POLE**—(See Pole, Trolley).

**TUBE, CROOKES'**—A tube containing a high vacuum and adapted for showing any of the phenomena of the ultra-gaseous state of matter.

**TUBES, VACUUM**—Glass tubes, from which the air has been partially exhausted and through which electric discharges are passed for the production of luminous effects.

**TURN, AMPERE**—A single turn or winding in a coil of wire through which one ampere passes.

**TURNS, SERIES, OF DYNAMO-ELECTRIC MACHINES—**

The ampere-turns in the series circuit of a compound-wound dynamo-electric machine.

**TURNS, SHUNT, OF DYNAMO-ELECTRIC MACHINE—**

The ampere-turns in the shunt circuit of a compound-wound dynamo-electric machine.

**U**

**UNITS, ABSOLUTE—**A system of units based on the centimetre for the unit of length, the gramme for the unit of mass, and the second for the unit of time.

**UNITS, CENTIMETRE-GRAMME-SECOND—**A system of units in which the centimetre is adopted for the unit of length, the gramme for the unit of mass, and the second for unit of time.

**UNITS, C. G. S.—**The centimetre-gramme-second units.

**UNITS, FUNDAMENTAL—**The units of length, time and mass, to which all other quantities can be referred.

**UNITS, HEAT—**Units based on the quantity of heat required to raise a given weight or quantity of a substance, generally water, one degree.

The principal heat units are the English heat unit, the greater and smaller calorie and the joule. (See Calorie. Joule.)

**UNITS, MAGNETIC—**Units based on the force exerted between two magnet poles.

Unit strength of a magnetic pole is such a magnetic strength of pole that repels another magnetic pole of equal strength placed at unit distance with unit force, or with the force of one dyne.

UNITS, PRACTICAL—Multiples or fractions of the absolute or centimetre-gramme-second units.

## V

V—A contraction sometimes used for volt.

V—A contraction sometimes used for velocity.

VACUUM, HIGH—A space from which nearly all traces of air or residual gas have been removed.

Such a vacuum that the length of the mean free path of the molecules of the residual atmosphere is equal to or exceeds the dimensions of the containing vessel.

VACUUM, TORRICELLIAN—The vacuum which exists above the surface of the mercury in a barometer tube or other vessel over thirty inches in vertical height.

VARIATION, MAGNETIC—Variations in the value of the magnetic declination, or inclination, that occur simultaneously over all the parts of the earth.

VARNISH, ELECTRIC—An insulating material dissolved in a solvent.

When the varnish is dry it should produce a layer or film of insulating material.

VIBRATION OR WAVE, AMPLITUDE OF—The ratio that exists in a wave between the degree of condensation and rarefaction of the medium in which the wave is propagated.

VIBRATION, PERIOD OF—The time occupied in executing one complete vibration or motion to-and-fro.

VIBRATIONS, ISOCHRONOUS--Vibrations which perform their to-and-fro motions on either side of the position of rest in equal times.

**VIBRATIONS, SYMPATHETIC**—Vibrations set up in bodies by waves of exactly the same wave rate as those produced by the vibrating body.

**VIS-VIVA**—The energy stored in a moving body, and therefore the measure of the amount of work that must be performed in order to bring a moving body to rest.

**VOLT**—The practical unit of electro-motive force.

Such an electromotive force as would cause a current ductor which cuts lines of magnetic force at the rate of 100,000,000 per sec.

Such a electromotive force as would cause a current of one ampere to flow against the resistance of one ohm.

**VOLT-AMMETER**--A wattmeter.

A variety of galvanometer capable of directly measuring the product of the difference of potential and the amperes.

**VOLT AMPERE**—A watt.

**VOLTAGE**—This term is now very commonly used for either the electromotive force or difference of potential of any part of a circuit as determined by the reading of a voltmeter placed in that part of the circuit.

**VOLTAIC ARC**—(See Arc, Voltaic.)

**VOLTAIC BATTERY**—(See Battery, Voltaic.)

**VOLTAIC CELL**—(See Cell, Voltaic.)

**VOLTAIC ELEMENT**—(See Element, Voltaic.)

**VOLTAMETER**—An electrolytic cell employed for measuring the quantity of the electric current passing through it by the amount of chemical decomposition effected in a given time.

**VOLTAMETER, COPPER**—A voltameter in which the quantity of the current passing is determined by the weight of copper deposited.

**VOLTAMETER, VOLUME**—A voltameter in which the quantity of the current passing is determined by the volume of the gases evolved.

**VOLTMETER**—An instrument used for measuring difference of potential.

**VOLTMETER, CARDEW'S**—A form of voltmeter in which the potential difference is measured by the amount of expansion caused by the heat of a current passing through a fixed resistance.

**VOLTMETER, CLOSED-CIRCUIT**—A voltmeter in which the points of the circuit, between which the potential difference is to be measured, are connected with a closed coil or circuit, and which gives indications by means of the current so produced in said circuit.

**VOLTMETER, GRAVITY**—A form of voltmeter in which the potential difference is measured by the movement of a magnetic needle against the pull of a weight.

**VOLTMETER, MAGNETIC-VANE**—A voltmeter in which the potential difference is measured by the repulsion exerted between a fixed and a moveable vane of soft iron placed within the field of the magnetizing coil.

**VOLTMETER, MULTI-CELLULAR ELECTROSTATIC**—An electrostatic voltmeter in which a series of fixed and movable plates are used instead of the single pair employed in the quadrant electrometer.

**VOLTMETER, OPEN-CIRCUIT**—A voltmeter in which the points of the circuit where potential difference is to be measured are connected with an open circuit and give indications by means of the charges so produced.

**VOLTMETER, PERMANENT MAGNET**—A form of voltmeter in which the difference of potential is measured by the movement of a magnetic needle under the combined action of a coil and a permanent magnet, against the pull of a spring.

**VULCABESTON**—An insulating substance composed of asbestos and rubber.

**VULCANITE**—A variety of vulcanized rubber extensively used in the construction of electric apparatus.

Vulcanite is sometimes called ebonite from its black color. It is also sometimes called hard rubber.

## W

**W**—A contraction sometimes used for watt.

**WALL SOCKET**—(See Socket, Wall.)

**WATCHES, DEMAGNETIZATION OF**—Processes for removing magnetism from watches.

**WATT**—The unit of electric power. The volt-ampere.

The power developed when 44.25 foot-pounds of work are done per minute, or 0.7375 foot-pounds per second.

The 1-746 of a horse-power.

**WATT-HOUR**—A unit of electric work.

A term employed to indicate the expenditure of an electrical power of one watt, for an hour.

**WATT-HOUR, KILO**—The Board of Trade unit of work equal to an output of one kilo-watt for one hour.

**WATT, KILO**—One thousand watts.

A unit of power sometimes used in stating the output of a dynamo.

**WATT-METER**—A galvanometer by means of which the simultaneous measurement of the difference of potential and the current passing is rendered possible.

The watt-meter consists of two coils of insulated wire, one coarse and the other fine, placed at right angles to each other as in the ohm-meter, only, instead of the currents acting on a suspended magnetic needle, they act on each other as in the electro-dynamometer.

**WAVE**—A disturbance in an elastic medium that is periodic both in space and time.

**WAVE, ELECTRIC**—An electric disturbance in an elastic medium that is periodic both in space and time.

**WAVES, ELECTRO-MAGNETIC**—Waves in the ether that are given off from a circuit through which an oscillating discharge is passing, or from a magnetic circuit undergoing variations in magnetic intensity.

**WELDING, ELECTRIC**—Effecting the welding union of metals by means of heat of electric origin.

In the process of Elihu Thompson, the metals are heated to electric incandescence by currents obtained from transformers, and are subsequently pressed or hammered together.

**WHEEL, TROLLEY**—A metallic wheel connected with the trolley pole and moved over the trolley wire on the motion of the car over the tracks, for the purpose of taking the current from the trolley wire by means of rolling contact therewith.

**WHIRL, ELECTRIC**—A term employed to indicate the circular direction of the lines of magnetic force surrounding a conductor conveying an elastic current.

**WHIRL, MAGNETIC**—The lines of magnetic force which surround the circuit of the conductor conveying an electric current.

**WINDING, AMPERE**—A single winding or turn through which one ampere passes.

Ampere-winding is used in the same signification as ampere-turn.

**WINDING, COMPOUND, OF DYNAMO-ELECTRIC MACHINE**—A method of winding in which shunt and series coils are placed on the field magnets.

**WINDING, SERIES**—A winding of a dynamo-electric machine in which a single set of magnetizing coils are placed on the field magnets, and connected in series with the armature and the external circuit.

**WIRE, DEAD, OF ARMATURE**—That part of the wire on the armature of a dynamo which produces no electromotive force or resultant current.

**WIRE, DUPLEX**—An insulated conductor containing two separate parallel wires.

**WIRE, FEEDING**—A term sometimes applied to the wire or lead of a multiple circuit which feeds the main.

In a system of electric railroads the feeding wires feed the trolley wires.

**WIRE, FUSE**—A readily fusible wire employed in a safety catch to open the circuit when the current is excessive.



**WIRE, HOUSE**—In a system of incandescent electric lighting any conductor that is connected with a service conductor and leads to the meter in the house.

**WIRE, INSULATED**—Wire covered with any insulating material.

**WIRE, LINE**—In telegraphy the wire that connects the different stations with one another.

**WIRE, NEGATIVE**—A term sometimes applied to that wire of a parallel circuit which is connected to the negative pole of a source.

**WIRE, NEUTRAL**—The middle wire of a three-wire system of electric distribution.

**WIRE, POSITIVE**—The wire or conductor connected to the positive pole or terminal of any electric source.

**WIRE, SLIDE**—A wire of uniform diameter employed in Wheatstone's electric bridge for the proportionate arms of the bridge.

**WIRE, SPAN**—The wire employed in systems of electric railways for holding the trolley wire in place.

**WIRE, TROLLEY**—The wire over which the trolley passes in a system of electric railways, and from which the current is taken to drive the motors on the cars.

**WIRES, DEAD**—Disused and abandoned electric wires.

**WIRES, LEADING-IN**—The wires or conductors which lead the current through (into and out of) an electric lamp.

**WIRES, PILOT**—In a system of incandescent lighting, where a comparatively low potential is employed on the mains, thin wires leading directly from the generating station to different parts of the mains, in order to determine the differences of potential at such points.

**WIRES, PRESSURE**—In a system of incandescent electric lighting, wires or conductors, series-connected with the junction boxes, and employed in connection with suitable voltmeters, to indicate the pressure at the junction boxes.

The pressure wires are sometimes called the pilot wires.

**WIRING**—Collectively the wires or conducting circuits used in any system of electric distribution.

**WORK**—The product of the force by the distance through which the force acts.

A force whose intensity is equal to one pound acting through the distance of one foot, does an amount of work equal to one foot-pound.

**WORK, ELECTRIC**—The joule. (See Joule).

1 joule equals 1 watt for 1 second.

**WORK, ELECTRIC, UNIT OF**—The volt-coulomb or joule. The product of the volts by the coulombs.

**WORKING, PARALLEL, OF DYNAMO-ELECTRIC MACHINES**—The operation of working several dynamo-electric machines as a single source, by connecting them with one another in parallel or multiple arc.

## Y

**YOKE FIELD**—That part of the field magnet frame connecting two magnet cores.

**YOKE, MULTIPLE-BRUSH**—A term sometimes applied to multiple brush rocker of a dynamo or motor.

**Z**

**ZINC, AMALGAMATION OF**—The covering or amalgamation of zinc with a layer of mercury.

**ZINC, CROW-FOOT**—A crow-foot-shaped zinc used in the gravity voltaic cell.

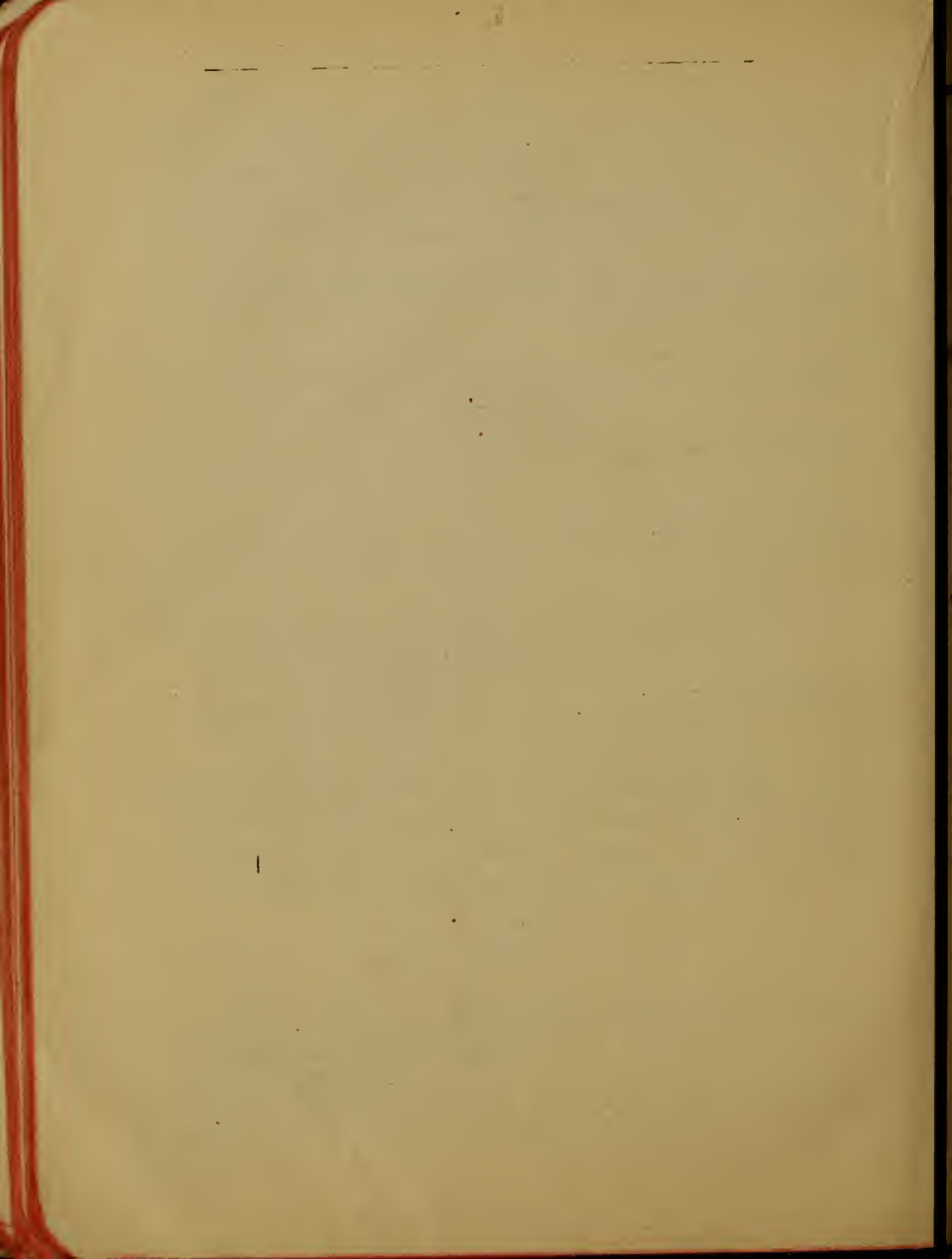

## INDEX TO TABLES.

I. Properties of Copper Wire .....	13-14
II. Currents Allowed in Wires by Fire Underwriters.	16
III. Electro-chemical Series of the Elements.....	26
IV. Data of Common Batteries .....	30
V. Properties of Metals .....	34
VI. Permeability Table .....	57
VII. Magnetic Traction or Pull.....	83
VIII. Magnetic Circuits of Dynamos.....	91
IX. Hysteresis in Soft Iron.....	131
X. Dynamo and Motor Windings.....	165-167
XI. Tensile Strength of Copper Wire.....	273
XII. Circumferences of Circles .....	274
XIII. Areas of Circles .....	275-276
XIV. Areas of Small Circles.....	277
XV. Price List Copper Magnet Wire.....	278
XVI. Specific Gravities of Metals.....	279
XVII. Decimal Equivalent of Parts of an Inch.....	280
XVIII. Wire Gauges in Mils.....	281

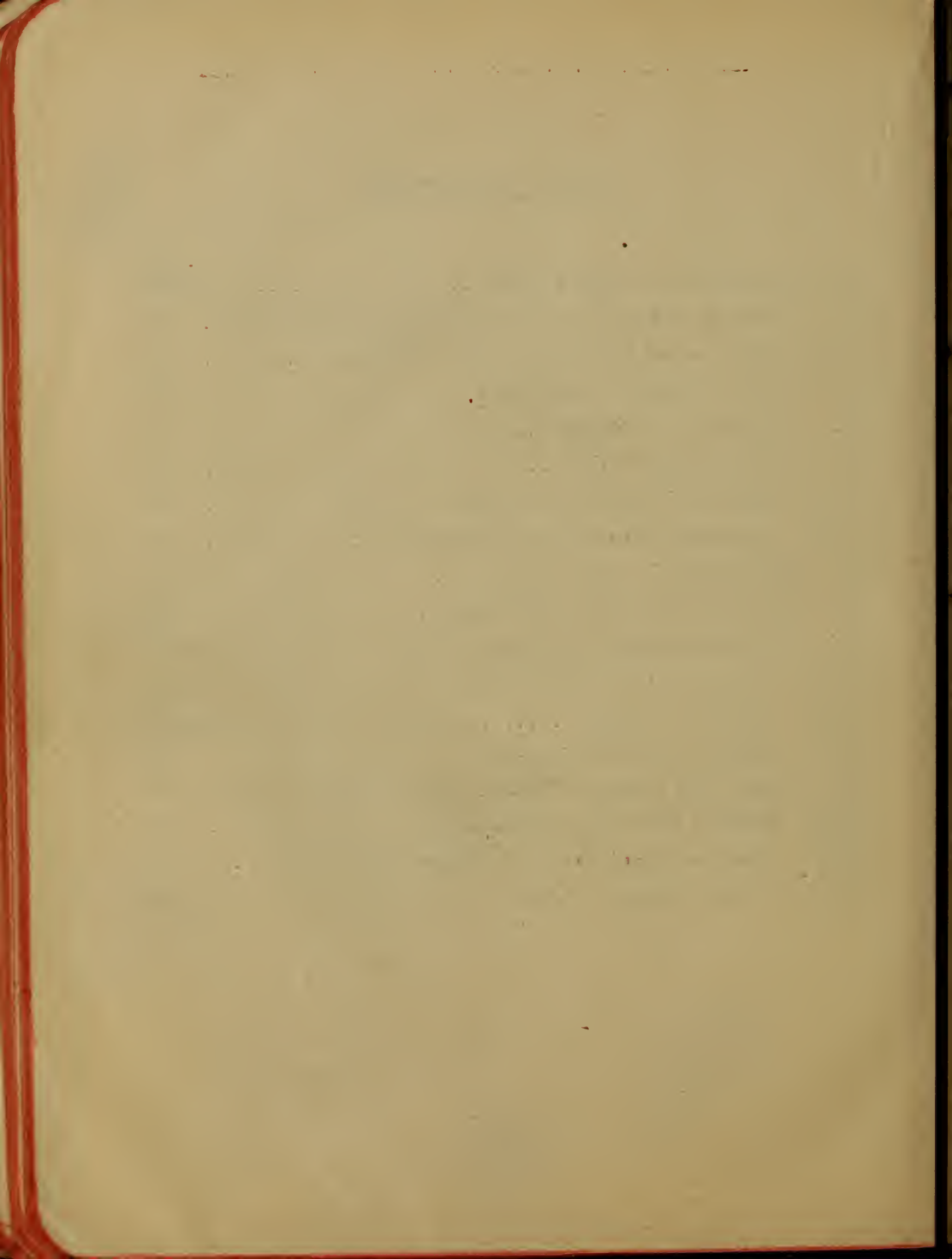

## INDEX.

### A

Alternating currents .....	219
Alternating current, advantages of.....	225
Alternations .....	219
Amalgamation of battery zincs.....	29
Ampere turns required in parts of magnetic circuit..	64
Ampere turns, calculation of from table.....	67
Ampere turns, size of wire to produce certain.....	105
Analogy between water and electricity.....	1
Anode .....	31
Armature current, division of at brushes.....	137
Armature, drum .....	116
Armature, gramme ring .....	112
Armature, iron clad .....	66
Armature reaction .....	138
Armature reaction, magnetization of fields by.....	139
Armature, smooth core .....	65
Armature, tunnel wound .....	50
Arc lamps. ....	203
Automatic rheostat .....	182

### B

Battery for experimental purposes.....	29
Battery, storage .....	35
Battery, storage capacity of.....	36
Battery, storage uses of.....	36

Batteries, table of data of.....	30
Brakes, electric .....	86
Brush arc dynamo .....	139
Brush arc motor .....	127
Brushes, inertia of .....	190
Brushes, position of in multipolar motors.....	162
Brushes, sparking affected by position of.....	146

## C

Calculation of ampere turns from table.....	72
Carbon brush .....	148
Carbon as positive element in battery cell.....	28
Capacity of storage batteries .....	35
Cathode .....	31
Circuits, primary .....	227
Circuits, secondary .....	227
Commutation, conditions of perfect .....	146-149
Commutator, vibration of .....	190
Compass, mariner's .....	40
Compound winding .....	170
Compound winding, number of series turns.....	171
Connections of armature and field magnets.....	177
Constant potential system .....	20
Constant voltage, effect on life of lamps.....	202
Copper wire, change of resistance with temperature..	106
Counter E. M. F., identity with primary.....	123
Current, three-phase .....	224
Current, two-phase .....	222
Cycle .....	219
Cycle, per second .....	221



## D

Direction of flow of current.....	31
Drop allowed in street railway feeders.....	18
Drum armature .....	116
Drum armature, winding of .....	159

## E

Earth as magnet .....	40
Eddy currents .....	133
Edison current meter .....	31
Edison dynamo, leakage co-efficient of.....	90
Electric brakes .....	86
Electro-magnet .....	43
Electropeon fluid for batteries .....	29
Electro-plating .....	32
E. M. F., counter.....	123
E. M. F., production of in armatures.....	112
E. M. F., winding for different.....	117
Enclosed arc lamps .....	203
Energy formulae .....	95
Energy in electric circuits.....	95

## F

Feeders for street railway work.....	18
Field coil, improper connection of.....	196
Field coil, heating of.....	196
Field coil, open circuit in.....	194
Field coil, short circuit in.....	195
Field discharge .....	178
Field, distortion of by armature reaction.....	141

Field magnets .....	175
Flow of current, direction of.....	31
Force, field of .....	41
Force, field of, strength in the U. S.....	41
Force, lines of .....	41
Force, mechanical, exerted on wire carrying current in magnetic field .....	49
Friction between brush and commutator.....	192

## G

Galvani his discovery .....	25
Gramme ring armature .....	112
Gramme ring, practical advantage of.....	116
Grounds .....	192
Grounds, partial .....	193
Grounds, permanent .....	193

## H

Heating of commutator .....	192
Heating of field coils .....	196
Heating of magnet coils.....	108
Helix .....	14
High voltage, use in transmission of power.....	99
Horse power, electrical, equivalent of.....	95
Horizontal winding .....	160
Hysterisis .....	130
Hysterisis in four-pole field.....	132

## I

Incandescent lamps, life of .....	10
Iron clad armature .....	66

## L

Lap winding .....	162
Leads, armature .....	160
Leakage of magnetic lines .....	89
Lentz law .....	119
Life of incandescent lamps .....	10
Lines of force .....	41

## M

Magnet, electro .....	43
Magnet, field of .....	45
Magnet, best design for lifting purposes .....	84
Magnet coils, calculation of .....	106
Magnet coils, heating of .....	124
Magnetic lines, bunching of .....	69
Magnetic traction .....	82
Magnetic lines, leakage of .....	89
Magnetic spectrum .....	42
Magnetic whirl .....	42
Magnetic vane volt meter .....	214
Magnetism .....	40
Magnetism, residual .....	213-175
Magnetization of fields by armature reaction.....	139
Mariner's compass .....	40
Mechanical force exerted in wire carrying current in magnetic field .....	49
Meter, Brush .....	213
Meter, Thompson's recording .....	215
Meter, Westinghouse .....	214
Meter, Western Electric .....	212
Meter, Weston .....	211

Motor, Baxter .....	127
Motor, Brush .....	127
Motors, compound wound .....	170
Motor, series and properties of .....	125
Motor, shunt wound, speed of .....	124
Motors .....	208-211
Multipolar field, effect of on armature reaction.....	140

## N

Nitrate of soda as electrolyte .....	28
Number of bars in commutator .....	164
Number of slots in armature .....	164
Noise of machine in operation .....	197

## O

Ohms law .....	3
Open circuits .....	186
Open circuits in field coils .....	194
Over commutation .....	147

## P

Periodicity .....	221
Permeability .....	56
Plating electro .....	32
Platinum sponge .....	27
Platinum wire in incandescent lamps .....	202
Polarization .....	26
Porous cup .....	27
Poly phase currents from direct current commutators	224
Position of brushes in multipolar machines.....	162

Power from primary batteries .....	28
Primary circuits .....	227

## R

Residual magnetism .....	175
Resistance of brush contact .....	147
Resistance of copper wire, change of with temperature	106
Resistance of copper wire, rule for .....	20
Revolving pole .....	224
Rheostat .....	177
Rhumkorf coil .....	228

## S

Saturation of magnetic circuit .....	56
Secondary circuits .....	227
Self induction .....	145
Series arc lamps .....	205
Series system of arc lighting .....	20
Series wound motor, properties of ....	125
Short circuits .....	187
Shunt motor proper, connection of .....	181
Shunt wound motor, constant speed of .....	124
Sine wave .....	221
Smee battery .....	27
Smooth core armature .....	65
Solenoid .....	45
Solenoid meter .....	216
Solid pole pieces, eddy currents in.....	134
Sparkling .....	144-189
Spectrum magnetic .....	42
Starting box, automatic .....	182

Starting box, overload .....	183
Steel ingots handled by means of magnet .....	86
Storage batteries .....	35

## T

Thompson recording meter .....	215
Three-phase current .....	226
Transformers. ....	227
Transmission of power by alternating currents .....	228
Traction magnetic .....	82
Transmission of power, connection with high voltage. 98-99	
Transmission of power, weight of copper.....	99
Tungsten steel .....	210-40
Tunnel wound armature .....	50
Two phase current .....	224

## V

Vacuum .....	201
Vertical winding .....	160
Voltage constant, effect on life of incandescent lamps	202
Voltage of storage battery .....	4
Volta's battery .....	25
Voltmeter .....	31
Volt-meter, Weston .....	207

## W

Watts, mechanical equivalent of.....	95
Watts, radiated from armature.....	106
Watts, radiated from field coil.....	107
Watts required for incandescent lamps.....	203

Wave sine .....	221
Wave winding .....	161
Weston meters .....	207-208
Windings, armature .....	165
Winding lap .....	162
Wire winding, armature, arrangement of.....	158
Wire on dynamo, office of .....	157
Wiring for equal drop .....	17
Wood arc dynamo .....	139

LB D '05



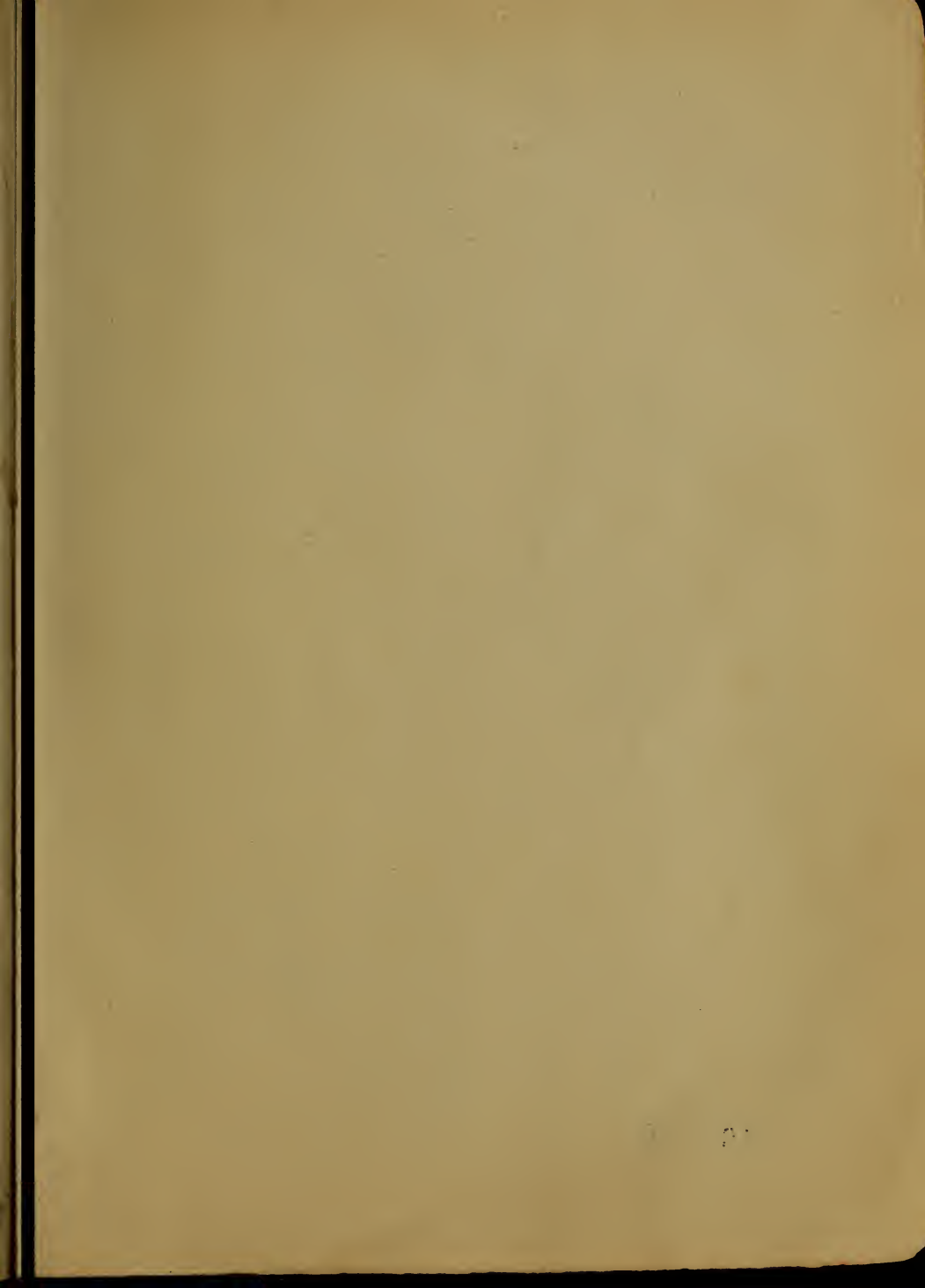

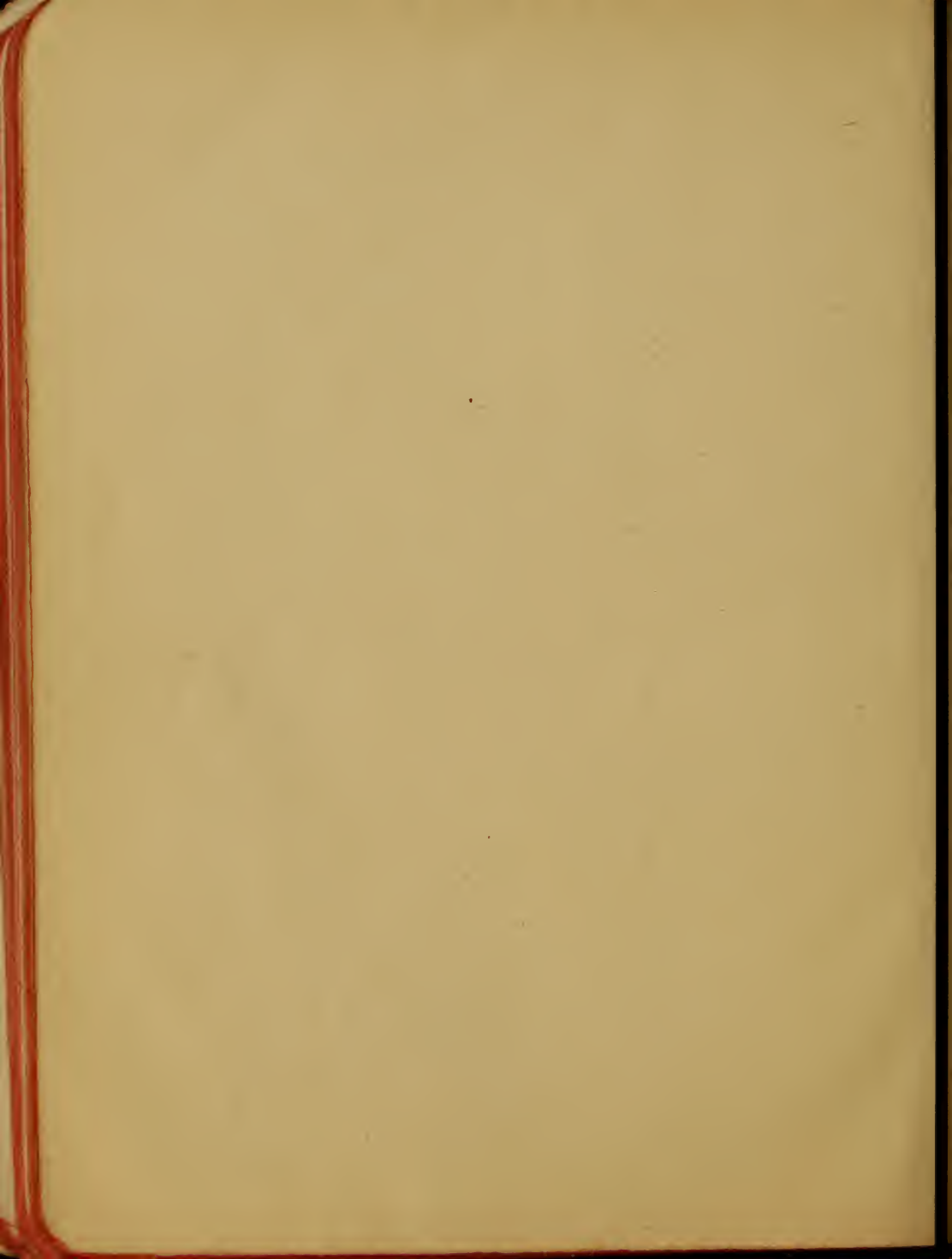

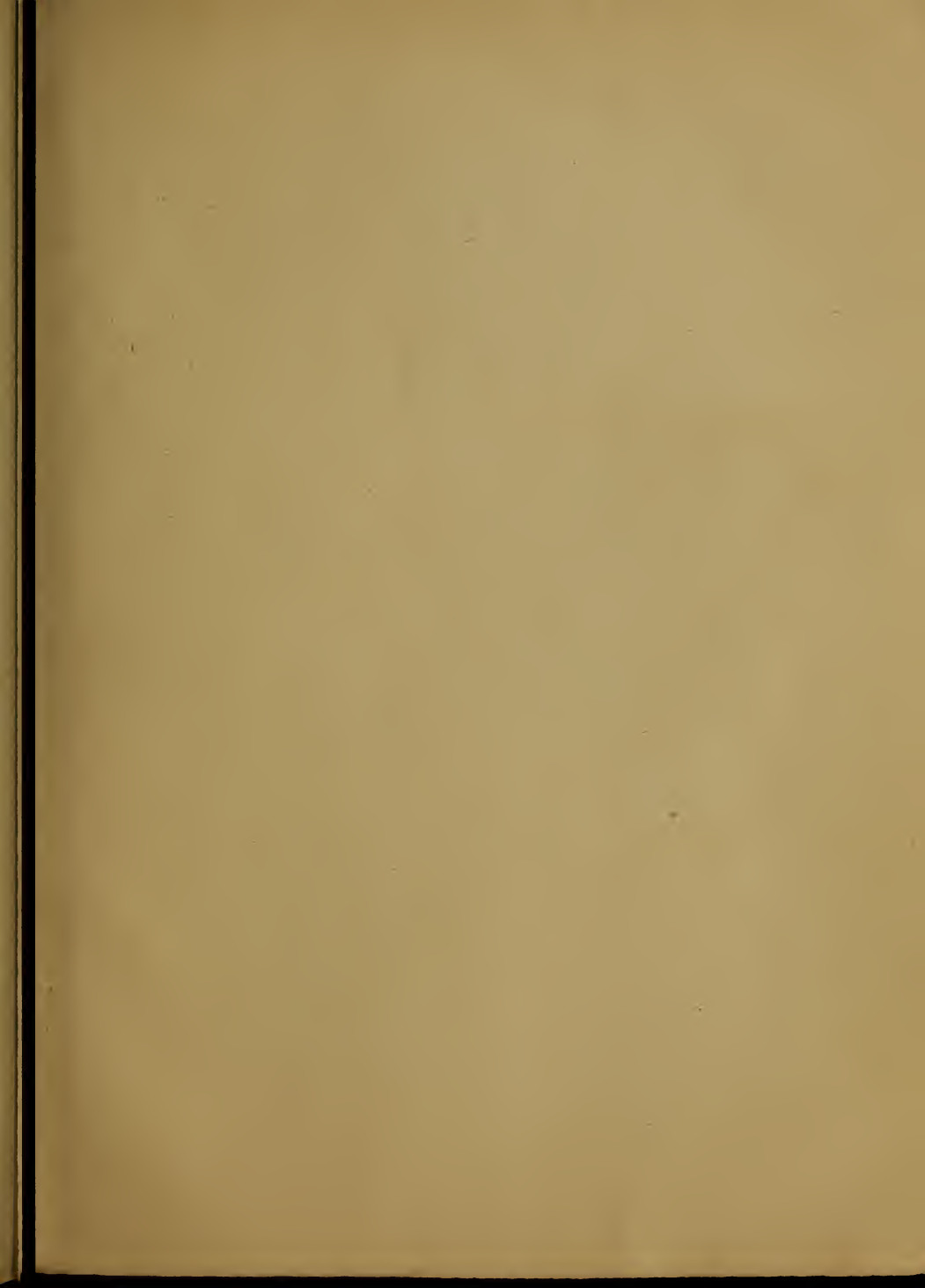

LIBRARY OF CONGRESS



0 020 237 556 A